



DP8160G

60A DC-DC Intelligent dPOL

Bel Power Solutions **DP8160G** is a second generation intelligent, fully programmable multi-phase step-down point-of-load DC-DC converter integrating digital power conversion and intelligent power management. It works with the DM7300 Series Digital Power Managers (DPM) which provides for synchronizing all system Power-On-Load regulators, for an elegant, flexible, low noise power system solution.

All key parameters, sequencing, tracking, fault protection, and compensation parameters of the DP8160G are all programmable via Bel Power Solutions I²C based GUI. All settings can be changed by a user at any time during product development and service. Once programmed, the DPM remembers all settings and configures the DP8160G through a self-clocking single wire communication bus.

FLASH memory in the DPM allows changes to be made without the need to solder or rewire the regulator.



Key Features & Benefits

- Wide input voltage range: 8V–14V
- Programmable key features
- A voltage out range of 0.7V–2.75V at 0 to 60A.
- Efficiency greater than 92% with a built in heat sink.
- Three phase 500 kHz switching for low ripple noise.
- Flexible Fault Response features
- Multiple turn-on/off slew rates and delays
- Digital Filter Compensation
- Synchronous operation with other supplies
- Real time performance monitoring
- GUI based configuration for short development time.
- Low height of 1.1” suitable for 1U high enclosures
- Approved to the latest edition and amendment of ITE Safety standards, UL/CSA 60950-1 and IEC60950-1

1. ABSOLUTE MAXIMUM RATINGS

Stresses in excess of the absolute maximum ratings may cause performance degradation, adversely affect long-term reliability and cause permanent damage to the converter.

| PARAMETER | CONDITIONS / DESCRIPTION | MIN | MAX | UNITS |
|----------------------|--------------------------|-----|-----|-------|
| Inductor Temperature | Input Voltage applied | -40 | 125 | °C |
| Input Voltage | 250ms Transient | | 15 | VDC |

2. ELECTRICAL SPECIFICATIONS

Specifications apply at the input voltage from 8V to 14V, output load from 0 to 60A, ambient temperature from -40°C to 85°C, and default performance parameters settings unless otherwise noted.

2.1. INPUT SPECIFICATIONS

| PARAMETER | CONDITIONS / DESCRIPTION | MIN | NOM | MAX | UNITS |
|----------------------------|-----------------------------------|-----|-----|-----|-------|
| Input Voltage (V_{IN}) | | 8 | | 14 | VDC |
| Input Current (at no load) | $V_{IN} = 12V$, $V_{OUT} = 2.0V$ | | 290 | | mADC |

2.2. OUTPUT SPECIFICATIONS 1

| PARAMETER | CONDITIONS / DESCRIPTION | MIN | NOM | MAX | UNITS |
|--|--|-----|----------------|------|---------------|
| Output Voltage Range (V_{OUT}) | Programmable within range ² Resolution | 0.7 | | 2.75 | VDC mV |
| Output Voltage Setpoint Resolution | | | 2.5 mV (1LSB) | | |
| Output Voltage Setpoint Accuracy | 2 ND V_O Loop Enabled | | ±(0.6% + 5 mV) | | |
| Output Current (I_{OUT}) | $V_{IN MIN}$ to $V_{IN MAX}$ | -50 | | 60 | ADC |
| Line Regulation | $V_{IN MIN}$ to $V_{IN MAX}$ | | ±0.3 | | % V_{OUT} |
| Load Regulation | 0 to $I_{OUT MAX}$ | | ±0.3 | | % V_{OUT} |
| Dynamic Regulation Peak Deviation Settling Time | 50% - 75% load step, Slew rate 1A/ μ s $F_{SW} = 0.5$ MHz to 10% of peak deviation | | 75 | | mV μ s |
| Output Voltage Peak-to-Peak Ripple and Noise BW=20MHz Full Load | $V_{IN} = 12V$, $V_{OUT} = 0.75V$ | | 15 | | mV |
| | $V_{IN} = 12V$, $V_{OUT} = 1.0V$ | | 20 | | mV |
| | $V_{IN} = 12V$, $V_{OUT} = 1.8V$ | | 25 | | mV |
| | $V_{IN} = 12V$, $V_{OUT} = 2.5V$ | | 30 | | mV |
| Efficiency $F_{SW} = 500$ kHz Full Load Room temperature | $V_{IN} = 12V$, $V_{OUT} = 0.75V$ | | 82.3 | | % |
| | $V_{IN} = 12V$, $V_{OUT} = 1.0V$ | | 85.5 | | % |
| | $V_{IN} = 12V$, $V_{OUT} = 1.2V$ | | 87.4 | | % |
| | $V_{IN} = 12V$, $V_{OUT} = 1.5V$ | | 89.3 | | % |
| | $V_{IN} = 12V$, $V_{OUT} = 1.8V$ | | 90.6 | | % |
| Temperature Coefficient | $V_{IN} = 12V$, $V_{OUT} = 2.5V$, $I_{OUT} = 0.5 \cdot I_{OUT MAX}$ | | TBD | | ppm/°C |
| | Default | | 500 | | kH |
| Switching Frequency | Programmable | 500 | | 500 | kH |
| | Default | | 16.7 | | % |
| Duty Cycle | Default | | 3.125 | | % |
| | Programmable, 1.56% steps | | | 98 | % |

¹ Characteristics assume external output capacitance consisting of 4 x 22 μ F and 1 x 47 uf ceramic XR7 and 4 x 330 μ F 20 mOhm solid electrolytic capacitors unless noted otherwise.

² DP8160G is a step-down converter, thus the output voltage is always lower than the input voltage.

2.3. PROTECTION SPECIFICATIONS

| PARAMETER | CONDITIONS / DESCRIPTION | MIN | NOM | MAX | UNITS |
|---|---|---|-----|------|--|
| OUTPUT OVERCURRENT PROTECTION | | | | | |
| Type | Default Programmable | Non-Latching, 130ms period Latching/Non-Latching | | | |
| Threshold | Default Programmable in 11 steps | 35.2 | 132 | 132 | %I _{OUT} %I _{OUT} |
| Threshold Accuracy | | -20 | | +20 | %I _{OCP.SET} |
| OUTPUT OVERVOLTAGE PROTECTION | | | | | |
| Type | Default Programmable | Non-Latching, 130ms period Latching/Non-Latching | | | |
| Threshold | Default Programmable in 10% steps | 110 ³ | 130 | 130 | %V _{O.SET} %V _{O.SET} |
| Threshold Accuracy | Measured at V _{O.SET} = 2.5V | -2 | | 2 | %V _{OVP.SET} |
| Delay | From instant when threshold is exceeded until the turn-off command is generated | | 6 | | µs |
| Turn Off Behavior ⁴ | Default Programmable to | Catastrophic Off Critical Off / Catastrophic Off | | | |
| OUTPUT UNDERVOLTAGE PROTECTION | | | | | |
| Type | Default Programmable | Non-Latching, 130ms period Latching/Non-Latching | | | |
| Threshold | Default Programmable in 5% steps | 75 | 75 | 90 | %V _{O.SET} %V _{O.SET} |
| Threshold Accuracy | Measured at V _{O.SET} =2.5V | -2 | | 2 | %V _{UVP.SET} |
| Delay | From instant when threshold is exceeded until the turn-off command is generated | | 6 | | µs |
| Turn Off Behavior ⁵ | Default Programmable to | Sequenced Off Sequenced / Critical Off | | | |
| OVERTEMPERATURE PROTECTION | | | | | |
| Type | Default Programmable | Non-Latching, 130ms period Latching/Non-Latching | | | |
| Turn Off Threshold | Temperature is increasing | | 130 | | °C |
| Turn On Threshold | Temperature is decreasing after the module was shut down by OTP | | 120 | | °C |
| Threshold Accuracy | | -5 | | 5 | °C |
| Delay | From instant when threshold is exceeded until the turn-off command is generated | | 6 | | µs |
| Turn Off Behavior ⁵ | Default Programmable to | Sequenced Off Sequenced / Critical Off | | | |
| TRACKING PROTECTION (WHEN ENABLED) | | | | | |
| Type | Default Programmable | Disabled Latching/Non-Latching, 130ms | | | |
| Threshold | Enabled during output voltage ramping up | | | ±250 | mVDC |
| Threshold Accuracy | | -50 | | 50 | mVDC |
| Delay | From instant when threshold is exceeded until the turn-off command is generated | | 6 | | µs |

³ Minimum OVP threshold is 0.5V

⁴ Sequenced Off: The turn-off follows the turn-off delay and slew-rate settings; Critical Off: At turn-off both low and high switches are immediately disabled; Catastrophic Off: At turn-off the high side switch is disabled and the low side switch is enabled.



| OVERTEMPERATURE WARNING | | | | |
|-----------------------------------|---|-----|--|---------------------|
| Threshold | Always enabled, reported in Status register | | 120 | °C |
| Threshold Accuracy | | -5 | +5 | °C |
| Hysteresis | | | 3 | °C |
| Delay | From instant when threshold is exceeded until the warning signal is generated | | 6 | µs |
| POWER GOOD SIGNAL (PG PIN) | | | | |
| Logic | V _{OUT} is inside the PG window | | High | |
| | V _{OUT} is outside the PG window | | Low | |
| Lower Threshold | Default | | 90 | %V _{O.SET} |
| | Programmable in 5% steps | 90 | 95 | %V _{O.SET} |
| Upper Threshold | Default | | 110 | %V _{O.SET} |
| | Programmable in 5% steps | 105 | 110 | %V _{O.SET} |
| Threshold Accuracy | Measured at V _{O.SET} =2.5V | -2 | 2 | %V _{O.SET} |
| PG On Delay ⁵ | Default | | 0 | ms |
| | Programmable to | | 0, 10, 50, 150 | ms |
| PG Off Delay | Default | | PG disabled when Vo reaches low threshold | |
| | Programmable same as PG On Delay | | PG disabled at turn-off command (Reset function) | |

2.4. FEATURE SPECIFICATIONS 6

| PARAMETER | CONDITIONS / DESCRIPTION | MIN | NOM | MAX | UNITS |
|---|---|-------|---------------------|-------------------|-------------------|
| CURRENT SHARE | | | | | |
| Type | | | Active, Single Line | | |
| Maximum Number of Modules Connected in Parallel | | | 4 | | |
| Current Share Accuracy | I _{OUT} ≥ 20% I _{OUT NOM} | | | ±20 | %I _{OUT} |
| INTERLEAVE | | | | | |
| Interleave (Phase Shift) | Default | | 0 | | Degree |
| | Programmable in 22.5° steps | 0 | | 337.5 | Degree |
| SEQUENCING | | | | | |
| Turn ON Delay | Default | | 0 | | ms |
| | Programmable in 1ms steps | 0 | | 255 | ms |
| Turn OFF Delay | Default | | 0 | | ms |
| | Programmable in 1ms steps | 0 | | 63 | ms |
| TRACKING | | | | | |
| Turn ON Slew Rate | Default | | 0.05 | | V/ms |
| | Programmable in 7 steps | 0.05 | | 5.0 ⁷ | V/ms |
| Turn OFF Slew Rate | Default | | -0.05 | | V/ms |
| | Programmable in 7 steps | -0.05 | | -5.0 ⁸ | V/ms |
| OPTIMAL VOLTAGE POSITIONING | | | | | |
| Load Regulation | Default | | 0 | | mV/A |

⁵ From instant when threshold is exceeded until status of PG signal changes high

⁶ Timing based functions such as Turn ON Delay are clock count based and subject to the accuracy limits of the SD signal.

⁷ Achieving fast slew rates under specific line and load conditions may require feedback loop adjustment.

| | | | | |
|--|--|------|-----|-------------------|
| | Programmable in 7 steps | 0 | 1.3 | mV/A |
| FEEDBACK LOOP COMPENSATION | | | | |
| Proportional | Programmable | 0.01 | 2 | |
| Integral | Programmable | 1 | 100 | μs |
| Differential | Programmable | 1 | 100 | μs |
| Differential Roll-Off | Programmable | 1 | 100 | μs |
| MONITORING | | | | |
| Voltage Monitoring Accuracy | 12 Bit Resolution over 0.5...2.75V | -0.5 | 0.5 | % |
| Current Monitoring Accuracy | 20% I _{OUT NOM} < I _{OUT} < I _{OUT NOM} | -20 | +20 | %I _{OUT} |
| Temperature Monitoring Accuracy | Junction temperature of dPOL controller | -5 | +5 | °C |
| REMOTE VOLTAGE SENSE (+VS AND -VS PINS)⁸ | | | | |
| Voltage Drop Compensation | Between +VS and VOUT | | 300 | mV |
| Voltage Drop Compensation | Between -VS and PGND | | 100 | mV |

2.5. SIGNAL SPECIFICATIONS

| PARAMETER | CONDITIONS/DESCRIPTION | MIN | NOM | MAX | UNITS |
|---|--|------------------|-----|------------|------------------|
| VDD | Internal supply voltage | 3.15 | 3.3 | 3.45 | V |
| Logic In Max | Pull Up Logic max safe input | | | VDD+.4 | V |
| SYNC/DATA Line (SD pin) | | | | | |
| ViL_sd | LOW level input voltage | -0.5 | | 0.3 x VDD | V |
| ViH_sd | HIGH level input voltage | 0.75 x VDD | | VDD + 0.5 | V |
| Vhyst_sd | Hysteresis of input Schmitt trigger | 0.25 x VDD | | 0.45 x VDD | V |
| VoL | LOW level sink current @ 0.5V | 16 | | 60 | mA |
| Tr_sd | Maximum allowed rise time 10/90%VDD | | | 300 | ns |
| Cnode_sd | Added node capacitance | | 5 | 10 | pF |
| Ipu_sd | Pull-up current source at Vsd=0V | 0.25 | | 0.75 | mA |
| Freq_sd | SD signal lock range | 475 | | 525 | kHz |
| Tsynq | Sync pulse duration | 22 | | 28 | % of clock cycle |
| T0 | Data=0 pulse duration | 72 | | 78 | % of clock cycle |
| Inputs: ADDR0...ADDR4, EN, IM | | | | | |
| ViL_x | LOW level input voltage | -0.5 | | 0.25 | V |
| ViH_x | HIGH level input voltage | 0.5 x VDD - 0.25 | | VDD+0.5 | V |
| RdnL_ADDR | External pull down resistance ADDR _X forced low | 6 | | 14 | kΩ |
| Power Good and OK Inputs/Outputs | | | | | |
| Iup_PG | Pull-up current source input forced low PG | 30 | | 100 | μA |
| Iup_OK | Pull-up current source input forced low OK | 85 | | 250 | μA |
| ViL_x | LOW level input voltage | -0.5 | | 0.3 x VDD | V |
| ViH_x | HIGH level input voltage | 0.7 x VDD | | VDD+0.5 | V |
| Vhyst_x | Hysteresis of input Schmitt trigger | 0.1 x VDD | | 0.3 x VDD | V |

⁸ If the voltage sense outputs are connected remotely, it is recommended to place a 0.01-0.1μF ceramic capacitor between +VS and -VS pins as close to the dPOL converter as possible. The capacitor improves noise immunity of the dPOL converter.

| | | | | |
|-----------------------------------|--------------------------------------|------------|------------|----|
| IoL | LOW level sink current at 0.5V | 2 | | mA |
| Current Share Bus (CS pin) | | | | |
| Iup_CS | Pull-up current source at VCS = 0V | 0.84 | 2.5 | mA |
| ViL_CS | LOW level input voltage | -0.5 | 0.3 x VDD | V |
| ViH_CS | HIGH level input voltage | 0.75 x VDD | VDD+0.5 | V |
| Vhyst_CS | Hysteresis of input Schmitt trigger | 0.25 x VDD | 0.45 x VDD | V |
| IoL | LOW level sink current at 0.5V | 16 | | mA |
| Tr_CS | Maximum allowed rise time 10/90% VDD | | 100 | ns |

3. PIN ASSIGNMENTS AND DESCRIPTIONS

| PIN NAME | PIN NUMBER | PIN TYPE | BUFFER TYPE | PIN DESCRIPTION | NOTES |
|----------|----------------------|----------|-------------|------------------------|---|
| OK | 3 | I/O | PU | Fault/Status Condition | Connect to OK pin of the DPM and any other dPOLs of the same group. |
| SD | 5 | I/O | PU | Sync/Data Line | Connect to SD pin of DPM |
| PG | 4 | I/O | PU | Power Good | Pin stat reflected in Status Register. |
| CS | 6 | I/O | PU | Current Share | Connect to CS pins of other dPOLs connected in parallel. Leave floating if not on shared bus. |
| ADDR4 | 16 | I | PU | dPOL Address Bit 4 | Tie to GND for 0 or leave floating for 1 |
| ADDR3 | 15 | I | PU | dPOL Address Bit 3 | Tie to GND for 0 or leave floating for 1 |
| ADDR2 | 14 | I | PU | dPOL Address Bit 2 | Tie to GND for 0 or leave floating for 1 |
| ADDR1 | 9 | I | PU | dPOL Address Bit 1 | Tie to GND for 0 or leave floating for 1 |
| ADDR0 | 1 | I | PU | dPOL Address Bit 0 | Tie to GND for 0 or leave floating for 1 |
| -VS | 10 | I | A | Negative Voltage Sense | Connect to the negative point close to the load or PGND |
| +VS | 11 | I | A | Positive Voltage Sense | Connect to the positive point close to the load or VOUT |
| VOUT | 18, 20, 22,24 | P | | Output Voltage | |
| PGND | 7, 8, 17, 19, 21, 23 | P | | Power Ground | |
| VIN | 12, 13 | P | | Input Voltage | |

Legend: I=input, O=output, I/O=input/output, P=power, A=analog, PU=internal pull-up

4. TYPICAL PERFORMANCE CHARACTERISTICS

4.1. DISSIPATION AND EFFICIENCY CURVES

Figure 1. Efficiency at Vin = 8V
Vin = 8.0V

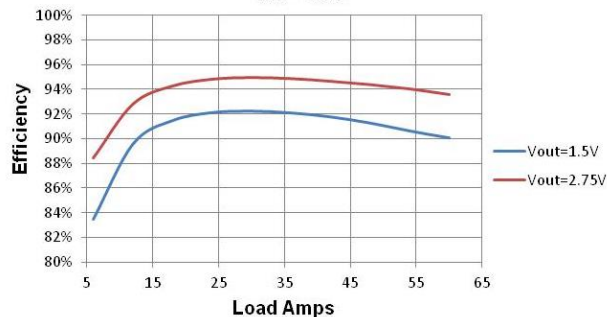

Figure 2. Power Dissipation at Vin = 8V
Vin = 8.0V

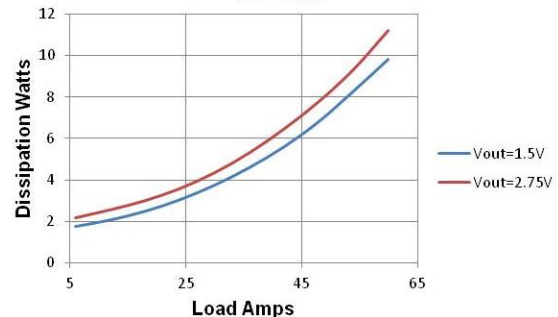

Figure 3. Efficiency vs Load at Vin = 12V

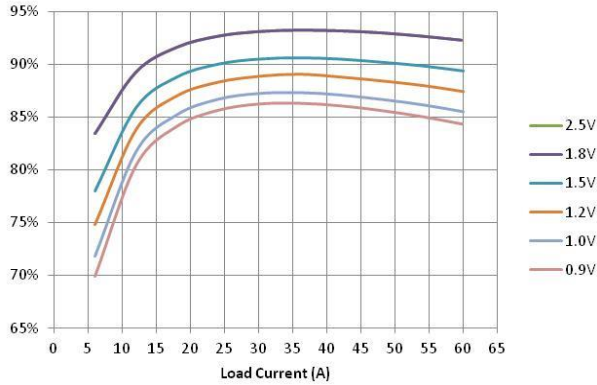
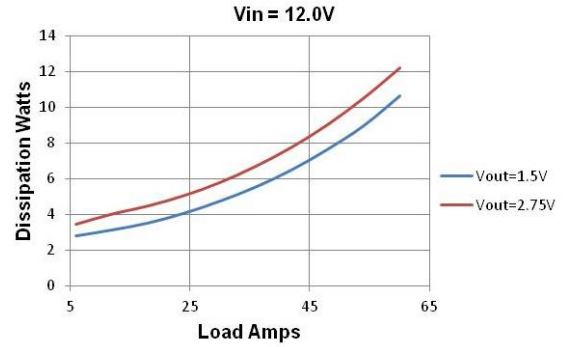
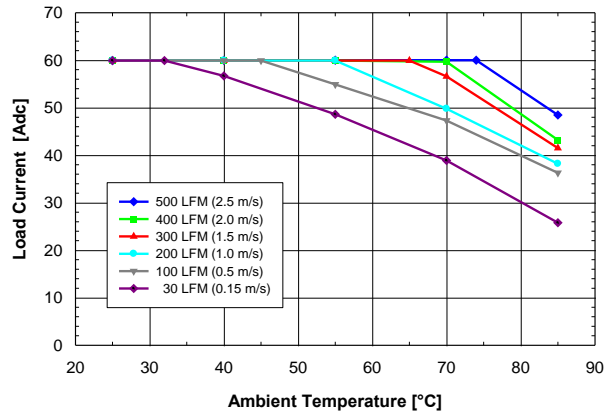

Figure 4. Power Dissipation at Vin = 12V



4.2. THERMAL DERATING

Figure 5. Thermal Derating Curves. Vin=12V, Vout=2.5V



5. PROGRAMMABLE FEATURES

Performance parameters of DP8160G dPOL converters are programmed by the system DPM over a self-clocking single wire bus as need. Each parameter is stored in FLASH memory in the DPM and loaded into volatile memory registers in the dPOL control chip detailed in Table 1. Setup registers 00h through 14h are programmed at the system power-up. When the input voltage is removed, the dPOL controller's default values are restored.

Table 1. DP8160G Memory Registers

| CONFIGURATION REGISTERS | | |
|-------------------------|--|---------|
| Name | Register | Address |
| PC1 | Protection Configuration 1 | 0x00 |
| PC2 | Protection Configuration 2 | 0x01 |
| PC3 | Protection Configuration 3 | 0x02 |
| TC | Tracking Configuration | 0x03 |
| INT | Interleave and Frequency Configuration | 0x04 |
| DON | Turn-On Delay | 0x05 |
| DOF | Turn-Off Delay | 0x06 |
| VLC | Voltage Loop Configuration | 0x07 |
| CLS | Current Limit Set-point | 0x08 |
| DCL | Duty Cycle Limit | 0x09 |
| PC4 | Protection Configuration 4 | 0x0A |
| V1H | Output Voltage Setpoint 1 (Low Byte) | 0x0B |
| V1L | Output Voltage Setpoint 1 (High Byte) | 0x0C |
| V2H | Output Voltage Setpoint 2 (Low Byte) | 0x0D |
| V2L | Output Voltage Setpoint 2 (High Byte) | 0x0E |
| V3H | Output Voltage Setpoint 3 (Low Byte) | 0x0F |
| V3L | Output Voltage Setpoint 3 (High Byte) | 0x10 |
| CP | Controller Proportional Coefficient | 0x11 |
| CI | Controller Integral Coefficient | 0x12 |
| CD | Controller Derivative Coefficient | 0x13 |
| B1 | Controller Derivative Roll-Off Coefficient | 0x14 |
| STATUS REGISTERS | | |
| Name | Register | Address |
| RUN | Run enable / status | 0x15 |
| ST | Status | 0x16 |
| MONITORING REGISTERS | | |
| Name | Register | Address |
| VOH | Output Voltage High Byte (Monitoring) | 0x17 |
| VOL | Output Voltage Low Byte (Monitoring) | 0x27 |
| IO | Output Current (Monitoring) | 0x18 |
| TMP | Temperature (Monitoring) | 0x19 |

DP8160G converters can be programmed using the Graphical User Interface or directly via the I²C bus by using high and low level commands as described in the “DPM Programming Manual”.

DP8160G parameters can be reprogrammed at any time during the system operation and service except for the digital filter coefficients, the switching frequency and the duty cycle limit, that can only be changed when the dPOL output is turned off.

5.1. OUTPUT VOLTAGE

The output voltage can be programmed in the GUI Output Configuration window shown in the Figure 6 or directly via the I²C bus by writing into the VOS register shown in Figure 7.

Figure 6. Output Configuration Window

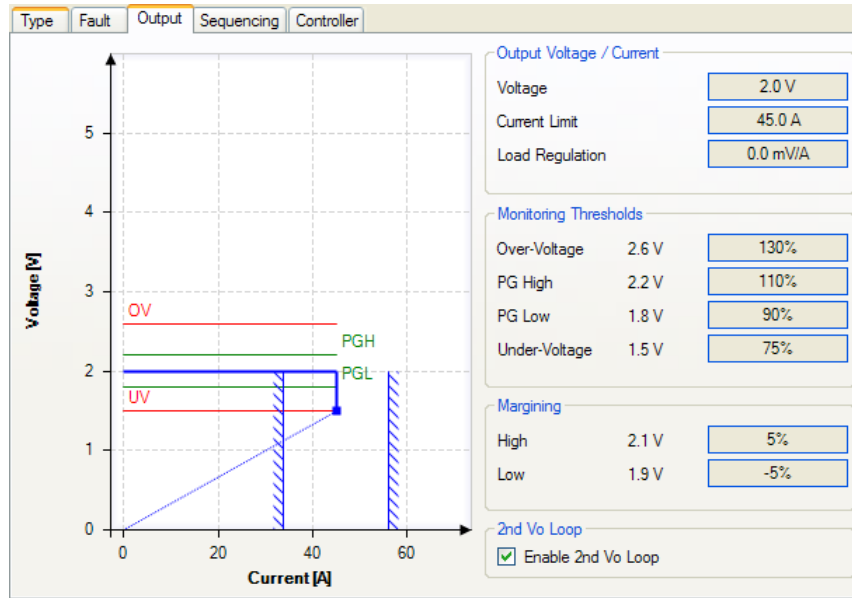

Note that the GUI shows the effect of setting PG, OV and UV limits as both values and graphical limit bars. Vertical hashed lines are error bars for the Overcurrent (OC) limit.

5.1.1. Output Voltage Setpoint

The output voltage programming range is from 0.7 V to 2.75 V. The resolution is constant across the range and is 2.5 mV. A Total of 3 registers are provided: one should be used for the normal setpoint voltage; the other two can be used to define a low/high margining voltage setpoint. Note that each register is 16bit wide and that the high byte needs always to be written / read first. The writing of the low byte triggers the refresh of the whole 16bit register (the high byte is written to a shadow register).

Unlike other configuration registers, the dPOL controller's VOS registers are dynamic. Changes to VOS values can be made while the output is enabled over the I²C bus through register bypass commands and the dPOL will change its output immediately.

Figure 7. Output Voltage Setpoint Register VOS

VOS: Output Voltage Set-Point
Address: 0x0B ... 0x10

| | Coefficient | Addr | Bits | Default |
|-----|------------------------------|------|------|---------|
| V1H | First Vo Setpoint High Byte | 0x0B | 8 | |
| V1L | First Vo Setpoint Low Byte | 0x0C | 8 | |
| V2H | Second Vo Setpoint High Byte | 0x0D | 8 | |
| V2L | Second Vo Setpoint Low Byte | 0x0E | 8 | |
| V3H | Third Vo Setpoint High Byte | 0x0F | 8 | |
| V3L | Third Vo Setpoint Low Byte | 0x10 | 8 | |

Mapping:

- 12 bit data word, left aligned
- 1LSB = 2.5mV

Note:

- all registers are readable and writeable
- always write and read the high byte first

5.1.2. Output Voltage Margining

If the output voltage needs to be varied by a certain percentage, the margining function can be utilized. The margining can be programmed in the dPOL Configuration window or directly via the I²C bus using high level commands as described in the "DM7300 Digital Power Manager Programming Manual".

In order to properly margin dPOLs that are connected in parallel, the dPOLs must be members of one of the Parallel Buses. Refer to the GUI System Configuration Window shown in Figure 46.



5.1.3. Output Load Regulation Control

Load Regulation provides for dynamic output voltage change proportional to load current. This feature helps to improve step load response by changing the VI characteristic slope at the point of regulation. This parameter can be programmed in the GUI Output Configuration window shown in Figure 6 or directly via the I²C bus. In the DP8160G Load Regulation can be set to one of eight values: 0, 0.12, 0.24, 0.37, 0.49, 0.61, 0.73, or 0.86 mV/A.

Figure 8. Concept of Optimal Voltage Positioning

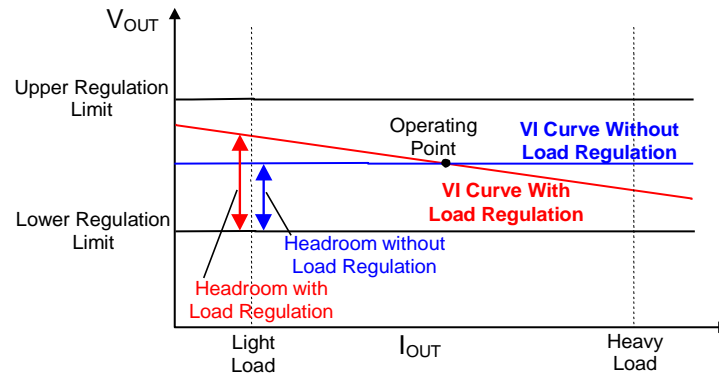

Figure 8 shows a DP8160G dPOL with 0 mV/A (load current) regulation setting. Alternating high and low output load currents causes large transients in V_{out} to appear with each change.

Figure 9. Transient Response without Optimal Voltage Positioning

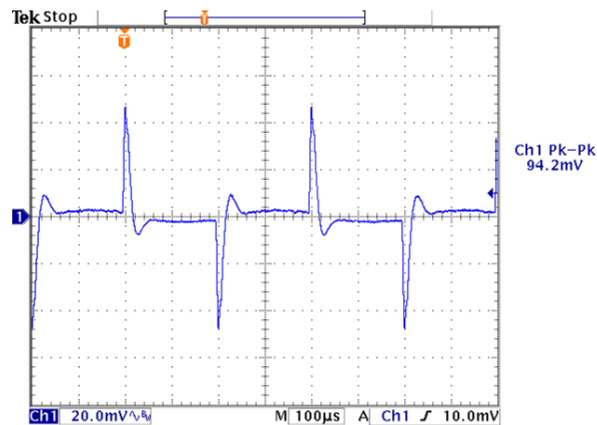
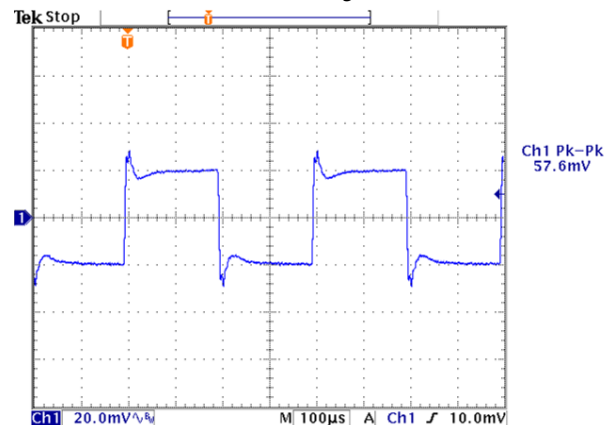

Figure 10. Transient Response with Optimal Voltage Positioning



As the Load Regulation parameter is increased, step offsets in output voltage begin to appear, as shown in Figure 9.

The Load Regulation parameter is an important part of Current Sharing. It is used to set one dPOL as a "master", by assigning a lower mV/A load regulation than all other dPOLs which share the load as "slaves". The dPOL with the lowest Regulation parameter sets the effective overall regulation. (See Current Sharing elsewhere in this document.)

5.2. SEQUENCING AND TRACKING

Turn-on delay, turn-off delay, and rising and falling output voltage slew rates can be programmed in the GUI Sequencing/Tracking window shown in Figure 11 or directly via the I²C bus by writing into the DON, DOF, and TC registers, respectively. The registers are shown in Figure 12, Figure 14, and Figure 15.

Figure 11. Sequencing/Tracking Window

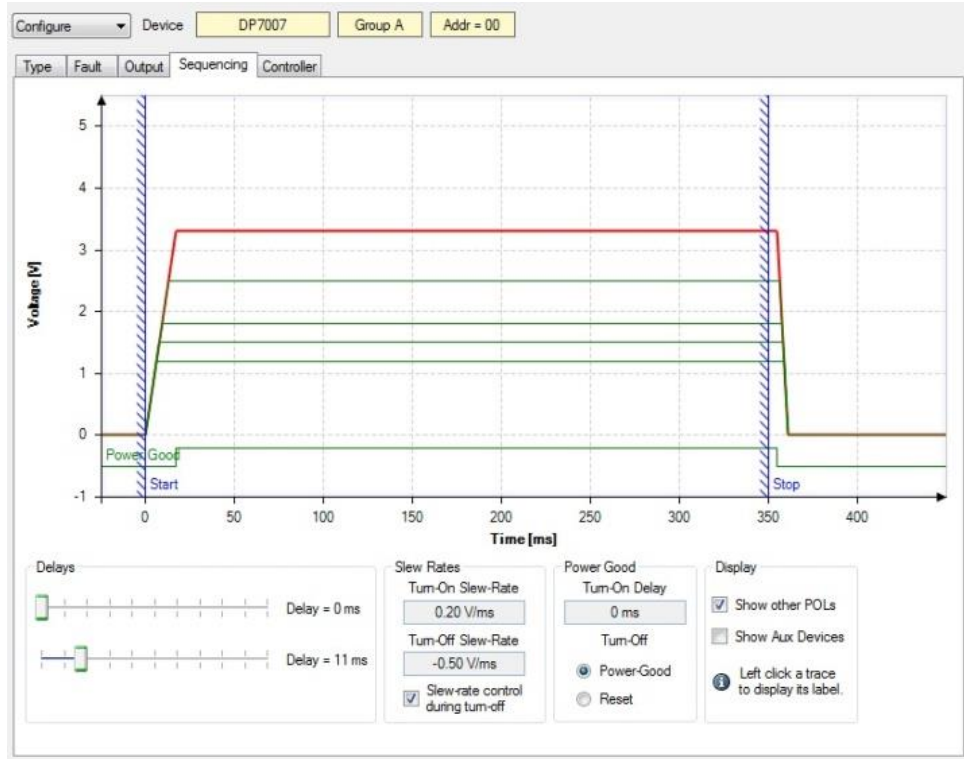

5.2.1. Turn-On Delay

Turn-on delay is defined as an interval from the application of the Turn-On command until the output voltage starts ramping up.

Figure 12. Turn-On Delay Register DON

| | | | | | | | |
|--|-------------|-------------|-------------|-------------|-------------|-------------|-------------|
| DON: Turn-On Delay Configuration | | | | | | | |
| Address: 0x05 | | | | | | | |
| R/W-0 | R/W-0 | R/W-0 | R/W-0 | R/W-0 | R/W-0 | R/W-0 | R/W-0 |
| DON7 | DON6 | DON5 | DON4 | DON3 | DON2 | DON1 | DON0 |
| Bit 7 | | | | | | | Bit 0 |
| <p>DON[7:0]: Turn-On delay in ms 0x00 = 0ms (default) Bit 7:0 0x01 = 1ms ... 0xFF = 255ms</p> | | | | | | | |

5.2.2. Turn-Off Delay

Turn-off delay is defined as an interval from the application of the Turn-Off command until the output voltage reaches zero (if the falling slew rate is programmed) or until both high side and low side switches are turned off (if the slew rate is not programmed). Therefore, for the slew rate controlled turn-off the ramp-down time is included in the turn-off delay as shown in Figure 13.

Figure 13. Relationship between Turn-Off Delay and Falling Slew Rate

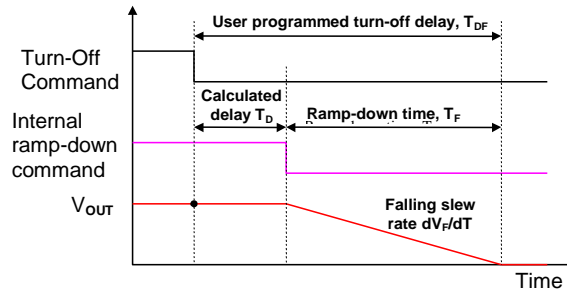

As it can be seen from the figure, the internally calculated delay T_D is determined by the equation below.

$$T_D = T_{DF} - \frac{V_{OUT}}{dV_F/dT}$$

For proper operation T_D shall be greater than zero. The appropriate value of the turn-off delay needs to be programmed to satisfy the condition.

If the falling slew rate control is not utilized, the turn-off delay only determines an interval from the application of the Turn-Off command until both high side and low side switches are turned off. In this case, the output voltage ramp-down process is determined by load parameters.

Figure 14. Turn-Off Delay Register DOF

DOF: Turn-Off Delay Configuration
Address: 0x06

| U | U | R/W-0 | R/W-0 | R/W-1 | R/W-0 | R/W-1 | R/W-1 |
|---------|---------------------------------------|-------|-------|-------|-------|-------|-------|
| --- | --- | DOF5 | DOF4 | DOF3 | DOF2 | DOF1 | DOF0 |
| Bit 7 | | | | | | | Bit 0 |
| Bit 7:6 | Unimplemented: read as '0' | | | | | | |
| | DOF[5:0]: Turn-Off delay in ms | | | | | | |
| | 0x00 = 0ms | | | | | | |
| | 0x01 = 1ms | | | | | | |
| Bit 5:0 | ... | | | | | | |
| | 0x0B = 11ms (default) | | | | | | |
| | ... | | | | | | |
| | 0x3F = 63ms | | | | | | |

5.3. TURN-ON/OFF CONTROL

Once delays are accounted for, turn-on and turn-off characteristics are simply a function of slew rates, which are selectable.

5.3.1. Rising and Falling Slew Rates

Output voltage ramp up (and down) control is accomplished by programming the rising and falling slew rates of the output voltage, supported in the GUI as shown in Figure 11, which is implemented by the DPM through writing data to the TC register, Figure 15.

To achieve programmed slew rates, the output voltage is being changed in 10mV steps where duration of each step determines the slew rate. For example, ramping up a 1.0V output with a slew rate of 0.5V/ms will require 100 steps duration of 20µs each.

Duration of each voltage step is calculated by dividing the master clock frequency generated by the DPM. Since all dPOLs in the system are synchronized to the master clock, the matching of voltage slew rates of different outputs is very accurate as it can be seen in Figure 16 and Figure 21.

During the turn on process, a dPOL not only delivers current required by the load (I_{LOAD}), but also charges the load capacitance. The charging current can be determined from the equation:

$$I_{CHG} = C_{LOAD} \times \frac{dV_R}{dt}$$

Where, C_{LOAD} is load capacitance, dV_R/dt is rising voltage slew rate, and I_{CHG} is charging current.

Figure 15. Tracking Configuration Register TC

| TC: Tracking Configuration | | | | | | | |
|----------------------------|---|-------|-------|-------|-------|-------|-------|
| Address: 0x03 | | | | | | | |
| U | R/W-0 | R/W-0 | R/W-1 | R/W-1 | R/W-1 | R/W-0 | R/W-0 |
| --- | R2 | R1 | R0 | SC | F2 | F1 | F0 |
| Bit 7 | | | | | | | Bit 0 |
| Bit 7 | Unimplemented: read as '0' R[2:0]: Vo rising slew rate 0 = 0.05 V/ms (default when in bus terminator mode) 1 = 0.1 V/ms (default) 2 = 0.2 V/ms 3 = 0.25 V/ms 4 = 0.5 V/ms 5 = 1.0 V/ms 6 = 2.0 V/ms 7 = Reserved | | | | | | |
| Bit 6:4 | SC: Turn-off slew rate control 0 = disabled 1 = enabled (default) | | | | | | |
| Bit 3 | F[2:0]: Vo falling slew rate 0 = -0.05 V/ms 1 = -0.1 V/ms 2 = -0.2 V/ms 3 = -0.25 V/ms (default when in bus terminator mode) 4 = -0.5 V/ms (default) 5 = -1.0 V/ms 6 = -2.0 V/ms 7 = -Reserved | | | | | | |
| Bit 2:0 | | | | | | | |

When selecting the rising slew rate, a user needs to ensure that

$$I_{LOAD} + I_{CHG} < I_{OCP}$$

Where I_{OCP} is the overcurrent protection threshold of the DP8160. If the condition is not met, then the overcurrent protection will be triggered during the turn-on process. To avoid this, dV_R/dt and the overcurrent protection threshold should be programmed to meet the condition above.

5.3.2. Delay and Slew Rate Combination

The effect of setting slew rates and turn on/off delays is illustrated in the following sets of figures.

Figure 16. Tracking Turn-On. Rising Slew Rate is Programmed at 0.5V/ms. Vin=12V

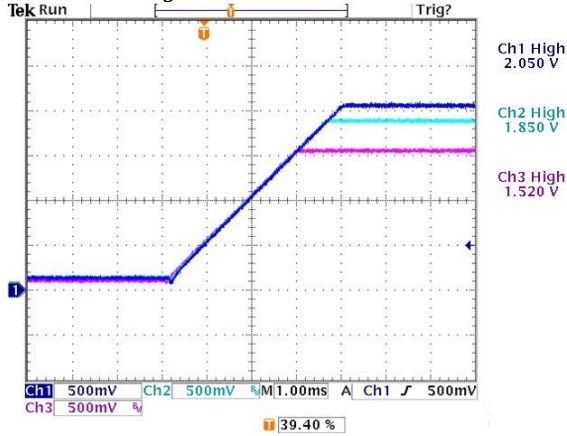

Figure 17. Turn-On with Slew Rates Programmed as follows V1 at 1.0V/ms, V2 at 0.5V/ms, V3 at 0.2V/ms. Vin=12V

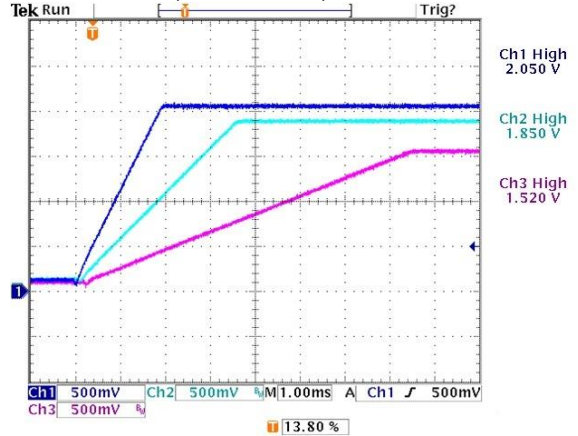

Figure 18. Turn On with Sequencing and Tracking. Rising Slew Rate Programmed at 0.5V/ms, V1 and V2 delays are programmed at 5ms. Vin=12V

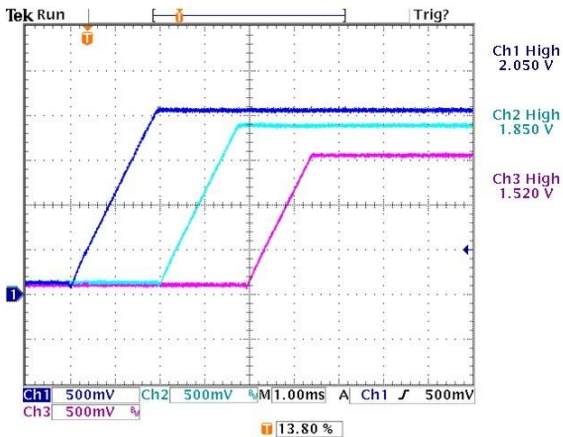
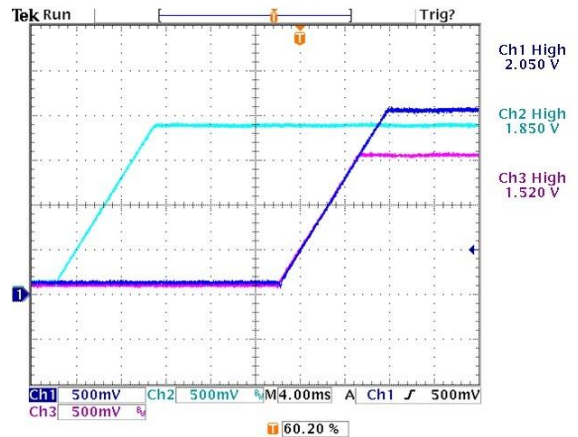

Figure 19. Two outputs delayed 5ms. All slew rates at 0.5V/ms



5.3.3. Pre-Bias

In some applications, power may "leak" from a powered circuit to an unpowered bus, typically through ESD protection diodes. The d-pwer® controller in the DP7120 holds off turn on its output until the desired ramp up point crosses the pre-bias point, as seen in Figure 20.

Figure 20. Turn On into Prebiased Load. V1 and V2 are Prebiased by V3 via a Diode. Vin=12V

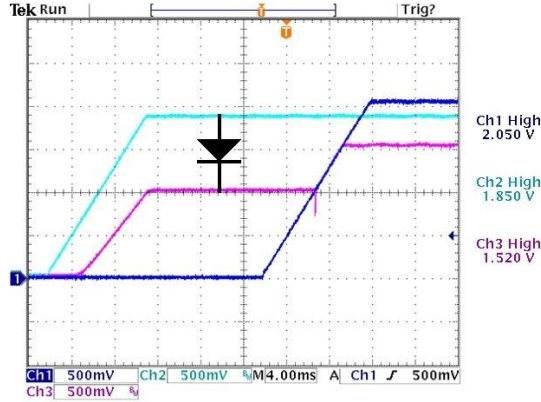

Figure 20 was captured with an actual system where a diode was added to pre-bias a 1.5V bus from a 1.85V bus in order to simulate the effect of current leakage through protection circuits of unpowered logic connected to powered logic outputs (a common source of pre-bias in power systems).

5.4. TURN-OFF CHARACTERISTICS

Turn of captures show that combining turn off delays and ramp rates. Note that while turnoff delays have a lower upper time limit as compared to turn on delays, all ramp down rates are available independently to turn on and off.

Figure 21. Tracking Turn-Off. Falling Slew Rate is Programmed at 0.5V/ms. Vin=12V

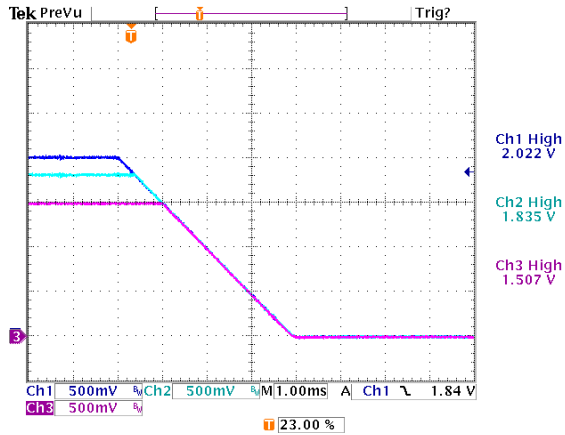
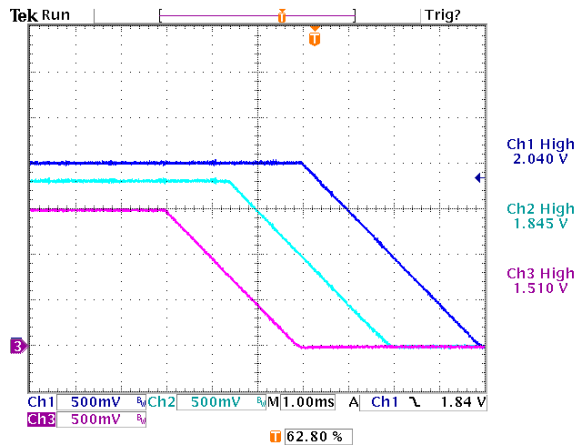

Figure 22. Turn-Off with Tracking and Sequencing. Falling Slew Rate is Programmed at 0.5V/ms. Vin=12V



5.5. FAULTS, ERRORS AND WARNINGS

All dPOL series converters have a comprehensive set of programmable fault and error protection functions that can be classified into three groups based on their effect on system operation: warnings, faults, and errors. These are *warnings*, *errors* and *faults*. Warnings include Thermal (Overtemperature limit near) and Power Good (a warning in a negative sense.)

Faults in dP series POLs include overcurrent protection, overvoltage, overtemperature and tracking failure detection. Errors include only undervoltage. Control of responses to Faults and Errors are distributed between different dPOL registers and are configurable in the GUI.

Thresholds of overcurrent, over- and undervoltage protections, and Power Good limits can be programmed in the GUI Output Configuration window or directly via the I²C bus by writing into the CLS and PC2 registers shown in Figure 24 and Figure 23.

Figure 23. Protection Configuration Register PC2

| PC2: Protection Configuration Register 2 ¹⁾ | | | | | | | |
|--|--|-------|-------|-------|-------|-------|-------|
| Address: 0x01 | | | | | | | |
| U | U | R/W-0 | R/W-0 | R/W-1 | R/W-0 | R/W-0 | R/W-0 |
| --- | --- | PGHL | PGLL | OVPL1 | OVPL0 | UVPL1 | UVPL0 |
| Bit 7 | | | | | | | Bit 0 |
| Bit7:6 | Unimplemented: read as '0' | | | | | | |
| | PGHL: Power Good High Level | | | | | | |
| Bit 5 | 1 = 105% of Vo 0 = 110% of Vo (default) | | | | | | |
| | PGLL: Power Good Low Level | | | | | | |
| Bit 4 | 1 = 95% of Vo 0 = 90% of Vo (default) | | | | | | |
| | OVPL: Over Voltage Protection Level | | | | | | |
| Bit 3:2 | 00 = 110% of Vo 01 = 120% of Vo 10 = 130% of Vo (default) 11 = 130% of Vo | | | | | | |
| | UVPL: Under Voltage Protection Level | | | | | | |
| Bit 1:0 | 00 = 75% of Vo (default) 01 = 80% of Vo 10 = 85% of Vo 11 = 90% of Vo | | | | | | |
| ¹⁾ This register can only be written when PWM is not active (RUN[RUN] is '0') | | | | | | | |

Note that the overvoltage and undervoltage protection thresholds and Power Good limits are defined as percentages of the output voltage. Therefore, the absolute levels of the thresholds change when the output voltage setpoint is changed either by output voltage adjustment or by margining.

Overcurrent limits are set either in the GUI POL Output configuration dialog or in the dPOL's CLS register as shown in Figure 24.

Note that the CLS register includes bits which control the Regulation option settings. When writing into this register be careful to not change Regulation by accident.

Figure 24. Current Limit Setpoint Register CLS

| CLS: Current Limit Setting | | | | | | | |
|----------------------------|--|-------|-------|-------|-------|-------|-------|
| Address: 0x08 | | | | | | | |
| R/W-0 | R/W-0 | R/W-0 | R/W-1 | R/W-1 | R/W-0 | R/W-1 | R/W-1 |
| LR2 | LR1 | LR0 | TCE | CL3 | CL2 | CL1 | CL0 |
| Bit 7 | | | | | | | Bit 0 |
| | LR[2:0]: Load Regulation setting | | | | | | |
| | 0 = 0 V/A/Ω (default) 1 = 0.39 V/A/Ω 2 = 0.78 V/A/Ω | | | | | | |
| Bit 7:5 | 3 = 1.18 V/A/Ω 4 = 1.57 V/A/Ω 5 = 1.96 V/A/Ω 6 = 2.35 V/A/Ω 7 = 2.75 V/A/Ω | | | | | | |
| Bit 4 | TCE: Temperature Compensation for Current Limitation Enable | | | | | | |



| | |
|---------|--|
| | 0 = disabled |
| | 1 = enabled (default) |
| | CLS[3:0]: Current Limit set-point when Vo Stationary or Falling |
| | 0x0 = 37% |
| Bit 3:0 | 0x1 = 47% |
| | ... |
| | 0xB = 140% (default) values higher than 0xB are translated to 0xB (140%) |

5.5.1. Warnings

This group includes Overtemperature Warning and Power Good Signal. The warnings do not turn off dPOLs but rather generate signals that can be transmitted to a host controller via the I²C bus.

5.5.1.1. Overtemperature Warning

The Overtemperature Warning is generated when temperature of the controller exceeds 120°C. The Overtemperature Warning changes the PT bit of the status register ST. When the temperature falls below 117°C, the PT bit is cleared and the Overtemperature Warning is removed.

5.5.1.2. Power Good

Power Good (PG) is an open collector output that is pulled low, if the output voltage is outside of the Power Good window. The window is formed by the Power Good High threshold that is programmable at 105 or 110% of the output voltage and the Power Good Low threshold that can be programmed at 90 or 95% of the output voltage.

The Power Good protection is only enabled after the output voltage reaches its steady state level. A programmable delay can be set between 0 and 150ms to delay the release of the PG pin after the voltage has reached the steady state level (see Figure 11). This allows using the PG pin to reset load circuits properly. The Power Good protection remains active during margining voltage transitions. The threshold will vary proportionally to the voltage change (see Figure 25).

The Power Good Warning pulls the PG pin low and changes the PG bit of the status register ST to 0. When the output voltage returns within the Power Good window, the PG pin is released high, the PG bit is cleared and the Power Good Warning is removed. The Power Good pin can also be pulled low by an external circuit to initiate the Power Good Warning.

At turn-off the PG pin can be programmed to either be pulled low immediately following the turn-off command, or then when the voltage actually starts to ramp down (Reset vs. Power Good functionality in Figure 11).

Note: To retrieve status information, Status Monitoring in the GUI dPOL Group Configuration Window should be enabled (refer to Digital Power Manager Data Sheet). The DPM will retrieve the status information from each dPOL on a continuous basis.

5.5.2. Faults

This group includes overcurrent, overtemperature, undervoltage, and tracking protections. Triggering any protection in this group will turn off the dPOL. For UV and OT faults the turn-off can be programmed to sequenced or critical turn-off behavior:

5.5.2.1. Overcurrent Protection

Overcurrent protection is active whenever the output voltage of the dPOL exceeds the prebias voltage (if any). When the output current reaches the OC threshold, the POL control chip asserts an OC fault. The dPOL sets the OC bit in the register ST to 0. Both high side and low side switches of the dPOL are turned off instantly (fast turn-off).

Current sensing is across the dPOLs choke. To compensate for copper winding T_c, compensation is added to keep the OC threshold approximately constant at temperatures above room temperature. Note that the temperature compensation can be disabled in the dPOL Configure Output window or directly via the I²C by writing into the CLS register. However, it is recommended to keep the temperature compensation enabled.

5.5.2.2. Undervoltage Protection

The undervoltage protection is only active during steady state operation of the dPOL to prevent nuisance tripping. If the output voltage decreases below the UV threshold and there is no OC fault, the UV fault signal is generated, the dPOL turns off, and the UV bit in the register ST is changed to 0. The dPOL switch-off can be programmed to follow a sequenced or critical turn-off.

5.5.2.3. Overtemperature Protection

Overtemperature protection is active whenever the dPOL is powered up. If temperature of the controller exceeds 120°C, the OT fault is generated, dPOL turns off, and the OT bit in the register ST is changed to 0. The dPOL switch-off can be programmed to follow a sequenced or critical turn-off.

If non-latching OTP is programmed, the dPOL will restart as soon as the temperature of the controller decreases below the Overtemperature Warning threshold of 110°C.

5.5.2.4. Tracking Protection

Ramp up and down operations are under control by the dPOL. Tracking protection, however, is active only when the output voltage is ramping up. The purpose of the protection is to ensure that the voltage differential between multiple rails being tracked does not exceed 250mV. This protection eliminates the need for external clamping diodes between different voltage rails which are frequently recommended by ASIC manufacturers.

When the tracking protection is enabled, the dPOL continuously compares actual value of the output voltage to its programmed value as defined by the output voltage and its rising slew rate. If absolute value of the difference exceeds 250mV, the tracking fault signal is generated, the dPOL turns off, and the TR bit in the register ST is changed to 0. Both high side and low side switches of the dPOL are turned off instantly (fast turn-off).

The tracking protection can be disabled, if it contradicts requirements of a particular system (for example turning into high capacitive load where rising slew rate is not important). It can be disabled in the dPOL Configure Fault window or directly via the I²C bus by writing into the PC1 register.

5.5.3. Faults and Margining

As noted earlier, UV and OV protection settings are a percentage of Vout. As Vout ramps between nominal, low or high margin values, UVP and OVP limits adjust accordingly. This is illustrated in Figure 25. The middle plot of Vo (Vout) level is the result of a Low Margining command. Note that Tracking is not re-enabled during changes to Vout from margining commands.

Figure 25. Protections Enable Conditions

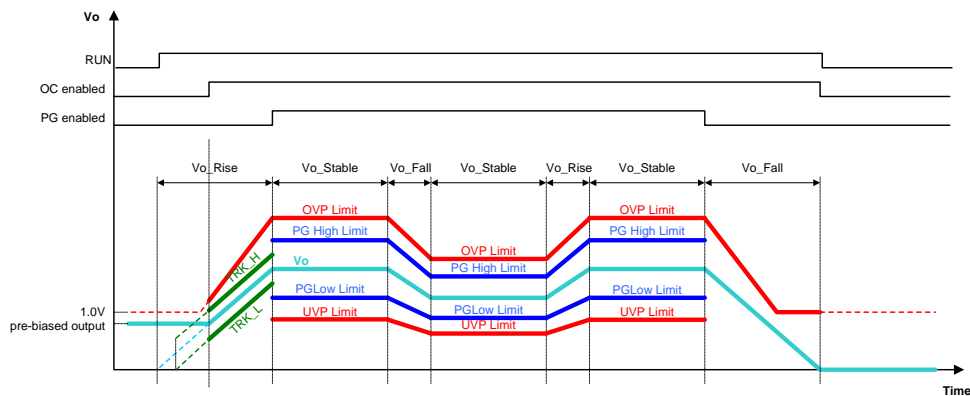

5.5.4. Errors

This protection group includes only overvoltage protection.

5.5.4.1. Overvoltage Protection

The overvoltage protection is set as a percentage of Vout. It is active whenever the output voltage of the dPOL exceeds the pre-bias voltage (if any). If the output voltage exceeds the overvoltage protection threshold, the overvoltage error signal is generated, the dPOL turns off, and the OV bit in the register ST is changed to 0. The high side switch is turned off instantly, and simultaneously the low side switch is turned on to ensure reliable protection of sensitive loads. The low side switch provides low impedance path to quickly dissipate energy stored in the output filter and achieve effective voltage limitation. The OV threshold can be programmed from 110% to 130% of the output voltage setpoint, but not lower than 0.5V. Also the OV threshold will always be at least 0.25V above the setpoint.

5.5.5. Fault and Error Latching

The user has the option of setting up any protection option as either latching/non-latching and propagating or non-propagating.

Propagation and Latching for each dPOL is set up in the GUI Device / Configure / Faults dialog for dPOL, as shown in Figure 26, and readable the dPOL register ST1 (Figure 27).



Figure 26. dPOL Fault Management Window

| Type | Fault | Output | Sequencing | Controller | |
|------|-------------------------|-------------------------------------|--------------------------|-------------------------------------|-----------------|
| | Trigger | Enable | Latching | Propagate | Turn-Off |
| | Tracking Differential → | <input type="checkbox"/> | <input type="checkbox"/> | <input checked="" type="checkbox"/> | Critical |
| | Over-Temperature → | <input type="checkbox"/> | <input type="checkbox"/> | <input checked="" type="checkbox"/> | Sequenced |
| | Over-Current → | <input type="checkbox"/> | <input type="checkbox"/> | <input checked="" type="checkbox"/> | Critical |
| | Under-Voltage → | <input type="checkbox"/> | <input type="checkbox"/> | <input checked="" type="checkbox"/> | Sequenced |
| | Over-Voltage → | <input checked="" type="checkbox"/> | <input type="checkbox"/> | <input checked="" type="checkbox"/> | Emergency |

If the non-latching protection is selected, a dPOL will attempt to restart every 130ms until the condition that triggered the protection is removed. When restarting, the output voltages follow tracking and sequencing settings. If the latching type is selected, a dPOL will turn off and stay off. The dPOL can be turned on after 130ms, if the condition that caused the fault is removed and the respective bit in the ST register was cleared, or the Turn On command was recycled, or the input voltage was recycled.

Figure 27. Protection Configuration Register PC1

| | | | | | | | |
|--|--|------------|------------|------------|------------|------------|------------|
| PC1: Protection Configuration Register 1 | | | | | | | |
| Address: 0x00 | | | | | | | |
| R/W-0 | R/W-1 | R/W-0 | R/W-0 | R/W-0 | R/W-0 | R/W-1 | R/W-1 |
| TRE | PVE | TRC | OTC | OCC | UVC | OVC | PVC |
| Bit 7 | | | | | | | Bit 0 |
| Bit 7 | TRE: Tracking fault enable | | | | | | |
| | 1 = enabled | | | | | | |
| | 0 = disabled | | | | | | |
| Bit 6 | PVE: Phase voltage error enable | | | | | | |
| | 1 = enabled | | | | | | |
| | 0 = disabled | | | | | | |
| Bit 5 | TRC: Tracking Fault Protection Configuration | | | | | | |
| | 1 = latching | | | | | | |
| | 0 = non-latching | | | | | | |
| Bit 4 | OTC: Over Temperature Protection Configuration | | | | | | |
| | 1 = latching | | | | | | |
| | 0 = non-latching | | | | | | |
| Bit 3 | OCC: Over Current Protection Configuration | | | | | | |
| | 1 = latching | | | | | | |
| | 0 = non-latching | | | | | | |
| Bit 2 | UVC: Under Voltage Protection Configuration | | | | | | |
| | 1 = latching | | | | | | |
| | 0 = non-latching | | | | | | |
| Bit 1 | OVC: Over Voltage Protection Configuration | | | | | | |
| | 1 = latching | | | | | | |
| | 0 = non-latching | | | | | | |
| Bit 0 | PVC: Phase Voltage Protection Configuration | | | | | | |
| | 1 = latching | | | | | | |
| | 0 = non-latching | | | | | | |

5.5.6. Fault and Error Turn Off Control

In the GUI dPOL Fault dialog is a column of spin controls which set the Turn-Off style OT, UV and OV events. The choices are defined as:

Sequenced: Outputs shut down according to ramp down rate control settings. This is the method used when a dPOL is told to do a normal, controlled shut down.

Critical: Both high side and low side switches of the dPOL are turned off instantly

Emergency: The high side switch is turned off instantly, and simultaneously the low side switch is turned on to ensure reliable protection of sensitive loads

5.5.7. Fault and Error Status

The status of each protection circuit is stored in the ST register shown in Figure 28. When Status monitoring is enabled for a group, the DPM will read this register and make the information available for uses such as GUI Monitor display.

Figure 28. Protection Status Register ST

ST: Status register
Address: 0x16

| R-1 | R-0 | R/W-1 ¹⁾ | R/W-1 ¹⁾ | R/W-1 ¹⁾ | R/W-1 ¹⁾ | R/W-1 ¹⁾ | R/W-1 ¹⁾ |
|-------|--|---------------------|---------------------|---------------------|---------------------|---------------------|---------------------|
| TW | PG | TR | OT | OC | UV | OV | PV |
| Bit 7 | | | | | | | Bit 0 |
| Bit 7 | TW: Temperature Warning | | | | | | |
| Bit 6 | PG: Power Good Warning (high and low) | | | | | | |
| Bit 5 | TR: Tracking Fault | | | | | | |
| Bit 4 | OT: Over Temperature Fault | | | | | | |
| Bit 3 | OC: Over Current Fault | | | | | | |
| Bit 2 | UV: Under Voltage Fault | | | | | | |
| Bit 1 | OV: Over Voltage Error | | | | | | |
| Bit 0 | PV: Phase Voltage Error | | | | | | |

Note: an activated fault is encoded as '0'
¹⁾ Writing a '1' into a fault/error bit clears a latching fault/error

5.5.8. Fault and Error Propagation

The feature adds flexibility to the fault management scheme by giving users control over propagation of fault signals within and outside of the system. The propagation means that a fault in one dPOL can be programmed to turn off other dPOLs and devices in the system, even if they are not directly affected by the fault.

5.5.8.1. Fault Propagation

When propagation is enabled, the faulty dPOL pulls its OK pin low. This signals to the DPM and any other dPOL connected to that signal, that the dPOL has a Fault or Error condition. A low OK line initiates turn-off of other dPOLs connected to the same OK line with the same turn-off behavior as the faulty dPOL. The turn-off type is encoded into the OK line when it transitions from high to low.

5.5.9. Grouping of dPOLs

Interconnecting dPOL OK lines a dPOLs can be arranged in several groups to simplify fault management. A group of dPOLs is defined as a number of dPOLs with interconnected OK pins. A group can include from 1 to 32 dPOLs. If fault propagation within a group is desired, the propagation bit needs to be checked in the GUI Fault Management Window. The parameters can also be programmed directly via the I²C bus by writing into the PC3 register shown in Figure 30.

In order for a particular Fault or Error to propagate through the OK line to other groups, Propagation needs to be checked in the GUI dPOL **Configure / Fault** Management Window shown in Figure 29.

Figure 29. Fault and Error Propagation Window



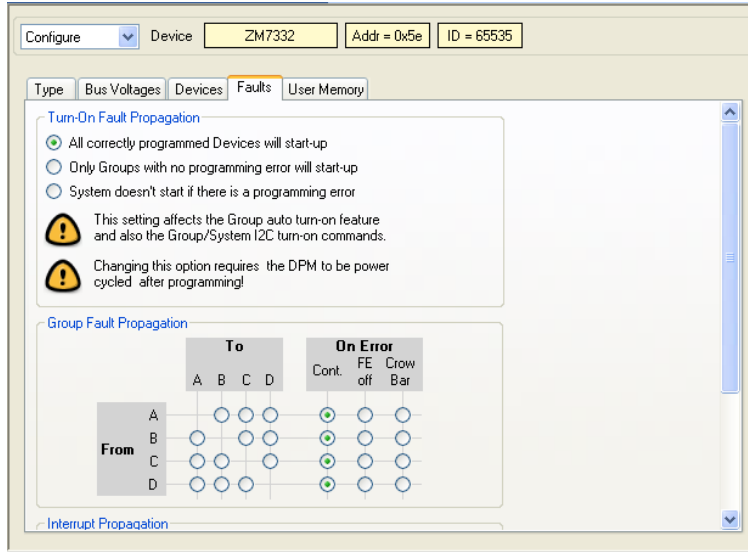

Note that the turn-off type of the fault as it propagates through the DPM will remain unchanged. Propagation options for dPOLs can be read or set in the dPOL PC3 register shown in Figure 30.

Figure 30. Protection Configuration Register PC3

PC3: Protection Configuration Register 3
Address: 0x02

| U | U | R/W-1 | R/W-1 | R/W-1 | R/W-1 | R/W-1 | R/W-1 |
|---------|--|-------|-------|-------|-------|-------|-------|
| --- | --- | TRP | OTP | OCP | UVP | OVP | PVP |
| Bit 7 | | | | | | | Bit 0 |
| Bit 7:6 | Unimplemented: Read as '0' | | | | | | |
| Bit 5 | TRP: Tracking Protection Propagation 0 = disabled 1 = enabled | | | | | | |
| Bit 4 | OTP: Over Temperature Protection Propagation 0 = disabled 1 = enabled | | | | | | |
| Bit 3 | OCP: Over Current Protection Propagation 0 = disabled 1 = enabled | | | | | | |
| Bit 2 | UVP: Under Voltage Protection Propagation 0 = disabled 1 = enabled | | | | | | |
| Bit 1 | OVP: Over Voltage Protection Propagation 0 = disabled 1 = enabled | | | | | | |
| Bit 0 | PVP: Phase Voltage Protection Propagation 0 = disabled 1 = enabled | | | | | | |

5.5.10. Front End and Crowbar

As shown in the propagation dialog, if an error is propagated, the DPM can be configured to generate commands to turn off a front end (a DC-DC converter generating the intermediate bus voltage) or trigger crowbar protection to accelerate removal of the IBV voltage. (The two options are independent of inter-group propagation, and may require some external hardware to interface to the IBV or crow-bar SCR device.

5.5.11. Propagation Examples

Understanding Fault and Error propagation is easier with the following examples.

The First example is of of non-propagation from a dPOL, as shown in Figure 31. An undervoltage error shuts down the Vo, but since propagation was not enabled, OK-A is not pulled down and Vo2 stays up.

Figure 31. No Group Fault Propagation

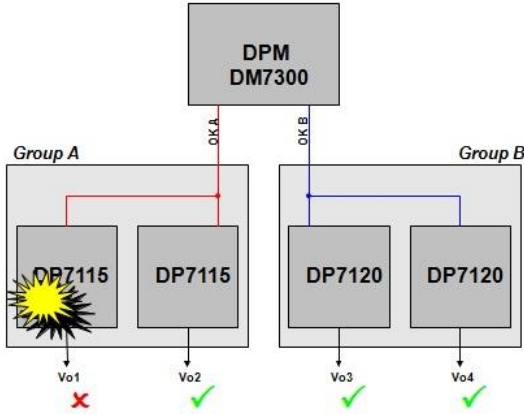

Figure 32. Turn-On into UVP on V3. The UV Fault is programmed to be Non-Latching. Ch1 - Vo1, Ch2 - Vo2 (Group A), Ch3 - Vo3 (Group B). Vo4 not shown.

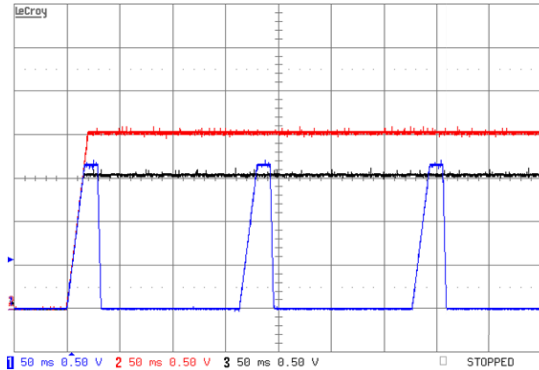

Figure 32 shows a scope capture an actual system when undervoltage error detection is set to not propagate. In this example, the dPOL connected to scope Ch 1 encounters the undervoltage fault after turn-on. Because fault propagation is not enabled for this POL, it alone turns off and generates the UV fault signal. Because a UV fault triggers the sequenced turn-off, the dPOL meets its turn-off delay and falling slew rate settings during the turn-off process as shown in the trace for Ch1. Since the UV fault is programmed to be non-latching, the dPOL will attempt to restart every 130 ms, repeating the process described above until the condition causing the undervoltage is removed. The 130ms hiccup interval is guaranteed regardless of the turn-off delay setting.

The next example is intra-group propagation, the dPOL propagates its fault or error events. Here fault propagation between POLs is enabled. The dPOL powering output Vo1 again encounters an undervoltage error. It pulls its OK line low. Since the dPOL powering output Vo2 (Ch3 in the picture) belongs to the same group (A in this case), pulling down OK-A tells that dPOL to execute a regular turn-off.

Figure 33. Intra Group Fault Propagation

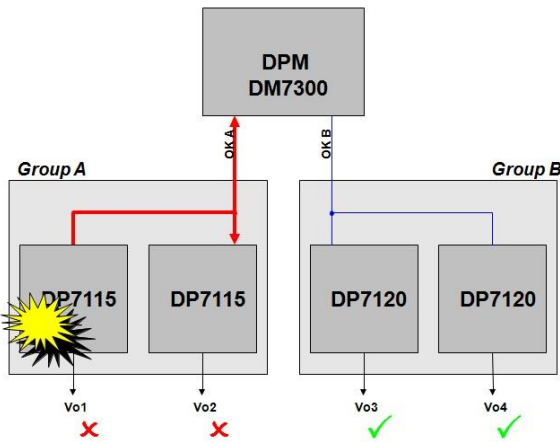
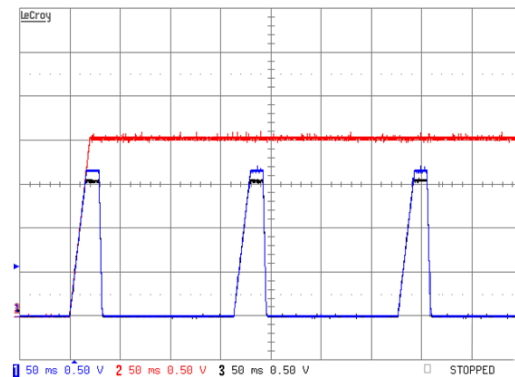

Figure 34. Turn-On into UVP on V3. The UV Fault is programmed to be Non-Latching and Propagate From Group C to Group A. Ch1 - V3(Group c), Ch2 - V2, Ch3 - V1 (Group A)



Since both Vo1 and Vo2 have the same delay and slew rate settings they will continue to turn off and on synchronously every 130ms as shown in Figure 34 until the condition causing the undervoltage is removed. Note that the dPOL powering the output Vo2 (Ch3) actually reaches its voltage set point before the error in Vo1 is detected.

The turn-off type of a POL fault/error as propagated by the faulty dPOL via the OK line is propagated through the DPM to other dPOLs connected to other Groups (per configuration in Figure 29) through its connection to their OK line or lines.

This behavior assures that all dPOLs configured to be affected through Group linkages will switch off with the same turn-off type.

5.5.12. Protection Summary

A summary of protection support, their parameters and features are shown in Table 2.

Table 2. Summary of Protection Parameters and Features

| CODE | NAME | TYPE | WHEN ACTIVE | TURN OFF | LOW SIDE SWITCH | PROPAGATION | DISABLE |
|------|---------------------|---------|--------------------------------|----------|-----------------|-----------------------|---------|
| TW | Temperature Warning | Warning | Whenever V_{IN} is applied | No | N/A | Status Bit | No |
| PG | Power Good | Warning | During steady state | No | N/A | PG | No |
| TR | Tracking | Fault | During ramp up | Fast | Off | Critical | Yes |
| OT | Overtemperature | Fault | Whenever V_{IN} is applied | Regular | Off | Sequenced or Critical | No |
| OC | Overcurrent | Fault | When V_{OUT} exceeds prebias | Fast | Off | Critical | No |
| UV | Undervoltage | Fault | During steady state | Regular | Off | Sequenced or Critical | No |
| OV | Overvoltage | Error | When V_{OUT} exceeds prebias | Fast | On | Critical or Emergency | No |

5.6. OK FAULT AND ERROR CODING

d-pwer® dPOLs have an additional functionality added to the OK line signal. The OK line is used to propagate and receive information from other devices in the power system belonging to the same group as to the kind of turn-off procedure a device has initiated because of a fault.

Figure 35 shows the three types of OK encoding. The bubbles show when the SD and OK line logic levels are sampled by dPOL and DPM logic.

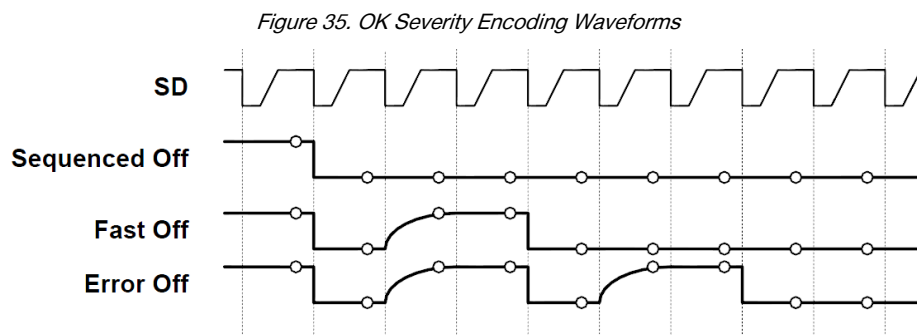

Note that the OK line state changes are always executed by dPOLs at the negative edge of the SD line. The chart shows shut down response types as the user can select the kind of response desired for each type of Fault or Error (within the limits of choice provided for each type of Fault or Error). All dPOL devices in the same Group are expected to trigger the same turn-off procedure in order to maintain overall tracking of output voltages in the system. And when fault propagation is set to go from one group to another, the encoding is passed along un-changed.

5.7. SWITCHING AND COMPENSATION

d-pwer® dPOLs utilize the digital PWM controller. The controller enables users to program most of the performance parameters, such as switching frequency, PWM duty cycle and limiting, interleave and feedback loop compensation.

5.7.1. Switching Frequency

The switching frequency for the DP8160G is fixed at 500 kHz. Although the controller itself will honor selection of other frequencies through direct access via the I²C bus, *this is not recommended*. The GUI only supports the one PWM frequency.

Each dPOL is equipped with a PLL that locks to the 500 KHzSD signal which is generated by the DPM. This sets up for switching actions to be synchronous to the falling edge of SD by all dPOLs, which are thereby kept coordinated to each other.

Although synchronized to SD, switching frequency selection is independent for each dPOL, with the exception of shared load bus groups, where dPOLs attached to a shared load bus are forced to use the same frequency by the GUI.

Figure 36. PWM Controller Window

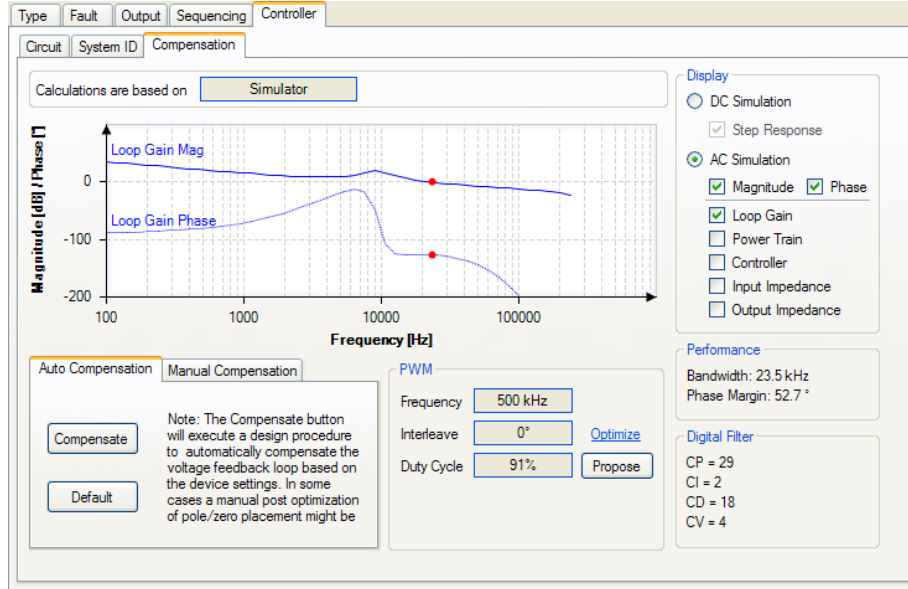

5.7.2. Interleave

Within the same PWM dialog is the switching Interleave control. Interleave is defined as a phase delay between the synchronizing slope of the master clock on the SD pin and the start of each dPOL PWM cycle. This parameter can be programmed in the dPOL Controller Configure Compensation window or directly via the I²C bus by writing into the INT register in 22.5° steps.

Figure 37. Interleave Configuration Register INT

| | | | | | | | |
|---|-------------|------------|-----|-------------|-------------|-------------|-------------|
| INT: Interleave Configuration | | | | | | | |
| Address: 0x04 | | | | | | | |
| R | R | R/W-0 | U | R/W-0 | R/W-0 | R/W-0 | R/W-0 |
| PHS1 | PHS0 | FRQ | --- | INT3 | INT2 | INT1 | INT0 |
| Bit 7 | | | | | | | Bit 0 |
| PHS[1:0]: Phase selection | | | | | | | |
| 0 = Single phase (PWM0) | | | | | | | |
| 1 = Dual phase (PWM0 and PWM2) | | | | | | | |
| 2 = Triple phase (PWM0, PWM1 and PWM2) | | | | | | | |
| 3 = Quad phase (PWM0, PWM1, PWM2 and PWM3) | | | | | | | |
| FRQ: PWM frequency selection | | | | | | | |
| 0 = 500 kHz (default) | | | | | | | |
| 1 = 1000 kHz | | | | | | | |
| Bit 4 Unimplemented: Read as '0' | | | | | | | |
| INT[3:0]: PWM interleave phase with respect to SD line | | | | | | | |
| 0x00 = 0° phase lag | | | | | | | |
| 0x01 = 22.5° phase lag | | | | | | | |
| 0x02 = 45° phase lag | | | | | | | |
| 0x1F = 337.5° phase lag | | | | | | | |

5.7.3. Interleave and Input Bus Noise

When a dPOL turns on its high side switch there is an inrush of current. If no interleave is programmed, inrush current spikes from all dPOLs in the system reflect back into the input source at the same time, adding together as shown in Figure 38.

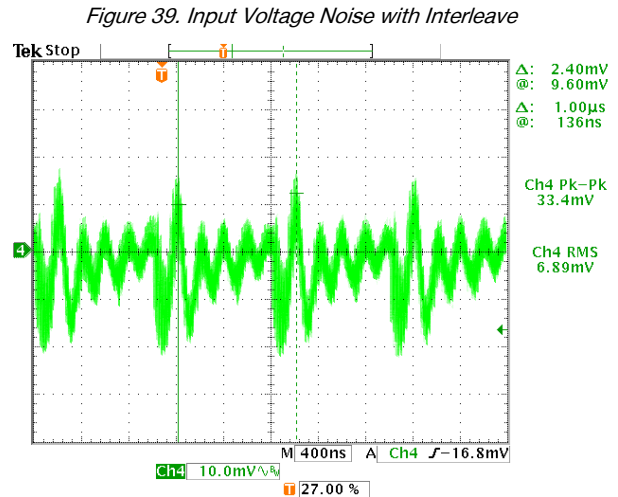
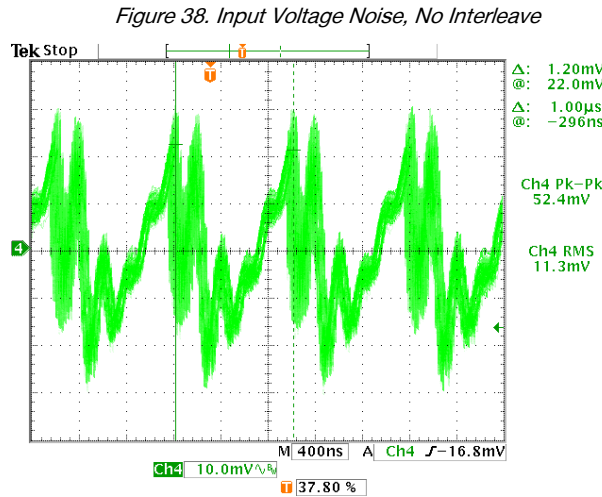
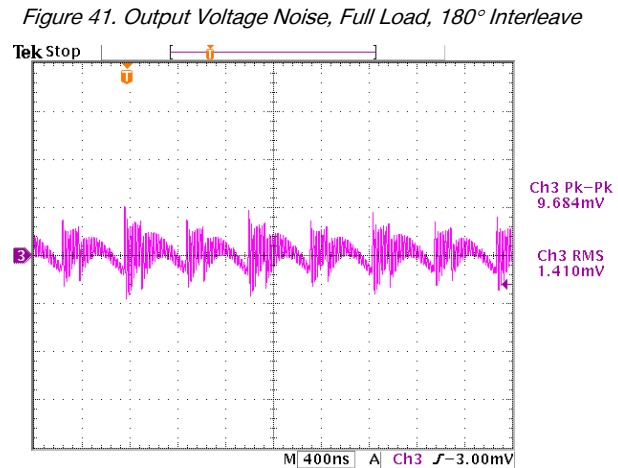
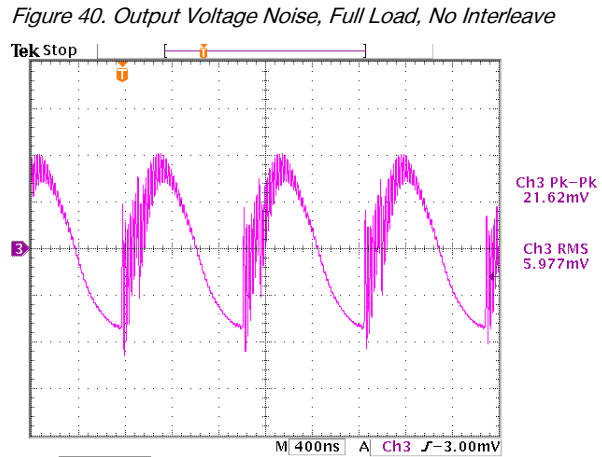

Figure 39 shows the input voltage noise of the three-output system with programmed interleave. Instead of all three dPOLs switching at the same time as in the previous example, the dPOLs V1, V2, and V3 switch at 67.5°, 180°, and 315°, respectively. Noise is spread evenly across the switching cycle resulting in more than 1.5 times reduction. To achieve similar noise reduction without the interleave will require the addition of an external LC filter. Similar noise reduction can be achieved on the output of dPOLs connected in parallel. Figure 40 and Figure 41 show the output noise of two dPOLs connected in parallel without and with a 180° interleave, respectively. Resulting noise reduction is more than 2 times and is equivalent to doubling switching frequency or adding extra capacitance on the output of the dPOLs.



5.7.4. Duty Cycle Limit

The DP8160G is a step-down converter therefore V_{OUT} is always less than V_{IN} . The relationship between the two parameters is characterized by the duty cycle and can be estimated from the following equation:

$$DC = \frac{V_{OUT}}{V_{IN.MN}}$$

Where, DC is the duty cycle, V_{OUT} is the required maximum output voltage (including margining), $V_{IN.MN}$ is the minimum input voltage.

The dPOL controller sets PWM duty cycle higher or lower than the above to compensate for drive train losses or to pull excess charge out of the output filter to keep the output voltage where it is supposed to be.

A side effect of PWM duty cycle is it also sets the rate of change of current into the output filter. A high limit helps deal with transients. However, if this is too high, an overcurrent alarm can be tripped. Thus DC limiting must be a compromise between supplying drive train losses and avoiding nuisance trips from transient load responses.

The duty cycle limit can be programmed in the GUI PWM Controller window Figure 36 or directly via the I²C bus by writing into the DCL register shown in Figure 42. The GUI will supply its own estimate of the best DC limit if the Propose button is clicked.

Figure 42. Duty Cycle Limit Register

| | | | | | | | |
|----------------------------|--|-------------|-------------|-------------|-------------|-----|-------|
| DCL: Duty Cycle Limitation | | | | | | | |
| Address: 0x09 | | | | | | | |
| R/W-1 | R/W-1 | R/W-1 | R/W-0 | R/W-1 | R/W-0 | U | U |
| DCL5 | DCL4 | DCL3 | DCL2 | DCL1 | DCL0 | --- | --- |
| Bit 7 | | | | | | | Bit 0 |
| | DCL[5:0]: Duty Cycle Limitation | | | | | | |
| | 0x00 = 0 | | | | | | |
| | 0x01 = 1/64 | | | | | | |
| Bit 7:2 | 0x02 = 2/64 | | | | | | |
| | ... | | | | | | |
| | 0x1F = 63/64 | | | | | | |
| Bit 1:0 | Unimplemented: Read as '0' | | | | | | |

5.7.5. Feedback Loop Compensation

Programming feedback loop compensation allows optimizing dPOL performance for various application conditions. For example, increase in bandwidth can significantly improve dynamic response.

The dPOL implements a programmable PID (Proportional, Integral, and Derivative) digital controller to shape the open loop transfer function for desired bandwidth and phase/gain margin.

Feedback loop compensation can be programmed in the GUI PWM Controller window by setting Kr (Proportional), Ti (Integral), Td (Derivative), and Tv (Derivative roll-off) parameters or directly writing into the respective registers (CP, CI, CD, B1). Note that the coefficient Kr and the timing parameters (Ti, Td, Tv) displayed in the GUI do not map directly to the register values. It is therefore strongly recommended to use only the GUI to set the compensation values.

The GUI offers 3 ways to compensate the feedback loop:

Auto-Compensation: The GUI will calculate compensation settings from either information entered as to output capacitors in the application circuit, or, if the SysID function has been run, the frequency response measured through the SysID function in the target dPOL. This method is usually sufficient, but is sensitive to accurate accounting of capacitor values and esr. The GUI displays the results of running Auto-Compensation as a set of graphs and compensation values.

Manual Compensation: The GUI supports manually adjusting feedback compensation parameters. As the parameters are changed the GUI recalculates expected frequency and phase performance.

System Identification (SysID) and Auto-Compensation: Hardware built into the dPOL controller that injects pseudo random bit sequence (PRBS) noise into PWM calculations and observes the response of the output voltage. The GUI collects this data and calculates actual system frequency response. Having frequency response data allows the Auto-Compensation function to have a better idea of actual output filter characteristics when it calculates feedback coefficients.

Using noise to plumb the output filter requires current values for compensation be good enough that injected signal can be extracted from system noise and the added noise does not trip a fault or error response. A moderately workable solution for compensation must be obtained by calculating from assumed system component values before invoking SysID.



5.8. TRANSIENT RESPONSE

The following figures show the deviation of the output voltage in response to alternating 25 and 75 % step loads applied at 2.5A/ μ s. The dPOL converter is switching at 500 KHz and has 10 x 22 μ F ceramic capacitors connected across the output pins. Bandwidth of the feedback loop was optimized for slightly overdamped response.

Figure 43. Transient Response with Regulation set to 0.0 mV/A

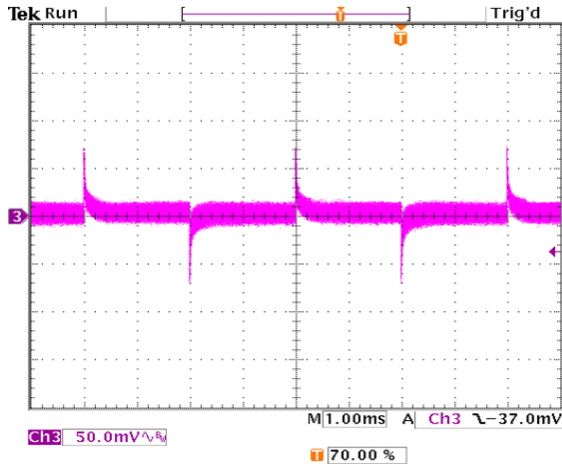
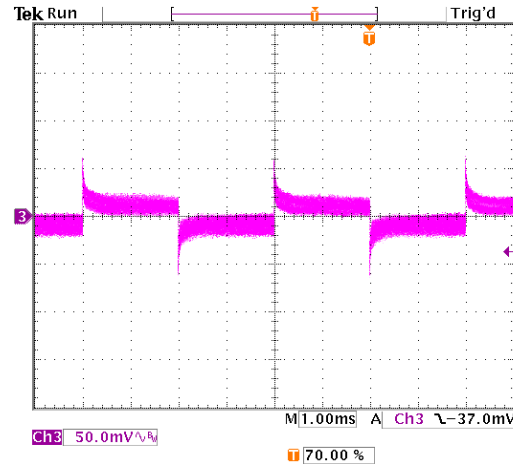

Figure 44. Transient Response with Regulation set to 3.72mV/A



As noted earlier, increasing the Load Regulation parameter provides load dependant dynamic load positioning. This shows up in Figure 44.

5.9. LOAD CURRENT SHARING

The DP8160G is equipped with a patented active digital current share function. Setting up for current sharing requires both hardware and software configuration actions.

To set up for the current sharing, interconnect the CS pins of the dPOLs that are to share the load in parallel. This pulse width modulated digital signal drives the output currents of all dPOLs to approximately the same level (the dominant, or master dPOL will tend to carry slightly more of the load than the others).

In addition to the CS interconnection, the DPM must be informed of the sharing configuration. This is done in the **DPM / Configure / Devices** window shown in Figure 46. Just to the right of each dPOL address, set the spin control to one of 10 possible sharing busses (the number is an accounting aid for firmware.)

The GUI automatically copies common parameters changed in one dPOL's setup information into all dPOLs connected to the parallel bus. Some parameters, such as load sharing, must be set independently.

5.9.1. CS and Regulation

Load Regulation is an important part of setting up two or more dPOLs to share load. The dPOL designated the "master" should have a lower Load Regulation setting than the other dPOL(s) connected to its sharing bus.

In operation, the negative CS duty cycle in each dPOL is proportional to the unit's load current. As the loading goes up, the negative period gets wider. A dPOL which sees CS duty greater than its internally calculated value will increase its output voltage to increase its load share.

Non-zero regulation, on the other hand, tends to lower output voltage as loading increases. It also tends to retard the calculated CS period. The effect of these two actions, regulation and CS tracking, cause the dPOL or dPOLs with higher regulation values to track the loading of the dPOL with a lower regulation value. The Load Regulation setting insures the master will carry a slightly higher share of the common load.

Load Regulation is set in the **Device / Configure / Output** dialog as noted earlier. Best sharing is done when the slave devices have two to three steps higher Load Regulation values. Less and sharing is slightly unstable (ripple noise increases), more regulation and sharing becomes much less equal. Note that the GUI does not automatically bump

up regulation for dPOLs attached to the same regulation bus. This must be done by hand. Also, it is recommended that the dPOL closest to the biggest load element on the shared output bus be set up to act as the group's master.

5.9.2. CS and Interleave

Since shared busses tend to have relatively high currents, interleaving switching of shared bus dPOLs is generally desirable. The lowest noise generation is usually achieved when shared bus dPOL interleave phasing is set to approximately equally spaced intervals.

5.10. MONITORING

Along with status information, dPOL converters can monitor their own performance parameters such as output voltage, output current, and temperature.

The output voltage is measured at the output sense pins, output current is measured using the ESR of the output inductor and temperature is measured by the thermal sensor built into the controller IC. Output current readings are adjusted based on temperature readings to compensate for the change of ESR of the inductor with temperature.

A 12-Bit Analog to Digital Converter (ADC) converts the output voltage, output current, and temperature into a digital signal to be transmitted via the serial interface (12Bits for the Voltage, 8 Bits for the Current and Temperature).

Monitored parameters are stored in registers (VOM, IOM, and TMON) that are continuously updated in the DPM at a fixed refresh rate of 1sec. These monitoring values can be accessed via the I²C interface with high and low level commands as described in the "DPM Programming Manual".

Shown in Figure 45 is a capture of the GUI System Monitor while operating the ZM7300 Evaluation board.

5.10.1. In System Monitoring

In system parametric and status monitoring is implemented through the I²C interface. The appropriate protocols are covered in the ZM7300 DPM Programming Manual. The GUI uses the published commands.

In writing software for I²C bus transactions, it is important to note that I²C responses are lower in priority in DPM operation than SD bus transactions. If an I²C transaction overlaps an SD bus transaction, the DPM will put the I²C bus on "hold" until it completes its SD activity. The GUI is aware of this and such delays are transparent.

When directly polling dPOLs for information, setting I²C bus timeouts too low can cause hangups where the DPM is waiting for the I²C master to complete a transaction and the master has timed out. To avoid such timeout related problems, set I²C interface timeout to greater than the time required for polling all dPOLs, or 150ms (whichever is greater). See the programming manual referenced above for the equation used to calculated worst case polling duration.

Figure 45 DPM Monitoring Window

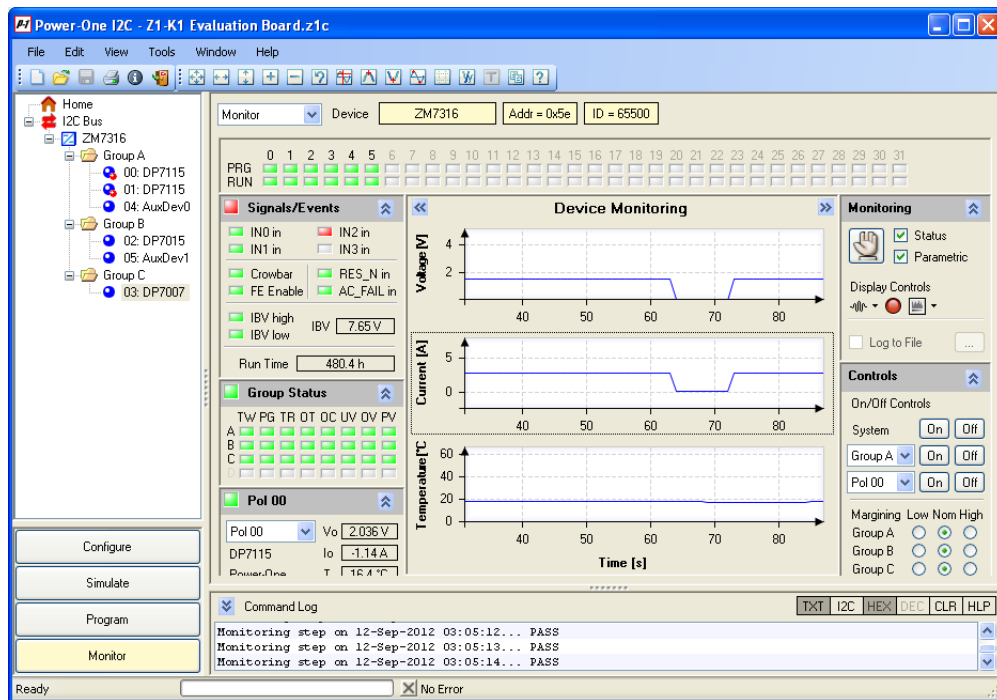

6. ADDING DPOLS TO A SYSTEM

dPOL converters are added to a d-pwer® system through the DPM Configuration/Devices dialog. Clicking on an empty address location brings up a menu which allows specifying which POL type is needed. Below is an example using all of the DP7000 series devices currently offered.

Note that Auto-On, P-Monitor and S-Monitor options are only configurable by Group, and not by individual dPOL configuration. These options affect only DPM behavior. Enabling them does not burden a dPOL.

Auto-On sets a group to turn on once all IBV power is available and dPOLs are configured. This defaults to enabled.

P-Monitor enables periodic query of Vout, Iout and Temp values from each dPOL in the group where it is enabled (dPOLs will always measure these parameters in an ongoing basis even if Vout is not enabled).

S-Monitor enables periodic query of POL Status. While a DPM will always be able to detect a low OK condition, it requires this option enabled for Monitor function to query status registers.

Figure 46 Evaluation board Configuration Window showing Shared Bus Assignment

The screenshot shows the configuration window for the Power-One I2C - Z1-K1 Evaluation Board. The main configuration area is titled 'Configure' and shows the device 'ZM7316' with address '0x5e' and ID '65500'. The 'Devices' tab is active, showing a table of parameters for four dPOLs (Pol 00 to Pol 04). The 'Parallel Bus' dropdown is set to 'BUS1'. The 'Command Log' at the bottom shows three monitoring steps, all of which passed.

| Parameter | Pol 00 | Pol 01 | Pol 02 | Pol 03 | Pol 04 |
|--------------------|--------------|--------------|--------------|--------------|---------|
| Addr | 00 | 01 | 02 | 03 | 04 |
| Name | DP7115 | DP7115 | DP7015 | DP7007 | AuxDev0 |
| Alias | DP7115 | DP7115 | DP7015 | DP7007 | AuxDev0 |
| Vendor | Power-One | Power-One | Power-One | Power-One | |
| Package Size | 22.2 x 12... | 22.2 x 12... | 22.2 x 12... | 22.2 x 12... | |
| Output Voltage | 2.035 V | 2.035 V | 1.85 V | 1.52 V | |
| Current Limit | 19.8 A | 19.8 A | 19.8 A | 9.2 A | |
| Load Regulation | 0.0 mV/A | 1.61 mV/A | 0.0 mV/A | 0.0 mV/A | |
| Margining High [%] | 5% | 5% | 5% | 5% | |
| Margining Low [%] | -6% | -6% | -7% | -6% | |
| Under-Voltage [%] | 75% | 75% | 75% | 75% | |
| Power Good Low... | 90% | 90% | 90% | 90% | |
| Power Good Hig... | 110% | 110% | 110% | 110% | |
| Over-Voltage [%] | 130% | 130% | 130% | 130% | |
| Turn-On Delay | 20 ms | 20 ms | 0 ms | 20 ms | 0 ms |
| Turn-Off Delay | 15 ms | 15 ms | 13 ms | 11 ms | 10 ms |
| Rising Slew Rate | 0.20 V/ms | 0.20 V/ms | 0.20 V/ms | 0.20 V/ms | |
| Falling Slew Rate | -0.50 V/ms | -0.50 V/ms | -0.50 V/ms | -0.50 V/ms | |
| Zero1 | | | | | |
| Zero2 | | | | | |
| Pole1 | | | | | |
| Pole2 | | | | | |
| Pole3 | | | | | |
| PwM Frequency | 500 kHz | 500 kHz | 500 kHz | 500 kHz | |
| Interleave | 0° | 0° | 0° | 0° | |
| ADC High | | | | | |
| ADC Low | | | | | |

7. TESTING FAULT AND ERROR RESPONSE

Included in the architecture of d-pwer® dPOLs is a mechanism for simulating errors and faults. This allows the designer to test their response configuration without actually needing to induce the fault.

The GUI supports this feature in the Monitor window when monitoring is active (See Figure 47). When monitoring is off, the Fault Injection control boxes are disabled and grayed out.

Figure 47. Fault Injection Controls In Monitor Window

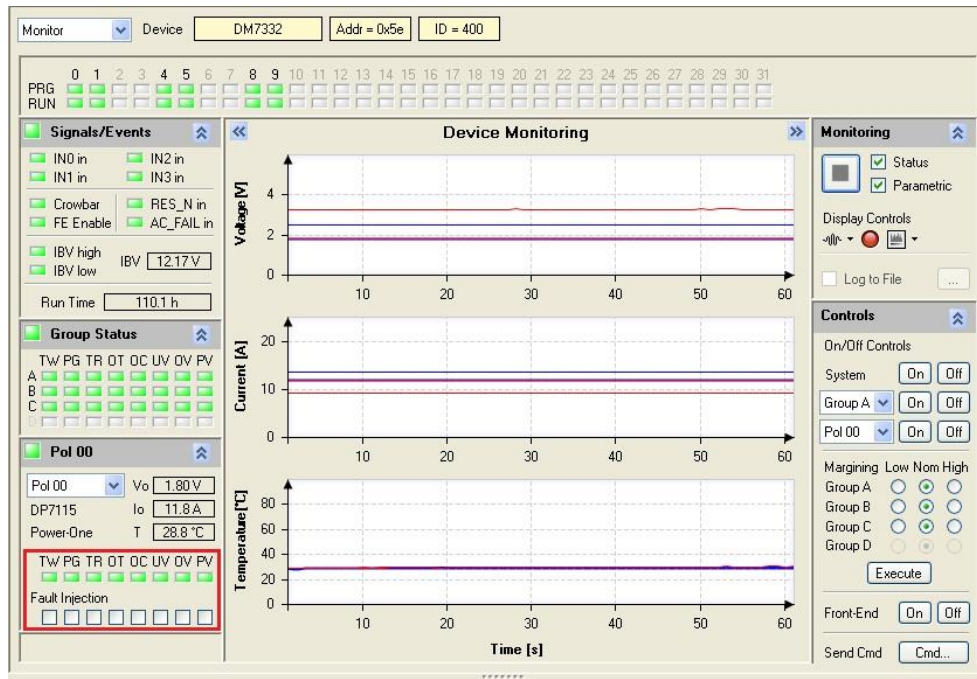

Fault injection into a dPOL requires selecting that dPOL in the POL status dialog in the left column of the Monitoring dialog window. As long as the checkbox is checked, the fault trigger is present in the dPOL. An injected fault is handled by the dPOL in the same fashion as an actual fault. It therefore gets propagated to the other dPOLs / Groups and shuts down in the programmed way the dPOL/Group/System as programmed for that fault.

Figure 48. Example Overtemp Fault Injection in the GUI

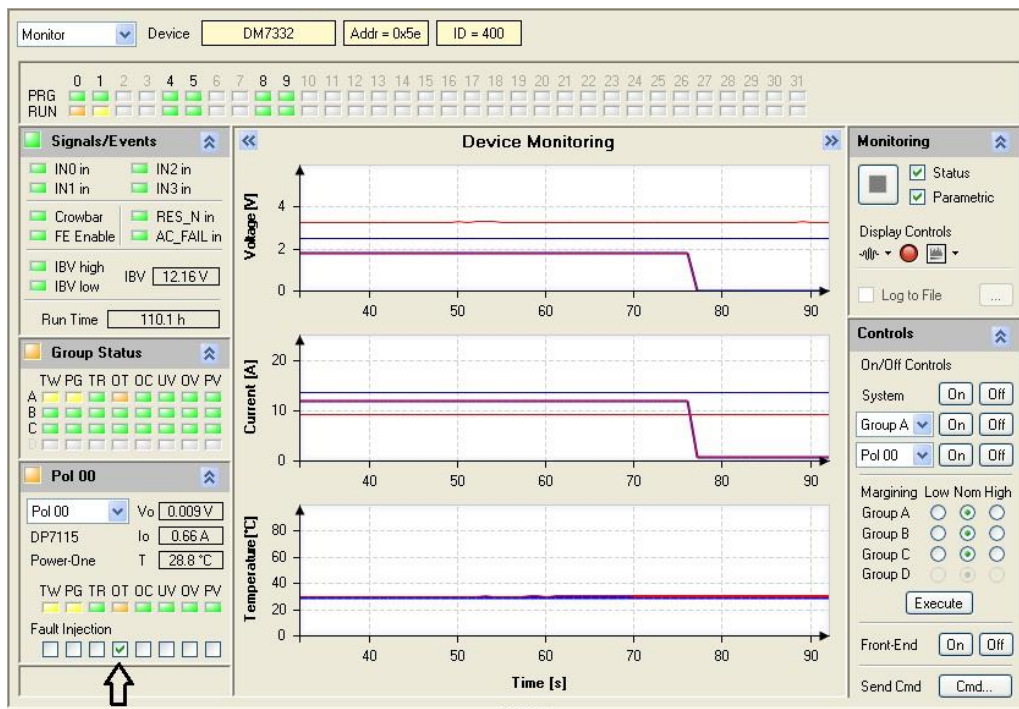

In Figure 48 we see the effects of injecting an Overtemp (OT) fault. Note that dPOL-0 shows an OT fault. dPOL-0 and -1 are in the same Group and fault propagation for the dPOL is to propagate to the group. dPOL -4 and above are in Groups B and C. Propagation is not enabled from Group A to B.

The OT fault shows up as an orange indicator in the dPOL and RUN status LEDs. Group LEDs show yellow, indicating all of the members of the group have shut down.

Fault recovery depends whether the fault is a latching or non-latching fault:

A non-latching fault is cleared by unchecking the checkbox (clears the fault trigger). The dPOL will re-start after the 130ms time out of non-latching faults (hiccup time) (Group and System follows restart).

Latching faults clear in one of two ways. The first method is to clear the fault trigger (uncheck the checkbox) (note: the dPOL remains off since the fault is latching).

Alternately, a latched fault can be cleared by toggling the EN pin or by commanding the dPOL to turn-off and turn-off again via the GUI interface (obviously more convenient). Therefore, once the fault trigger is cleared, click the "Off" button of the dPOL or Group (clears the fault, status LEDs turn back to green) and then the "On" button of the dPOL or Group to re-enable it.

8. TYPICAL APPLICATION

Shown in Figure 49 is a block diagram of a multiple dPOL power system. The key interconnections needed between the DPM and the dPOLs are Intermediate Voltage Bus (IBV), SD, OK (A - D), and, between the first two dPOLs which share a bus load, their CS connections. Each dPOL has its own output bulk filter capacitors. This illustrates how simple a dPOL based system is to implement in hardware. SD provides synchronization of all dPOLs as well as communication. PG, not shown, is optional, though this is usually used with auxiliary power supplies that are not digitally controlled.

Figure 49. Multi-dPOL Power System Diagram

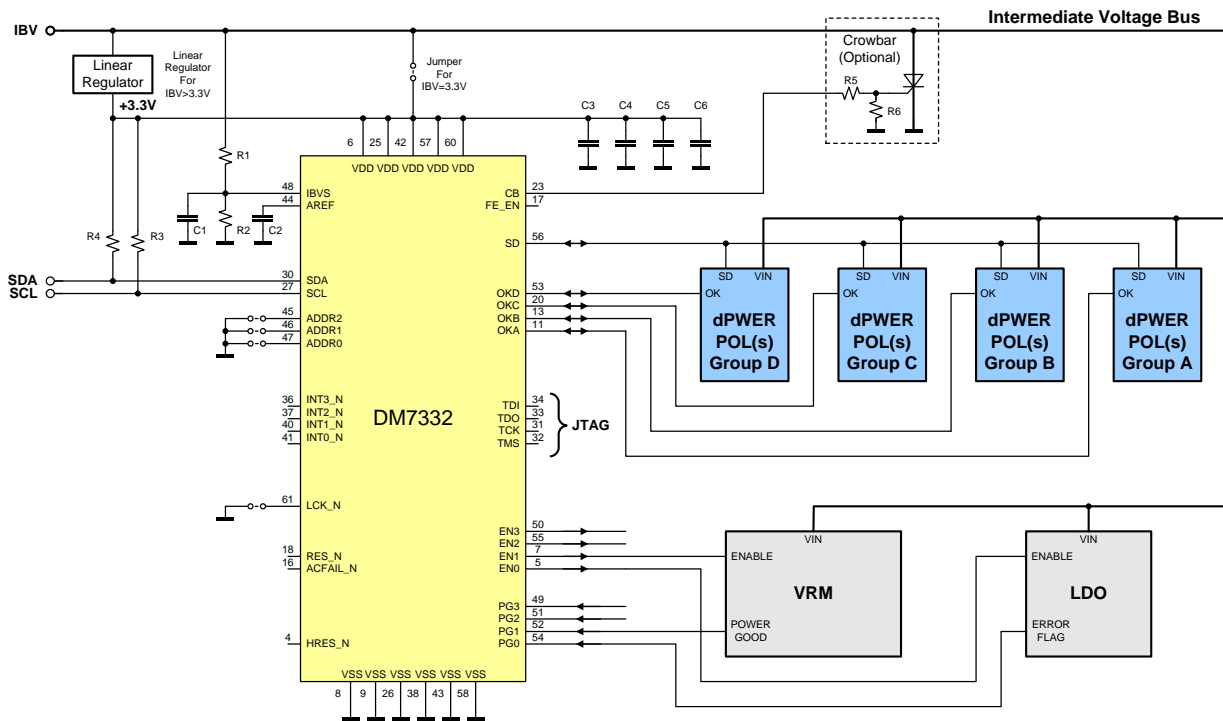

Shown in Figure 50 is a schematic of a typical application using at least one DP8160G dPOL (although additional DP8160G or other d-pwer® series dPOLs (Note SD and OK dashed lines "TO OTHER dPOLs") may be connected.

The SD line provides synchronization of all dPOLs to the master clock generated by the DPM and simultaneously performs data transfer between dPOLs and the DPM. Each dPOL has a unique 5-bit address programmed by grounding respective address pins. To enable the current sharing, CS pins of dPOLs connected in parallel are interconnected.

In addition to the SD line, the DP8160G is connected to OK-A. Any other dPOLs added should connect their OK pins to the OK pins of the DPM associated with their respective Group assignments.

The type, value, and the number of output capacitors shown in the schematic are required to meet the specifications published in the data sheet. However, all d-pwer® dPOLs are fully operational with different configurations of output capacitors. The feedback loop compensation may need to be adjusted to optimize performance of the dPOLs for specific parameters of the output capacitors.

The supervisory reset circuit in the above diagram, U2, is recommended for systems where the 3.3V supply to the DPM does not turn on faster than 0.5 V/ms.

Note: The DP8160G is footprint compatible with the ZY8160—No change in PCB is needed to upgrade to d-pwer® parts. However, configuration data must be altered through the I²C GUI and programmed into the DPM. When upgrading to d-pwer®, *mixing ZY and DP series devices is not recommended. All parts must be upgraded.*

Figure 50. Block Diagram of Typical Multiple Output Application with Digital Power Manager and I2C Interface

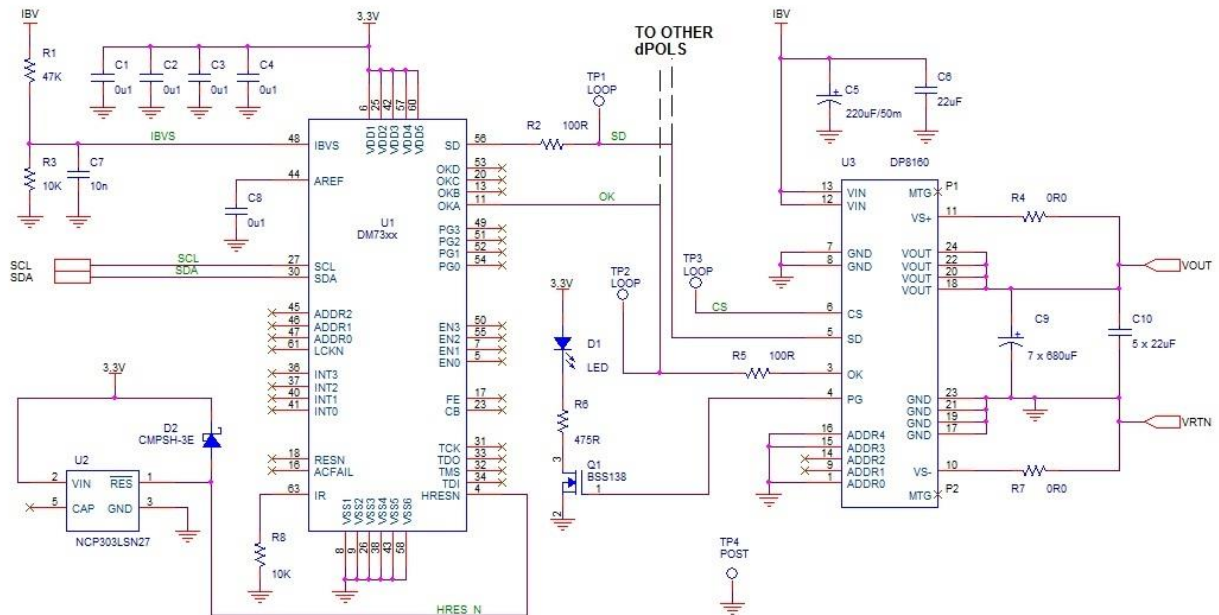

9. SAFETY

The DP8160G dPOL converters **do not provide isolation** from input to output. The input devices powering DP8160G must provide relevant isolation requirements according to all IEC60950 based standards. Nevertheless, if the system using the converter needs to receive safety agency approval, certain rules must be followed in the design of the system. In particular, all of the creepage and clearance requirements of the end-use safety requirements must be observed. These requirements are included in UL60950 - CSA60950-00 and EN60950, although specific applications may have other or additional requirements.

The DP8160G dPOL converters have no internal fuse. If required, the external fuse needs to be provided to protect the converter from catastrophic failure. Refer to the “Input Fuse Selection for DC/DC converters” application note on www.belpowersolutions.com for proper selection of the input fuse. Both input traces and the chassis ground trace (if applicable) must be capable of conducting a current of 1.5 times the value of the fuse without opening. The fuse must not be placed in the grounded input line.

Abnormal and component failure tests were conducted with the dPOL input protected by a fast-acting 32V, 25A fuse. If a fuse rated greater than 25A is used, additional testing may be required.

In order for the output of the DP8160G dPOL converter to be considered as SELV (Safety Extra Low Voltage), according to all IEC60950 based standards, the input to the dPOL needs to be supplied by an isolated secondary source providing a SELV also.

10. ENVIRONMENTAL

| PARAMETER | CONDITIONS / DESCRIPTION | MIN | NOM | MAX | UNITS |
|---|--|------|----------------|-----|---------|
| Ambient Temperature Range | | -40 | | 85 | °C |
| Storage Temperature (Ts) | | -50 | | 125 | °C |
| Operating Vibration (sinusoidal) | Frequency Range | 5 | | 500 | Hz |
| | Magnitude | 0.5 | | | G |
| | Sweep Rate | 1 | | | oct/min |
| | Repetitions in each axis (Min-Max-Min Sweep) | 2 | | | sweeps |
| Non-Operating Shock (half sine) | Acceleration | 50 | | | G |
| | Duration | 11 | | | ms |
| | Number of shocks in each axis | 10 | | | |
| MTBF | Calculated Per Telcordia Technologies SR-332 | 18.5 | | | |
| Peak Reflow Temperature | DP8160G | | 245 | 260 | |
| Lead Plating | DP8160G | | 100% Matte Tin | | |
| Moisture Sensitivity Level per JEDEC J-STD-020C | DP8160G | | 1 | | |

11. MECHANICAL DRAWINGS

| PARAMETER | CONDITIONS / DESCRIPTION | MAX | UNITS |
|------------|--------------------------|-------|-------|
| Dimensions | Width | 61.21 | |
| | Height | 31.92 | mm |
| | Depth | 14.40 | |
| Weight | | 33 | g |

Figure 51 - Mechanical Drawing

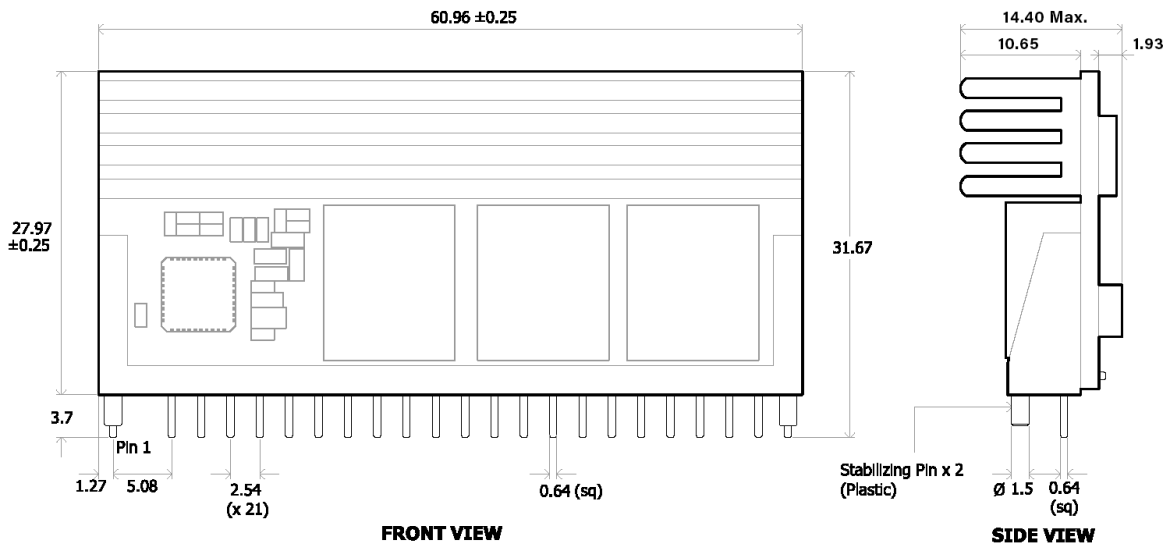
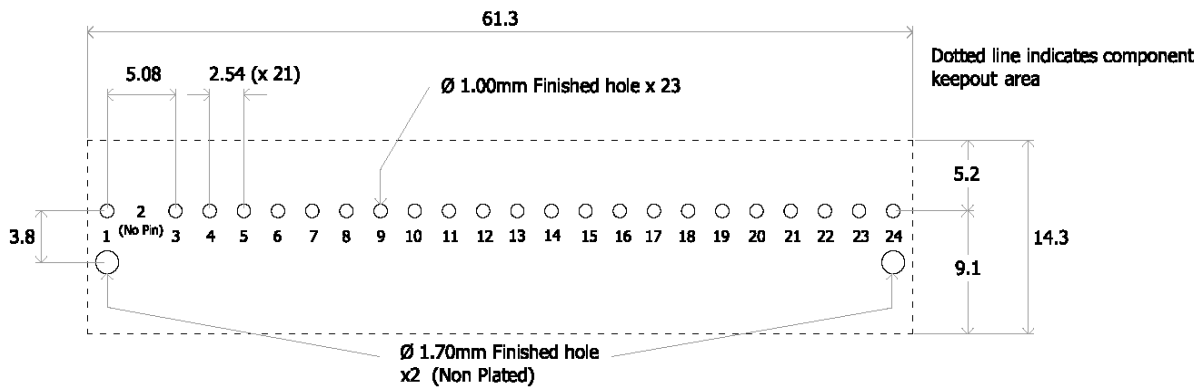

Figure 52 - Recommended Footprint – Top View



Note: I²C is a trademark of Philips Corporation.

12. ORDERING INFORMATION

| DP | 81 | 60 | G | - | zz |
|----------------|----------------------------|----------------|---|------|--|
| Product Family | Series | Output Current | RoHS Compliance | Dash | Packaging Option ⁹ |
| d-pwer® | Intelligent dPOL Converter | 60 A | G - RoHS compliant for all six substances | | T050 - 50pc Tray Sample quantity orders have no suffix. |

Example:

DP8160G-T050: A 50-piece tray of RoHS compliant dPOL converters. Each dPOL converter is labelled DP8160G.

Reference Documents

- DM7300 Digital Power Manager Data Sheet
- DM7300 Digital Power Manager Programming Manual
- I²C Graphical User Interface
- DM00056-KIT USB to I²C Adapter Kit. User Manual

For more information on these products consult: tech.support@psbel.com

NUCLEAR AND MEDICAL APPLICATIONS - Products are not designed or intended for use as critical components in life support systems, equipment used in hazardous environments, or nuclear control systems.

TECHNICAL REVISIONS - The appearance of products, including safety agency certifications pictured on labels, may change depending on the date manufactured. Specifications are subject to change without notice.

⁹ Packaging option is used only for ordering and not included in the part number printed on the dPOL converter label.