

# IS31AP4912 STEREO HEADPHONE DRIVER EVALUATION BOARD GUIDE

## DESCRIPTION

The IS31AP4912 is stereo headphone drivers designed to allow the removal of the output DC-blocking capacitors for reduced component count and cost. The IS31AP4912 is ideal for small portable electronics where size and cost are critical design parameters.

## FEATURES

- No output DC-blocking capacitors
- Supply voltage range from 2.7V to 5.5V
- Low output noise (7 $\mu$ V)
- High SNR (103dB)
- -95dB PSRR
- Thermal protect circuit
- Integrated click-and-pop suppression circuitry
- UTQFN-12 (2mm  $\times$  2mm) package

## QUICK START

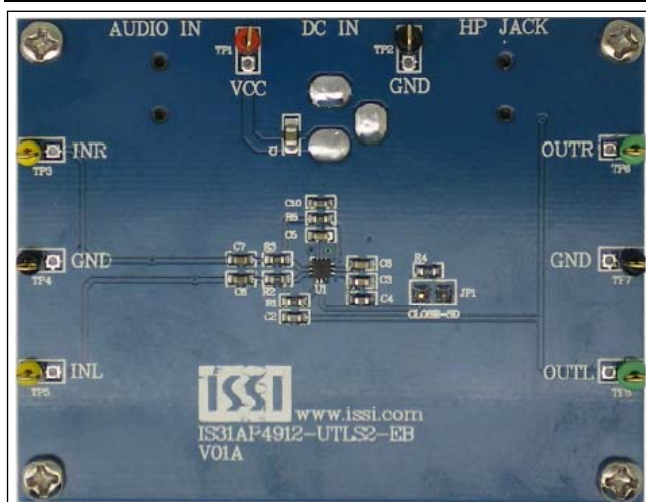

Figure 1: Photo of IS31AP4912 Evaluation Board

## RECOMMENDED EQUIPMENT

- 5.0V, 2A power supply
- Audio source (i.e. MP3 player, Notebook PC, etc.)
- Headphone (32 $\Omega$ )

## ABSOLUTE MAXIMUM RATINGS

- $\leq$  5.5V power supply

**Caution:** Do not exceed the conditions listed above; otherwise the board will be damaged.

## PROCEDURE

The IS31AP4912 Evaluation board is fully assembled and tested. Follow the steps listed below to verify board operation.

**Caution:** Do not turn on the power supply until all connections are completed.

- 1) Connect headphone (32 $\Omega$ ) to the connector (HP Jack).
- 2) Connect the ground terminal of the power supply to the GND and the positive terminal to the VCC. Or connect DC power to connector (DC IN).
- 3) Connect the audio sources to the INR terminal (right channel) and INL terminal (left channel); or connect audio sources to the connector (AUDIO IN).
- 4) Turn on the power supply, and pay attention to the supply current. If the current exceeds 200mA, please check for circuit fault.
- 5) Turn on the audio sources.

## ORDERING INFORMATION

Part No.	Temperature Range	Package
IS31AP4912-UTLS2-EB	-40°C to +85°C (Industrial)	UTQFN-12, Lead-free

Table 1: Ordering Information

For pricing, delivery, and ordering information, please contacts Lumissil's analog marketing team at [analog@Lumissil.com](mailto:analog@Lumissil.com) or (408) 969-6600.

# IS31AP4912 STEREO HEADPHONE DRIVER EVALUATION BOARD GUIDE

## GAIN SETTING

The input resistors  $R_{IN}$  (R2, R3) and feedback resistors  $R_F$  (R1, R5) set the gain of the amplifier according to Equation (1).

$$Gain = \frac{R_F}{R_{IN}} \left( \frac{V}{V} \right) \quad (1)$$

*Note: Please refer to the datasheet to get more information about IS31AP4912.*

## HIGH PASS FILTER

The input capacitors (C6, C7) and input resistors (R2, R3) form a high pass filter with the corner frequency,  $f_c$ , determined in Equation (2).

$$f_c = \frac{1}{2\pi R_{IN} C_{IN}} \quad (2)$$

## SHUTDOWN MODE

Close Jumper (JP1) enter shutdown mode.

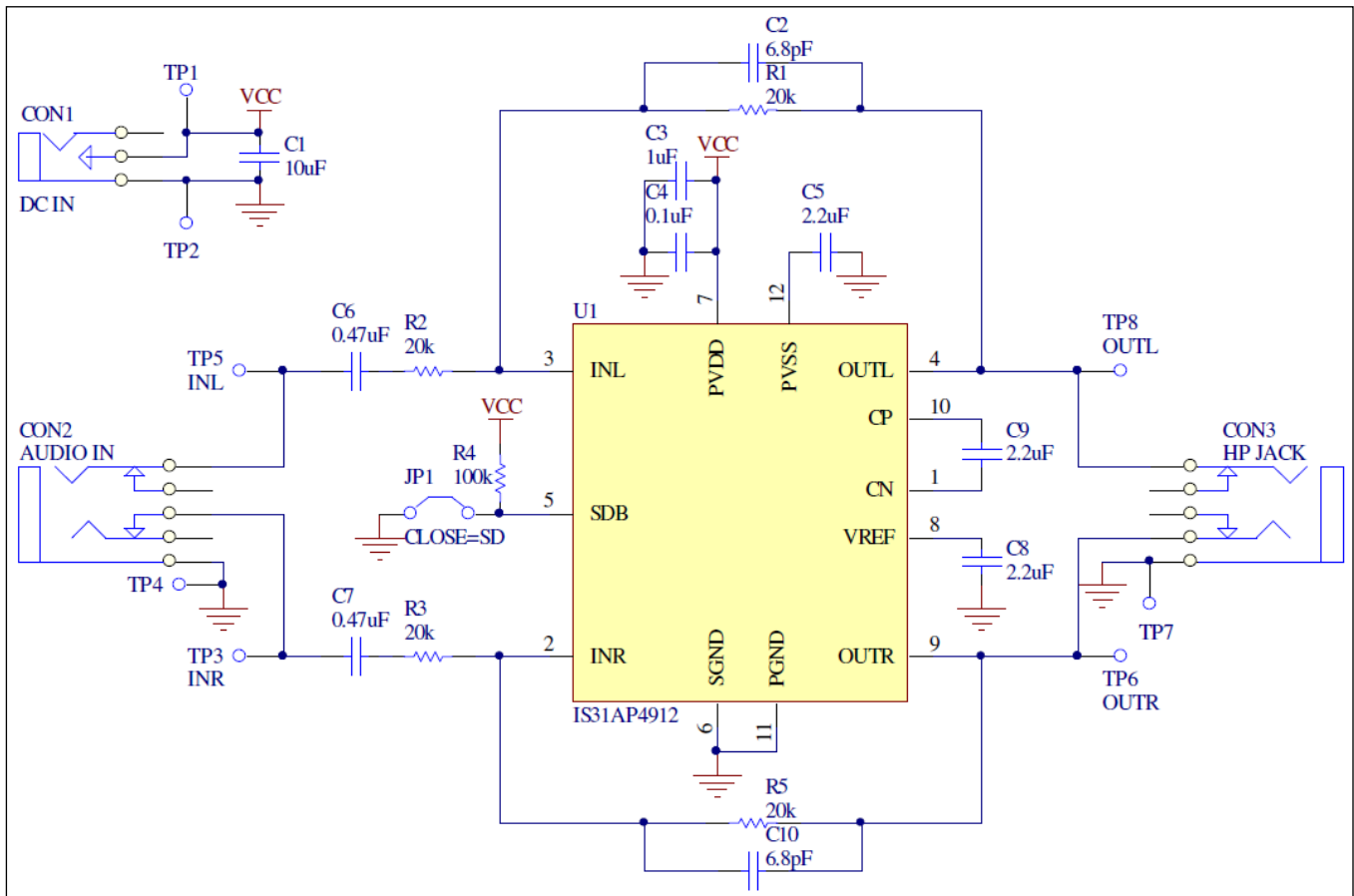

Figure 2: IS31AP4912 Application Schematic

# IS31AP4912 STEREO HEADPHONE DRIVER EVALUATION BOARD GUIDE



## BILL OF MATERIALS

Name	Symbol	Description	Qty	Supplier	Part No.
Audio Amplifier	U1	Stereo Headphone Driver	1	Lumissil	IS31AP4912
Resistor	R1,R2,R3,R5	RES,20k,1/16W,±5%,SMD	4		
Resistor	R4	RES,100k,1/16W,±5%,SMD	1		
Capacitor	C1	CAP,10µF,16V,±20%,SMD	1		
Capacitor	C2,C10	CAP,6.8pF,16V,±20%,SMD	2		
Capacitor	C3	CAP,1µF,16V,±20%,SMD	1		
Capacitor	C4	CAP,0.1µF,16V,±20%,SMD	1		
Capacitor	C5,C8,C9	CAP,2.2µF,16V,±20%,SMD	3		
Capacitor	C6,C7	CAP,0.47µF,16V,±20%,SMD	2		

*Bill of Materials, refer to Figure 2 above.*

# IS31AP4912 STEREO HEADPHONE DRIVER EVALUATION BOARD GUIDE

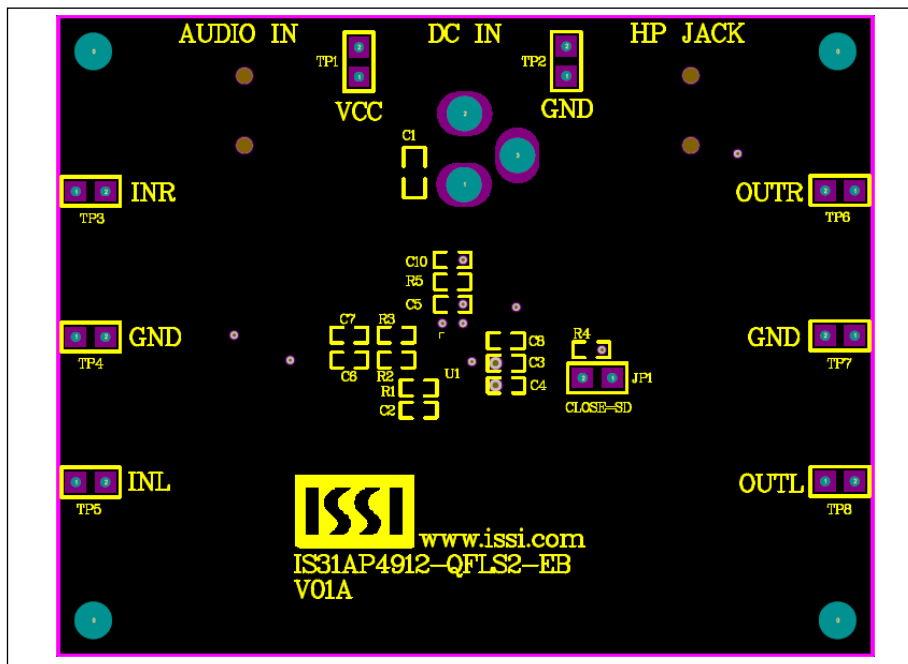

Figure 3: Board Component Placement Guide - Top Layer

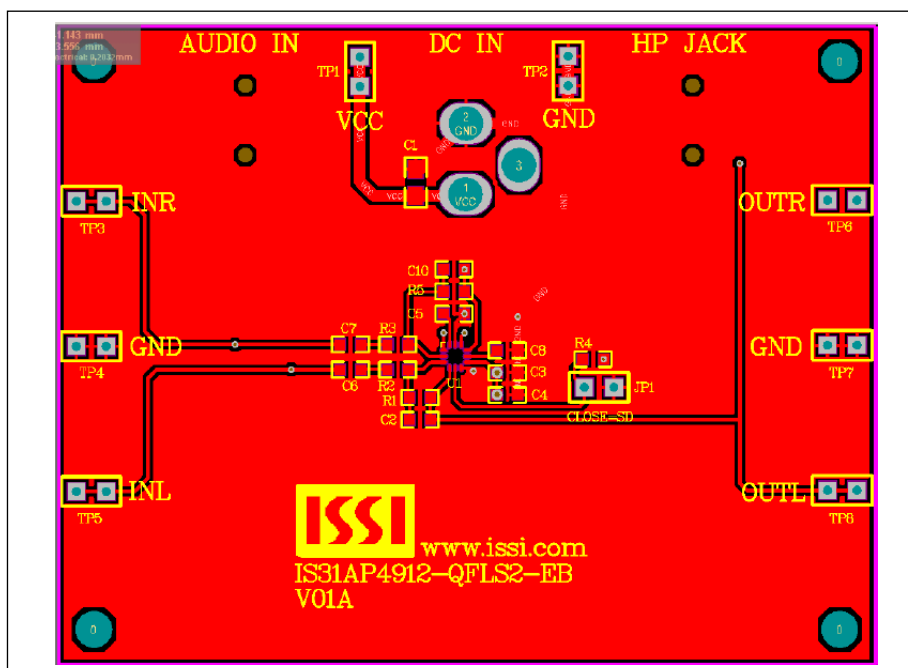
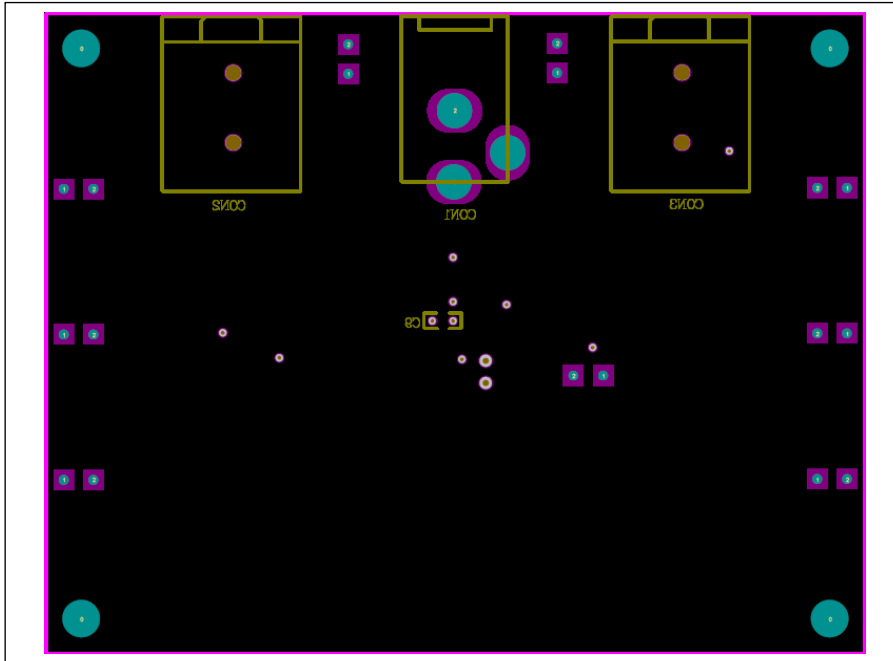
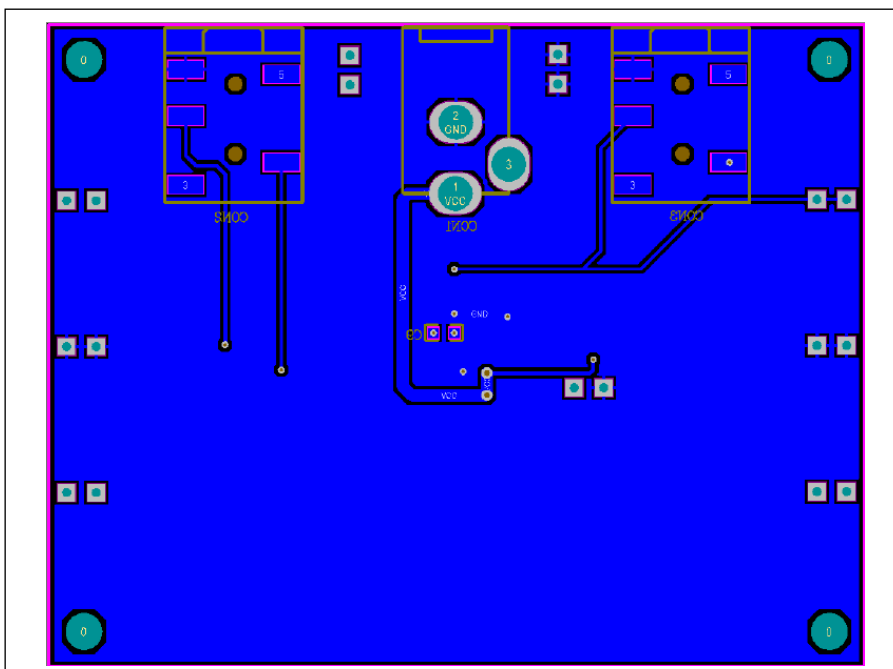

Figure 4: Board PCB Layout - Top Layer



**Figure 5: Board Component Placement Guide - Bottom Layer**



**Figure 6: Board PCB Layout - Bottom Layer**

Copyright © 2013 Lumissil Microsystems. All rights reserved. Lumissil Microsystems reserves the right to make changes to this specification and its products at any time without notice. Lumissil Microsystems assumes no liability arising out of the application or use of any information, products or services described herein. Customers are advised to obtain the latest version of this device specification before relying on any published information and before placing orders for products.

Lumissil Microsystems does not recommend the use of any of its products in life support applications where the failure or malfunction of the product can reasonably be expected to cause failure of the life support system or to significantly affect its safety or effectiveness. Products are not authorized for use in such applications unless Lumissil Microsystems receives written assurance to its satisfaction, that:

- a.) the risk of injury or damage has been minimized;
- b.) the user assume all such risks; and
- c.) potential liability of Lumissil Microsystems is adequately protected under the circumstances

# Mouser Electronics

Authorized Distributor

Click to View Pricing, Inventory, Delivery & Lifecycle Information:

ISSI:

[IS31AP4912-UTLS2-EB](#)