

DESCRIPTION

This M63022FP is 1 chip driver IC for spindle motor and 5 channel actuators. All of the motor and actuator of optical disk drive system (CD-ROM etc.) can be driven by only this IC.

This IC has a direct PWM control system for Spindle and Slide channels drive due to reducing IC power dissipation.

This IC has three voltage supply terminals (for Spindle, Slide, Focus/Tracking and Loading) , and three voltage supply can be set separately.

Further more this IC has short braking select function, FG amplifier, thermal shut down circuit, standby circuit, reverse rotation detect circuit.

APPLICATION

CD-ROM, DVD, DVD-ROM, DVD-RAM ,Optical disc related system, etc

PIN CONFIGURATION (TOP VIEW)

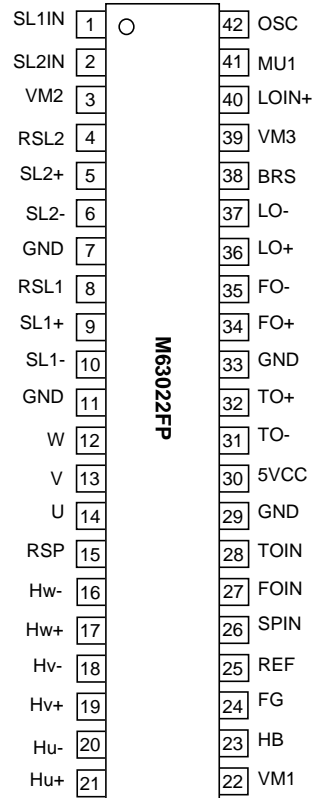

Outline 42P9R-K/B

BLOCK DIAGRAM

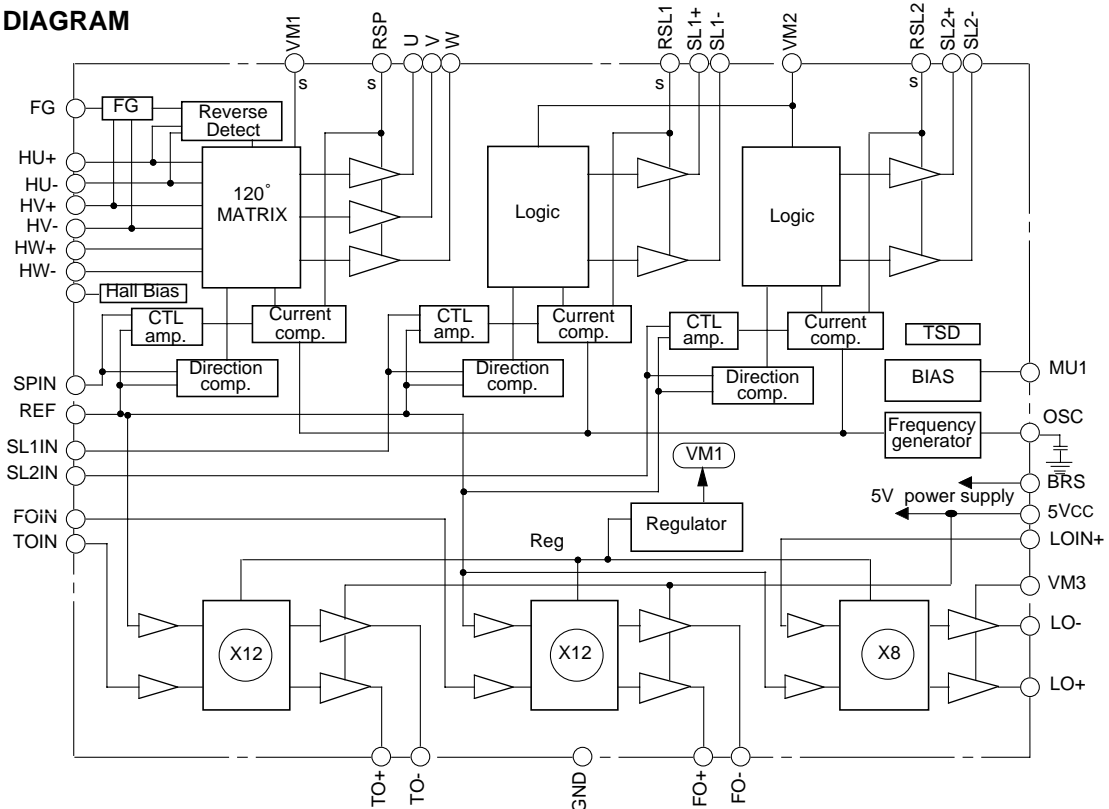

SPINDLE MOTOR AND 5CH ACTUATOR DRIVER

DESCRIPTIN OF PIN

Pin No.	Symbol	Function	Pin No.	Symbol	Function
1	SL1IN	Slide control voltage input 1	42	OSC	PWM carrier oscilation set
2	SL2IN	Slide control voltage input 2	41	MU1	mute 1
3	VM2	Motor Power Suppry 2(for Slide)	40	LOIN+	Loading control input(+)
4	RSL2	Slide current sense 2	39	VM3	Power Supply3(for Loading)
5	SL2+	Slide non-inverted output 2	38	BRS	Brake select control terminal
6	SL2-	Slide inverted output 2	37	LO-	Loading inverted output
7	GND	GND	36	LO+	Loading non-inverted output
8	RSL1	Slide current sense 1	35	FO-	Focus inverted output
9	SL1+	Slide non-inverted output 1	34	FO+	Focus non-inverted output
10	SL1-	Slide inverted output 1	33	GND	GND
11	GND	GND	32	TO+	Tracking non-inverted output
12	W	Motor drive output W	31	TO-	Tracking inverted output
13	V	Motor drive output V	30	5Vcc	5V Power Supply(for FS ,TS)
14	U	Motor drive output U	29	GND	GND
15	RSP	Spindle current sensie	28	TOIN	Tracking control voltage input
16	HW-	HW- sensor amp. input	27	FOIN	Focus control voltage input
17	HW+	HW+ sensor amp. input	26	SPIN	Spindle control voltage input
18	HV-	HV- sensor amp. input	25	REF	Reference voltage input
19	HV+	HV+ sensor amp. input	24	FG	Frequency generator output
20	HU-	HU- sensor amp. input	23	HB	Bias for Hall Sensor
21	HU+	HU+ sensor amp. input	22	VM1	Motor Power Suppry 1(for Spindle)

ABSOLUTE MAXIMUM RATINGS (Ta=25°C, unless otherwise noted)

Symbol	Parameter	Conditions	Ratings	Unit
5Vcc	5V power supply	Focus and Tracking power supply	7	V
VM1	Motor power supply 1	Spindle power supply	15	V
VM2	Motor power supply 2	Slide power supply	15	V
VM3	Motor power supply 3	Loading power supply	15	V
IoA	Motor Output Current A	Focus,Tracking and Loading output current Note1	1.0	A
IoB	Motor Output Current B	Spindle output current Note1	1.5	A
IoC	Motor Output Current C	Slide output current Note1	0.5	A
Vin	Maximum input voltage of terminals	MU1,Hw-,Hw+,Hv-,Hv+,Hu-,Hu+,REF,SPIN, BRS,TOIN, FOIN, OSC,SLIN1,SLIN2,LOIN+	0~5Vcc	V
Pt	Power dissipation	Free air and on the grass epoxy board 70mmX70mmX1.6mm	2.6	W
Kq	Thermal derating	Free air and on the grass epoxy board 70mmX70mmX1.6mm	20.8	mW/°C
Tj	Junction temperature		150	°C
Topr	Operating temperature		-20~+75	°C
Tstg	Storage temperature		-40~+150	°C

*note1 ; The ICs must be operated within the Pt (power dissipation) or the area of safety operation.

RECOMMENDED OPERATING CONDITIONS (Ta=25°C, unless otherwise noted)

Symbol	Parameter	Limits			Unit
		min.	typ.	max.	
VM1	VM1 power supply (for spindle)	6	12	13.2	V
VM2	VM2 power supply(for Slide)	4.5	12	13.2	V
VM3	VM3 power supply(for Loading)	4.5	12	13.2	V
5Vcc	5V power supply(for FS,TS)	4.5	5	7	V
IoA	Focus, Tracking and Loading Output Current	–	0.5	0.8	A
IoB	Spindle Output Current	–	0.5	1.0	A
IoC	Slide Output Current	–	0.25	0.4	A
Fosc	PWM carrier frequency	30	–	120	kHz

TYPICAL CHARACTERISTICS

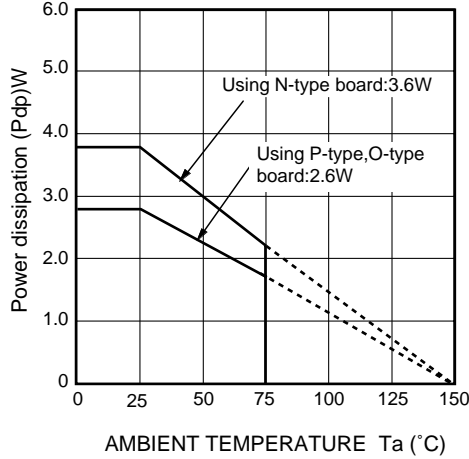

This IC's package is POWER-SSOP, so improving the board on which the IC is mounted enables a large power dissipation without a heat sink.
 For example, using an 1 layer glass epoxy resin board, the IC's power dissipation is 2.6W at least. And it comes to 3.6W by using an improved 2 layer board.
 The information of the N,P,O type board is shown in attached.

ELECTRICAL CHARACTERISTICS (Ta=25°C, 5Vcc=VM3=5V,VM1=VM2=12V unless otherwise noted.)

Symbol	Parameter	Test conditions	Limits			Unit
			Min.	Typ.	Max.	
Common						
Icc1	Supply current	5VCC,VM1, VM2 ,VM3 current	—	60	78	mA
Icc2	Sleep current	5VCC,VM1, VM2 ,VM3 current under Sleep (MU1=0V)	—	0	30	μA
Fosc	PWM carrier frequency	OSC : with 330pF	—	65	—	kHz
VinREF	REF input voltage range		1.0	—	3.3	V
IinREF	REF input current	VREF=1.65V	-10	—	+10	μA
VMULO	MUTE terminal low voltage	MU1	—	—	0.8	V
VMUHI	MUTE terminal high voltage	MU1	3.0	—	—	V
IMU	Mute terminal input current	MU1 at 5V input voltage	—	—	500	μA
BRSLO	BRS terminal low voltage	BRS	—	—	0.8	V
BRSHI	BRS terminal high voltage	BRS	3.0	—	—	V
IBRS	BRS terminal input current	BRS at 5V input voltage	—	—	430	μA
Spindle						
Vdyc1	Dynamic range of output	I _o =0.5 [A]	10.5	11.0	—	V
Vdead1-	Control voltage input range 1	SPIN<REF [REVERSE]	-80	-40	0	mV
Vdead1+		REF<SPIN [FORWARD]	0	+40	+80	mV
Vin1	Control voltage input range 1	SPIN	0	—	5	V
Gvo1	Control gain 1	G _{io1} =G _{vo1} / R _s [A/V]	0.85	1.0	1.15	V/V
Vlim1F	Control limit 1F	I _{lim1F} =V _{lim1F} / R _s [A]	0.4	0.5	0.6	V
Vlim1R	Control limit 1R	I _{lim1R} =V _{lim1R} / R _s [A]	0.22	0.28	0.34	V
VHcom	Hall sensor amp.common mode input range	Hu+,Hu-,Hv+,Hv-,Hw+, ,Hw-	1.3	—	3.7	V
VHmin	Hall sensor amp.input signal level	Hu+,Hu-,Hv+,Hv-,Hw+, ,Hw-	60	—	—	mVp-p
VHB	HB output voltage	at Load current (IHB)=10mA	0.6	0.85	1.2	V
IHB	HB terminal sink current	MU1=5V	—	—	30	mA
Slide1,2						
Vdyc2	Dynamic range of output	I _o =0.5 [A]	3.3	3.8	—	V
			at VM2=5[V] at VM2=12[V]	10.3	10.8	
Vdead2-	Control voltage dead zone 2	SL1IN,SL2IN < REF	-80	-40	0	mV
Vdead2+		REF < SL1IN ,SL2IN	0	+40	+80	mV
Vin2	Control voltage input range 2	SL1IN,SL2IN	0	—	5	V
Gvo2	Control gain 2	G _{io2} =G _{vo2} / R _s [A/V]	0.85	1.0	1.15	V/V
Vlim2	Control limit 2	I _{lim2} =V _{lim2} / R _s [A]	0.43	0.5	0.58	V
Tdon	Output turn-on delay	The time taken to turn on the output after the R _s voltage goes above the command value.	—	1.0	2.0	μsec
Tdoff	Output turn-off delay	The time taken to turn off the output after the R _s voltage goes down the command value.	—	2.0	3.5	μsec
Tdsw	Output switching delay	The time when all the output Tr.s are turned off during the switching of the output Tr.	—	3.0	6.0	μsec
Ileak	Output leak current	MU1=5v	-100	—	100	μA

SPINDLE MOTOR AND 5CH ACTUATOR DRIVER

ELECTRICAL CHARACTERISTICS (Ta=25°C, 5Vcc=VM3=5V,VM1=VM2=12V unless otherwise noted.)(cont.)

Symbol	Parameter	Test conditions	Limits			Unit	
			Min.	Min.	Max.		
Loading							
Vdyc3-1	Dynamic range of output	Io=0.5[A] VM1=12[V]	VM3=5[V]	3.9	4.2	—	V
			VM3=12[V]	6.9	7.6	—	
Vdyc3-2	Dynamic range of output	R=5.4[Ω], VM3=4.75V, VM1=12V	3.3	3.5	—	V	
Vin3	Control voltage input range 3	LOIN+	0	—	5	V	
Gvo3	Control gain 3	$\frac{(LO+) - (LO-)}{(LOIN+) - (REF)}$	16.7	18.1	19.3	dB	
Voff1	Output offset voltage	(LO+) - (LO-) at LOIN+=REF=1.65V	-50	0	+50	mV	
Focus/Tracking							
Vdyc4	Control voltage input range 4	Io=0.5[A], VM1=12[V]	3.8	4.2	—	V	
Vin4	Control gain 4	FOIN, TOIN	0	—	5	V	
Gvo4	Output offset voltage	$\frac{(FO+) - (FO-)}{FOIN - REF}$	20.2	21.6	22.8	dB	
		$\frac{(TO+) - (TO-)}{TOIN - REF}$					
Voff2	Output offset voltage	(FO+)-(FO-) at REF=FOIN=1.65V (TO+)-(TO-) at REF=TOIN=1.65V	-47	0	+47	mV	

Note 2. This IC need condenser between each supply lines and GND for stopped Oscillation.

THERMAL CHARACTERISTICS

Symbol	Parameter	Function start temperature of ic			Function stop temperature of ic			Unit
		Min.	Typ.	Max.	Min.	Typ.	Max.	
TSD	Thermal shut down	—	160	—	—	130	—	°C

Note 3. This TSD function start temperature doesn't show the guaranteed max. temperature of the devices.
 The guaranteed max. temperature is Tj max. which is shown in "9. ABSOLUTE MAXIMUM RATING". The TSD function is a thermal protection in case the temperature of the devices goes up above Tjmax because of wrong use.
 And these TSD temperature are the target temperatures for circuit design, not the guaranteed temperatures.
 (The TSD function of all the devices is not checked by a test in high temperature.)

● Standby function

	Logic control	Drive channel					
	MU1	Loading	Slide1	Slide2	Focus	Tracking	Spindle
SELECT2	H	On	On	On	On	On	On
SELECT1	L/Open	Off	Off	Off	Off	Off	Off

This IC has MUTE terminal (MU1).

It is possible to control ON / OFF of the channel by external logic inputs.

In case of SELECT1, the bias of all circuit becomes OFF.

Therefore, this mode is available in order to reduce the power dissipation when the waiting mode.

In case of SELECT2, the bias of all channel becomes ON.

● Brake select function

BRS	SPIN<REF	REF<SPIN
Hi	Reverse	Forward
L/Open	Short	Forward

This IC has BRS terminal (BRS).

It is possible for a braking timing of Spindle drive to select which the short brake or the reverse brake by BRS.

It should select the short brake in case of high speed system and please change to the reverse brake when the rotation speed becomes enough low. It is available when the SPIN voltage is low than the reference voltage.

● Loading channel

The loading channel is the circuit of BTL voltage drive. This circuit has the referential input. Output swing is determined with $\Delta V_{in} \times 8$. Also, it is possible for this channel to use for the slide motor, the focus coil and the tracking coil.

The input terminal is high impedance. It is possible to do variable gain by external resistor.

In case of one MCU port, if use three state port, it is possible for this channel to have the stop function.

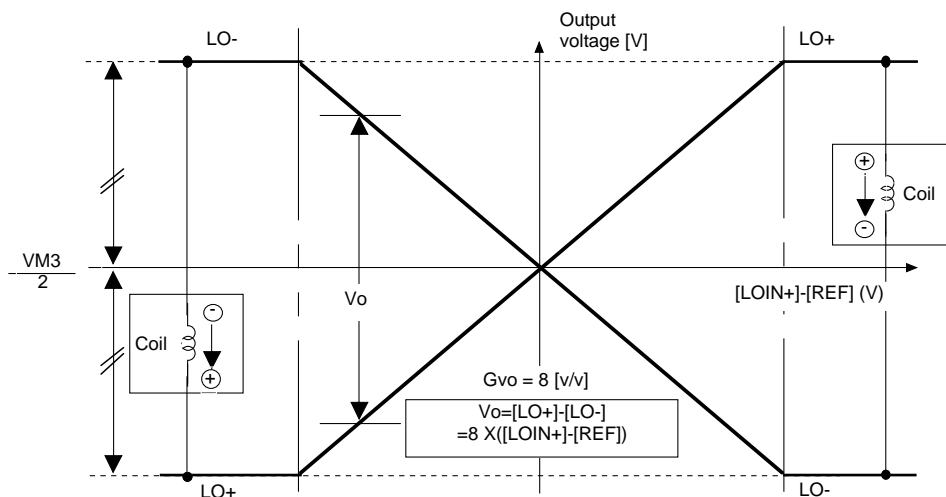
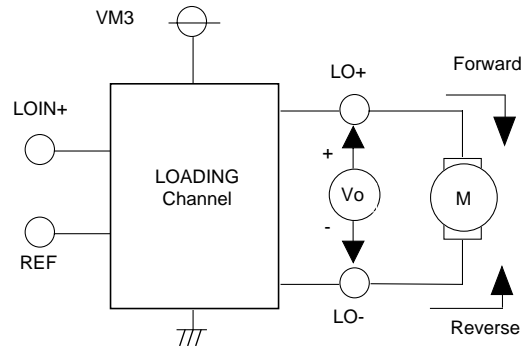

Application.1 (One port H/Z/L control)

Logic control P1	Situation of loading channel	Output voltage swing
5V	Forward rotation	$\frac{V_o = 8X(5[V] - REF[V])}{XR2/(R1+R2)}$
Z (Hi impedance)	Short brake --> Stop	$V_o = 0 [V]$
0	Reverse rotation	$\frac{V_o = -8X(5[V] - REF[V])}{XR2/(R1+R2)}$

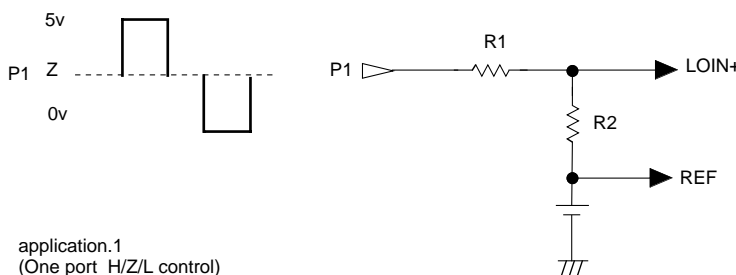

application.1 (One port H/Z/L control)

SPINDLE MOTOR AND 5CH ACTUATOR DRIVER

● Spindle channel

The relationship between the differential voltage between SPIN and REF and the torque is shown in right Figure. The voltage gain[Gvo] is 1.0 [V/V].

The current gain[Gio] is 2.0[A/V] (at sensing resistor : 0.5 ohm, and R1=∞,R2=0ohm) in forward torque directions, and the dead zone is from 0mV to 80mV (at R1=∞,R2=0ohm) .

The coil current gain under the reverse torque is the same with in forward torque directions. And the limitation function gets on when the differential voltage of VM1(12V)-RSP is 0.5V.

Therefore current-gain-control and current-limit of this IC is determined with sensing resistor value, and more detail control can be determined with setting a gain-resistor outer this IC as below.

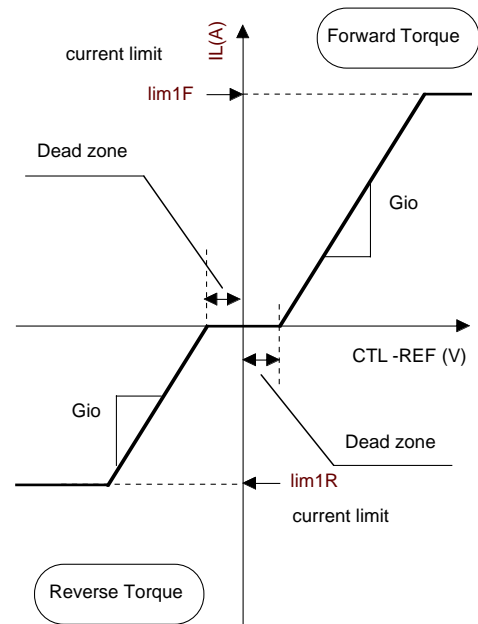

The example of current-gain and current-limit of spindle.

Rs [Ω]	Ilim1F [A]	Ilim1R [A]	Gio* [A/V]		
			R1=∞ R2=0 ohm	R1=R2	R1=2•R2
0.50	1.00	0.56	2.00	1.00	0.66
0.75	0.66	0.37	1.33	0.66	0.44
1.00	0.50	0.28	1.00	0.50	0.33

$$G_{io}^* = R1 / [(R1+R2) \cdot R_s] \text{ [A/V]}$$

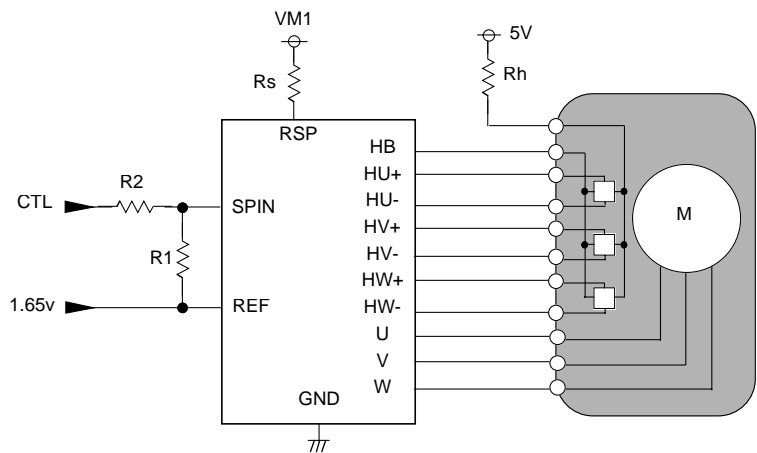

SPINDLE MOTOR AND 5CH ACTUATOR DRIVER

● Slide channel

The relationship between the differential voltage between SLIN and REF and the torque is shown in right Figure. The voltage gain[Gvo] is 1.0 [V/V]. The current gain is 2.0[A/V] (at sensing resistor : 0.5 ohm and R1=∞,R2=0ohm) in forward torque directions, and the dead zone is from 0mV to 80mV (at R1=∞,R2=0ohm)).

The coil current gain under the reverse torque is the same with in forward torque directions. And the limitation function gets on when the differential voltage of VM2(12V)-RSL is 0.5V.

Therefore current-gain-control and current-limit of this IC is determined with sensing resistor value.

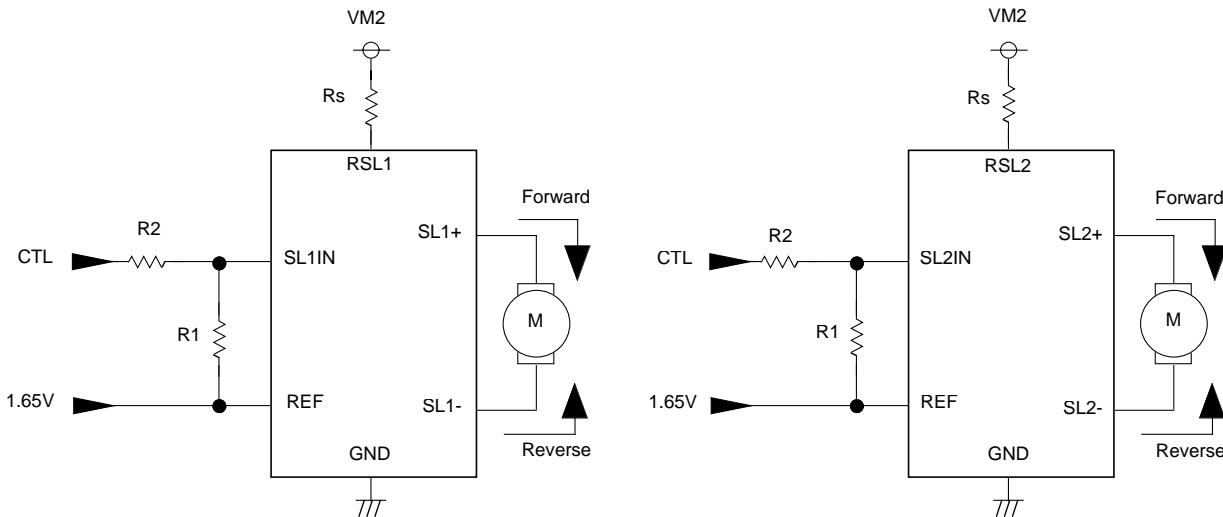
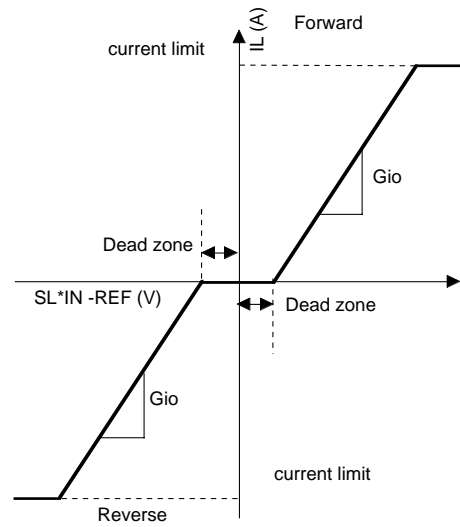

The example of current-gain and current-limit of slide.

Rs [Ω]	Ilim [A]	Gio* [A/V]		
		R1=∞,R2=0ohm	R1=R2	R1=2•R2
0.50	1.00	2.00	1.00	0.66
0.75	0.66	1.33	0.66	0.44
1.00	0.50	1.00	0.50	0.33

$$Gio^* = R1 / [(R1+R2) \cdot Rs] \text{ [A/V]}$$

● Focus/tracking channel

The focus and tracking channel is the voltage control drive using BTL .

The focus and tracking is the same composition.

The relationship between the differential voltage between FOIN and REF and the output voltage is shown in below Figure.

The voltage gain [Gvo] is 5.0 [V/V].

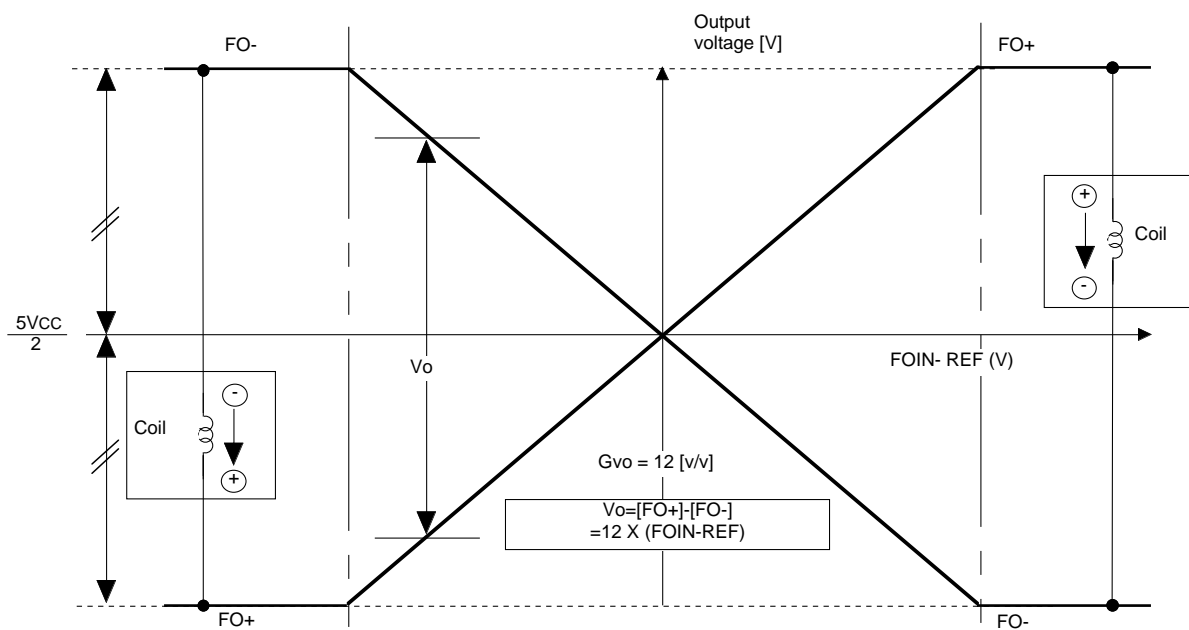
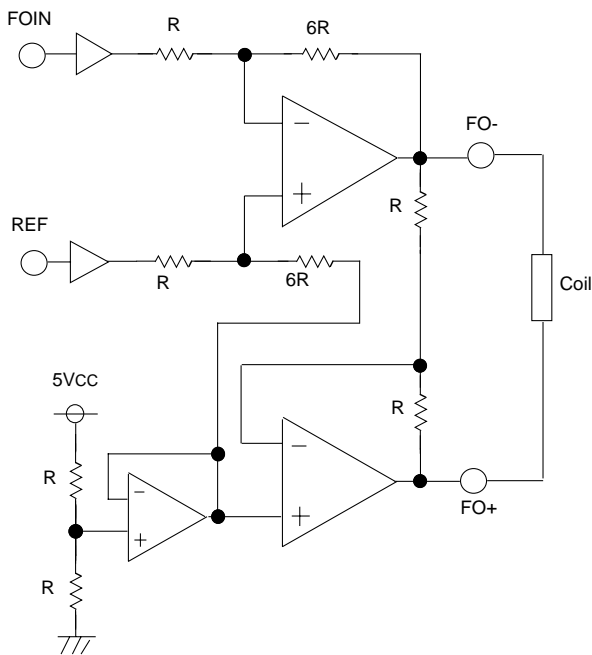

SPINDLE MOTOR AND 5CH ACTUATOR DRIVER

● Direct PWM operation

The spindle and the slide channel is controlled by the direct PWM control.

Also, built-in the current limit circuit. This IC controls the motor current directly.

FORWARD Current path timing 1.

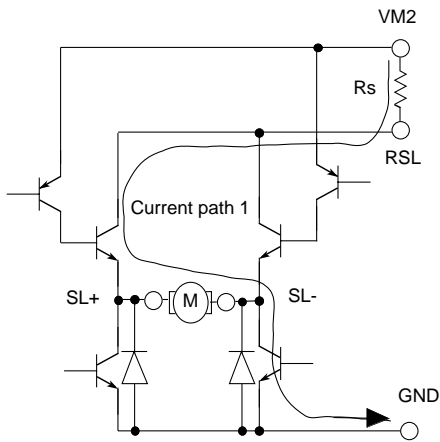

FORWARD Current path timing 2.

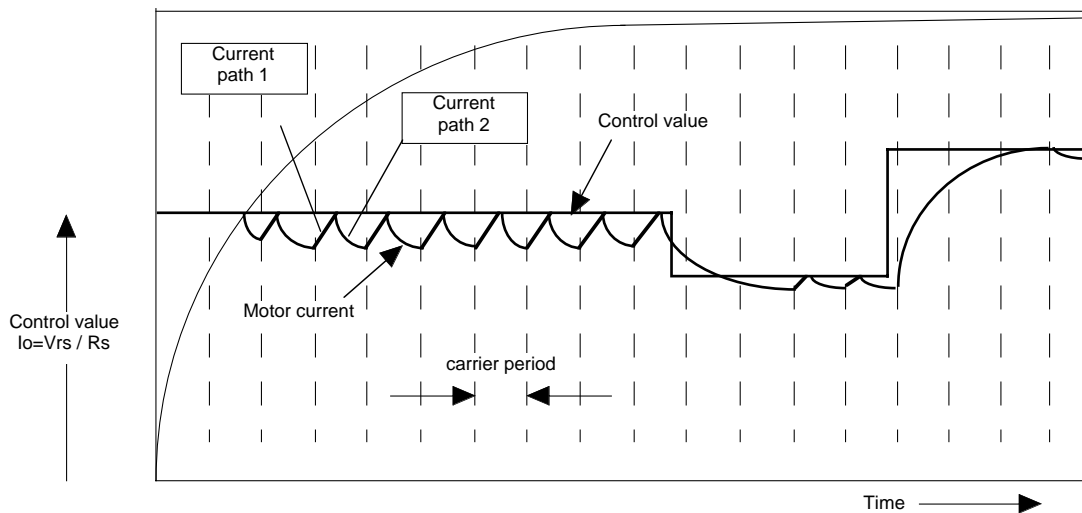
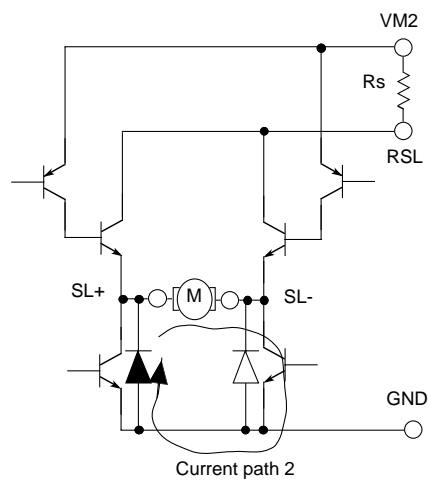

SPINDLE MOTOR AND 5CH ACTUATOR DRIVER

● PWM carrier frequency setting

PWM carrier frequency is decided by charging and discharging the capacitor that is connected to OSC terminal outer IC. Examination of the relationship the capacitor connected to OSC terminal and PWM carrier frequency is given in following table.

Capacitor [pF]	820	750	330	220	180	130	110
Carrier Frequency [kHz]	28	30	65	90	110	140	160

Note : This PWM carrier frequency is TYP value.

● Recommendation of short brake mode at spindle drive

This IC has two brake mode, PWM-BRAKE-MODE and SHORT-BRAKE-MODE. In this IC recommendation, SHORT-BRAKE-MODE is superior to PWM-BRAKE-MODE to reducing the power dissipation and to avoid braking down of this IC.

(By excessive reverse torque current in braking a motor with PWM-BRAKE from high-speed-rotation with being excessive Back-EMF, this IC could be broken.)

● The relationship between hall-amplifier-input and output-current-commutation/FG output at spindle drive

The relationship between the hall elements and the motor output current is shown in bellow Figure.

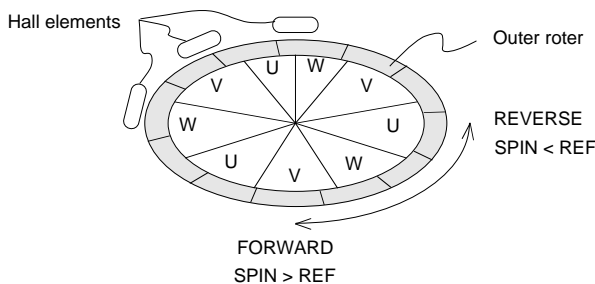
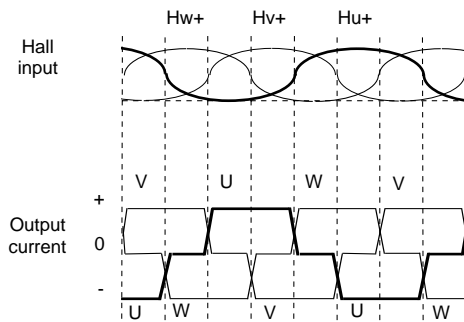

● FG function duty at spindle drive

The FG terminal outputs the square pulse signal synchronizing with the Hall inputs [Hv+, Hv-] timing.

And, the FG terminal is open-collector output.

● Phase delay circuit at slide

Phase delay circuit is built in the IC to detect an output spike current, when the motor current direction is switching.

In switching the motor current direction, Phase delay circuit switch-off all output transistor of H-bridge for 3μsec.

● Output current setting at slide

In this IC, since output transistor is NPN-type transistor, motor coil current (Io) is larger than sensing resistance current about 10mA (TYP.) according to base current of output transistor.

Therefore please design output current with consisting these base current.

SPINDLE MOTOR AND 5CH ACTUATOR DRIVER

I/O circuit

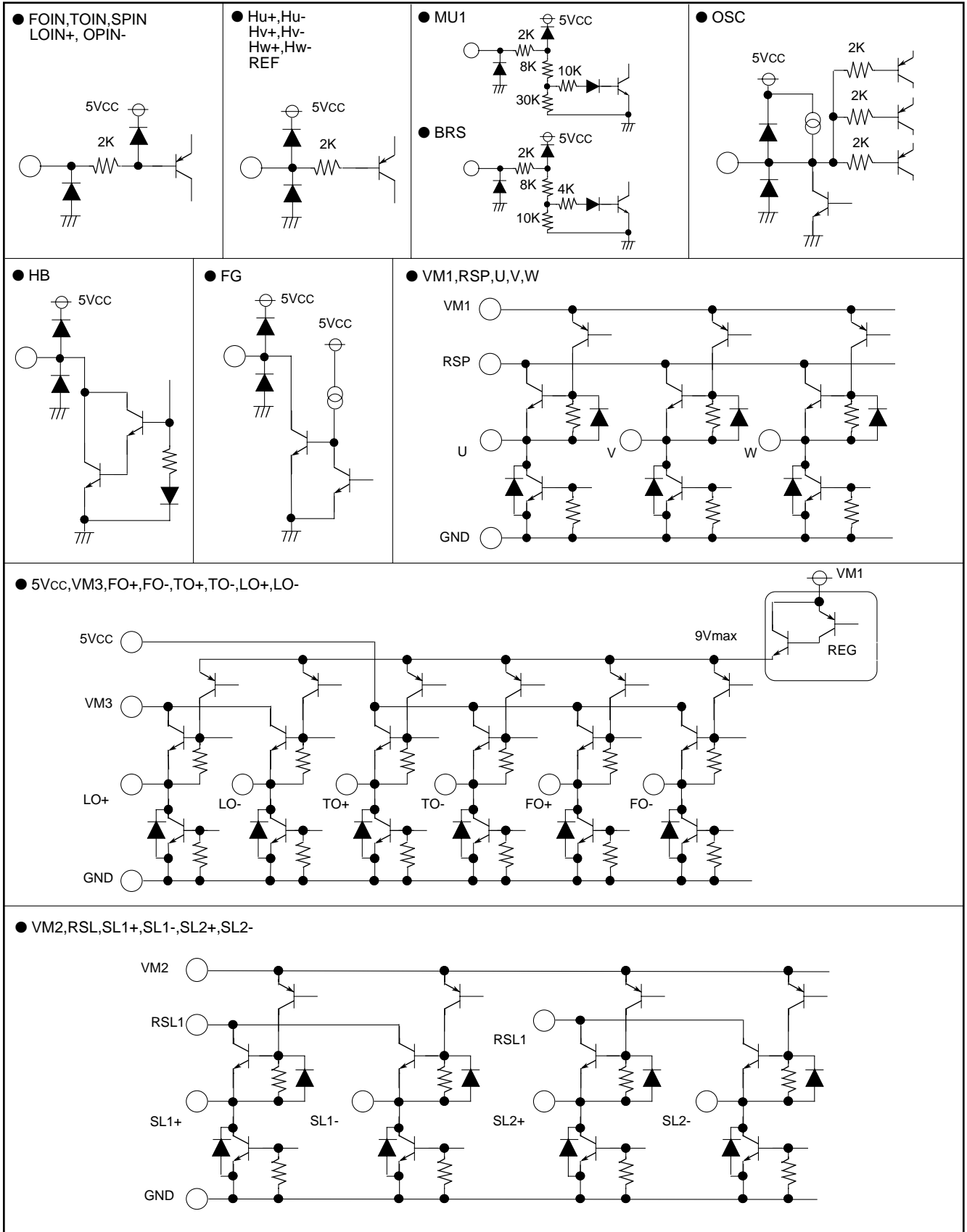

THE BOARDS FOR THERMAL DERATING EVALUATION

Board material
Glass-epoxy FR-4
Size
70X70mm
thickness
t=1.6mm
1 and 2 layers
material : copper
thickness : t=18μm

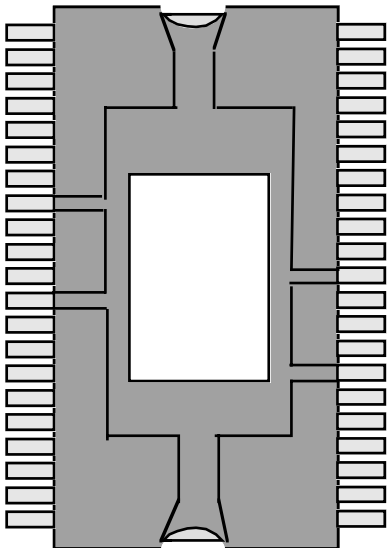

1st layer [TOP view]

2nd layer [BACK view]

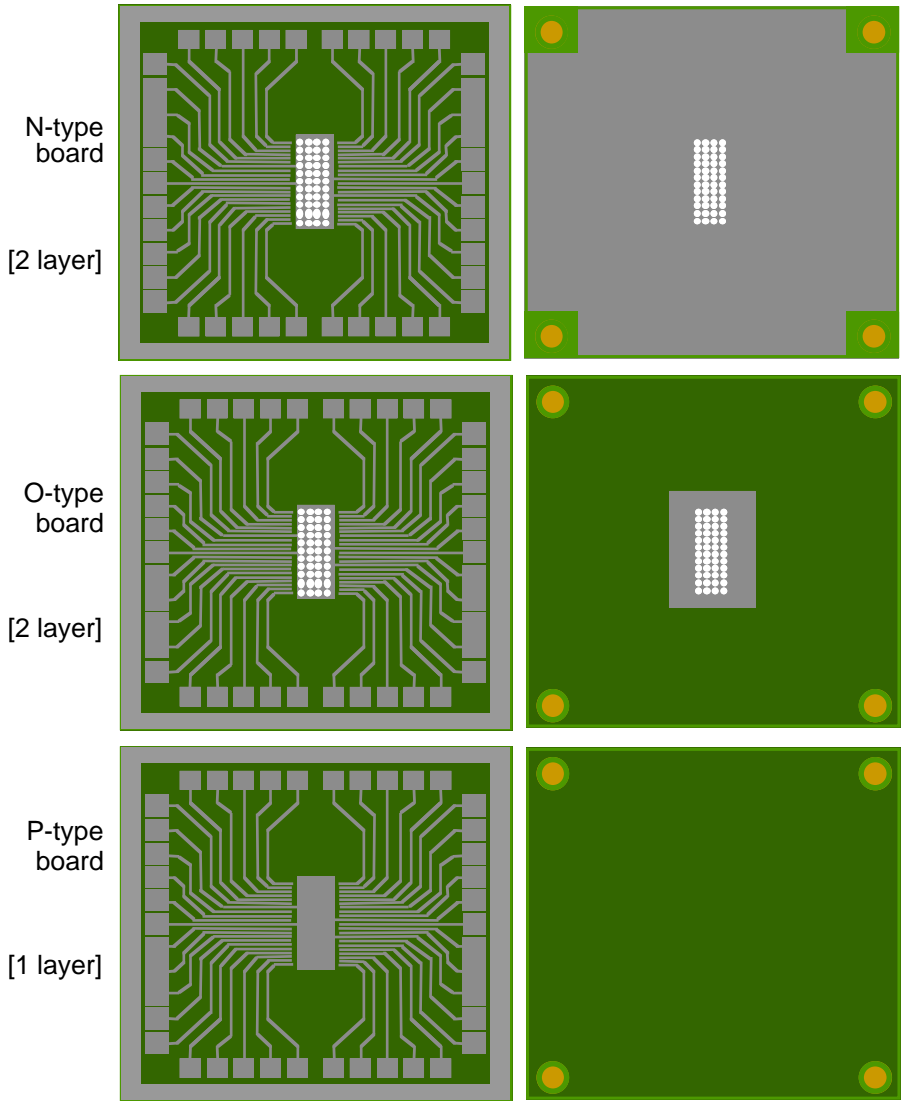

POWER-SSOP 42P9R-K/B

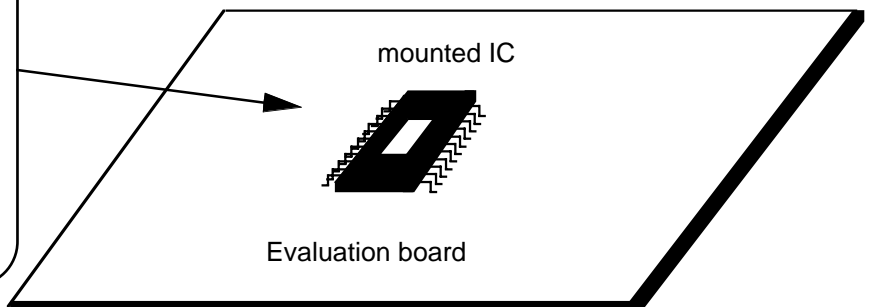
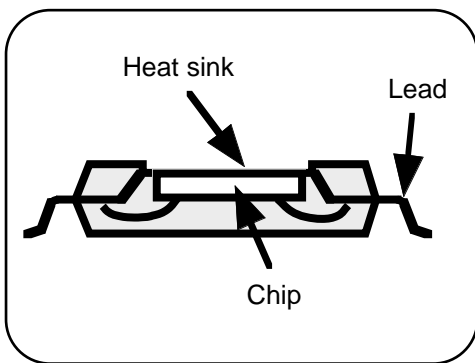

APPLICATION EXAMPLE

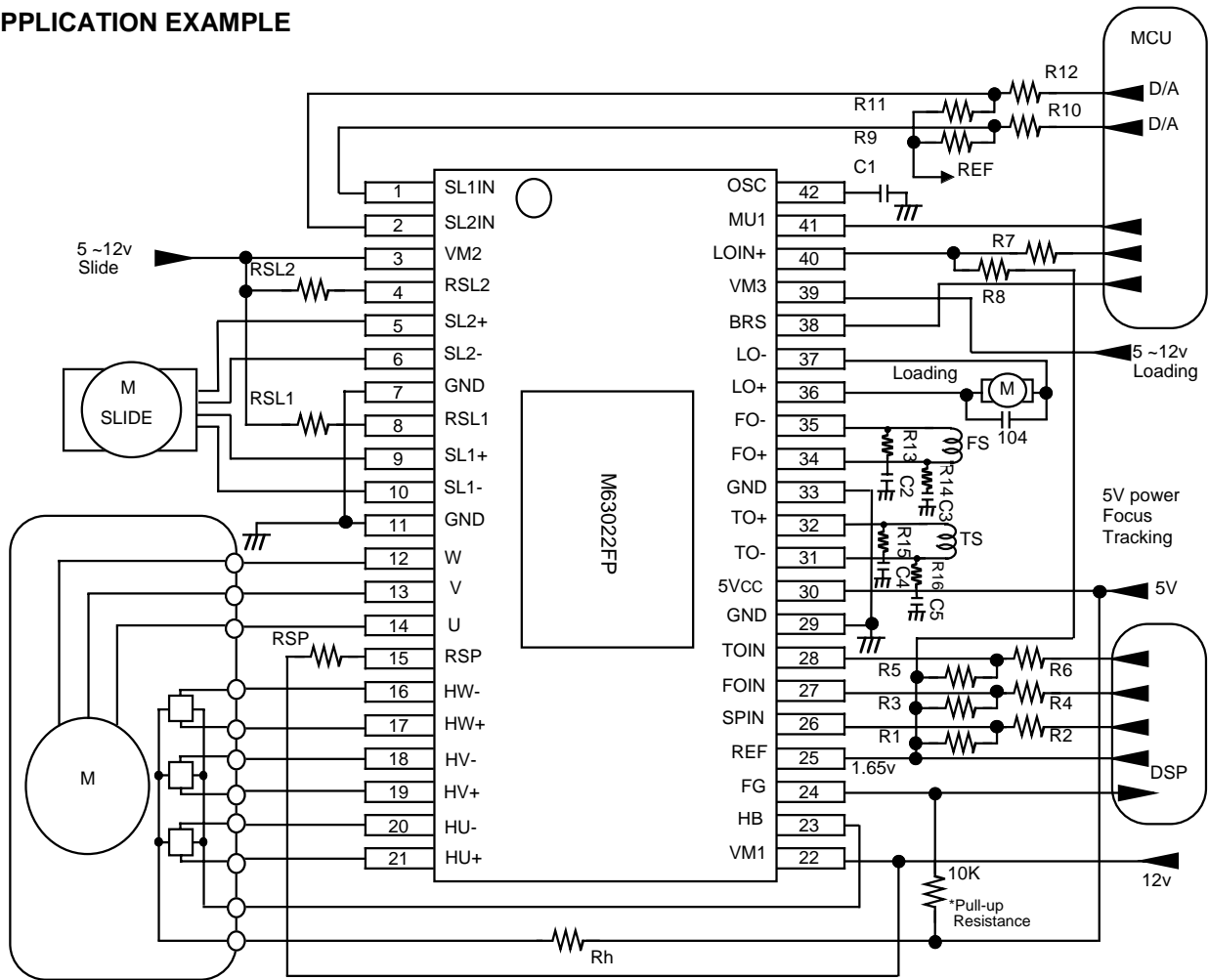

An example of the values of the external parts

These values are only examples, not the guaranteed values.

External parts name	Typ. value	Unit	Note
RPS	0.33	Ω	Ilim1F=1.5A, Ilim1R=1.0A, Gain=3.0A/V
RSL1,RSL2	2	Ω	Ilim=0.5A, Gain=1A/V
Rh	200	Ω	
R1,R2,R3,R4,R5,R6	10k	Ω	The values differ in each application.
R7, R8	10k	Ω	The values differ in each application.
C1	300p	F	Fosc=110kHz
R9,R10,R11,R12	10k	Ω	The values differ in each application.
R13,R14,R15,R16	22	Ω	
C2,C3,C4,C5	10n	F	

PACKAGE OUTLINE

42P9R-B

Plastic 42pin 450mil HSSOP

