

EiceDRIVER™

High voltage gate driver IC

1EDS20I12SV Evaluation Board for EconoDUAL™ 3 modules

Board description

1EDS20I12SV

EiceDRIVER™

Application note

AN2015-02

<Revision 1.5>, 07.06.2018

Edition 07.06.2018

**Published by
Infineon Technologies AG
81726 Munich, Germany**

**© 2018 Infineon Technologies AG
All Rights Reserved.**

Legal Disclaimer

The information given in this document shall in no event be regarded as a guarantee of conditions or characteristics. With respect to any examples or hints given herein, any typical values stated herein and/or any information regarding the application of the device, Infineon Technologies hereby disclaims any and all warranties and liabilities of any kind, including without limitation, warranties of non-infringement of intellectual property rights of any third party.

Information

For further information on technology, delivery terms and conditions and prices, please contact the nearest Infineon Technologies Office (www.infineon.com).

Warnings

Due to technical requirements, components may contain dangerous substances. For information on the types in question, please contact the nearest Infineon Technologies Office.

Infineon Technologies components may be used in life-support devices or systems only with the express written approval of Infineon Technologies, if a failure of such components can reasonably be expected to cause the failure of that life-support device or system or to affect the safety or effectiveness of that device or system. Life support devices or systems are intended to be implanted in the human body or to support and/or maintain and sustain and/or protect human life. If they fail, it is reasonable to assume that the health of the user or other persons may be endangered.

Revision History

Page or Item	Subjects (major changes since previous revision)
<Revision 1.5>, 07.04.2018	
p. 9	Corrected description of pin X1.18 and X1.19 in Table 2
p. 7	Insert errata page
all	Update IC parameter data to preliminary status and minor editorial changes
p. 8	Insert remark that module FF600R12ME4 is not delivered with evaluation board
p.20	Delete part U\$14 (module FF600R12ME4 is not delivered with evaluation board)

Trademarks of Infineon Technologies AG

AURIX™, BlueMoon™, C166™, CanPAK™, CIPOS™, CIPURSE™, COMNEON™, EconoPACK™, CoolMOS™, CoolSET™, CORECONTROL™, CROSSAVE™, DAVE™, EasyPIM™, EconoBRIDGE™, EconoDUAL™, EconoPIM™, EiceDRIVER™, eupec™, FCOS™, HITFET™, HybridPACK™, I²RF™, ISOFACE™, IsoPACK™, MIPAQ™, ModSTACK™, my-d™, NovalithIC™, OmniTune™, OptiMOS™, ORIGA™, PRIMARION™, PrimePACK™, PrimeSTACK™, PRO-SIL™, PROFET™, RASIC™, ReverSave™, SatRIC™, SIEGET™, SINDRION™, SIPMOS™, SMARTi™, SmartLEWIS™, SOLID FLASH™, TEMPFET™, thinQ!™, TRENCHSTOP™, TriCore™, X-GOLD™, X-PMU™, XMM™, XPOSYS™.

Other Trademarks

Advance Design System™ (ADS) of Agilent Technologies, AMBA™, ARM™, MULTI-ICE™, KEIL™, PRIMECELL™, REALVIEW™, THUMB™, μVision™ of ARM Limited, UK. AUTOSAR™ is licensed by AUTOSAR development partnership. Bluetooth™ of Bluetooth SIG Inc. CAT-iq™ of DECT Forum. COLOSSUS™, FirstGPS™ of Trimble Navigation Ltd. EMV™ of EMVCo, LLC (Visa Holdings Inc.). EPCOS™ of Epcos AG. FLEXGO™ of Microsoft Corporation. FlexRay™ is licensed by FlexRay Consortium. HYPERTERMINAL™ of Hilgraeve Incorporated. IEC™ of Commission Electrotechnique Internationale. IrDA™ of Infrared Data Association Corporation. ISO™ of INTERNATIONAL ORGANIZATION FOR STANDARDIZATION. MATLAB™ of MathWorks, Inc. MAXIM™ of Maxim Integrated Products, Inc. MICROTEC™, NUCLEUS™ of Mentor Graphics Corporation. Mifare™ of NXP. MIPI™ of MIPI Alliance, Inc. MIPS™ of MIPS Technologies, Inc., USA. muRata™ of MURATA MANUFACTURING CO., MICROWAVE OFFICE™ (MWO) of Applied Wave Research Inc., OmniVision™ of OmniVision Technologies, Inc. Openwave™ Openwave Systems Inc. RED HAT™ Red Hat, Inc. RFMD™ RF Micro Devices, Inc. SIRIUS™ of Sirius Satellite Radio Inc. SOLARIS™ of Sun Microsystems, Inc. SPANSION™ of Spansion LLC Ltd. Symbian™ of Symbian Software Limited. TAIYO YUDEN™ of Taiyo Yuden Co. TEAKLITE™ of CEVA, Inc. TEKTRONIX™ of Tektronix Inc. TOKO™ of TOKO KABUSHIKI KAISHA TA. UNIX™ of X/Open Company Limited. VERILOG™, PALLADIUM™ of Cadence Design Systems, Inc. VLYNQ™ of Texas Instruments Incorporated. VXWORKS™, WIND RIVER™ of WIND RIVER SYSTEMS, INC. ZETEX™ of Diodes Zetex Limited.

Last Trademarks Update 2010-10-26

Table of Contents

1	Scope and disclaimer	6
2	Errata page.....	7
3	Overview and design features	8
3.1	Design features	8
3.2	Key data and connector description	8
3.3	Mechanical description.....	9
4	Functional description.....	10
4.1	Minimum requirements.....	10
4.2	Power supply at connector X1	10
4.2.1	Supply of the two 1EDS20I12SV gate driver ICs VCC1/GND1 domains	10
4.2.2	Supply of the PADP/PADN domains of the two ICs.....	10
4.2.3	Supply of the two 1EDS20I12SV gate driver IC output sides	10
4.3	Control logic input signals	10
4.4	SPEED adjustment.....	11
4.5	Gate drive section	11
4.5.1	Turn-on gate current control.....	11
4.5.2	Turn-off.....	12
4.5.3	Two-level turn-off.....	13
4.6	Temperature measurement.....	13
4.7	Protection	14
4.7.1	Desaturation detection (DESAT) for Short Circuit Protection	14
4.7.2	Soft turn-off.....	15
4.8	Preparation for reinforced isolation according to VDE0884-10.....	15
5	Adapting the evaluation board to additional EconoDUAL™3 modules with different nominal currents	16
6	Bill of material (BOM).....	17
7	Schematics	22
8	Layout.....	27
	References.....	32

List of Figures

Figure 1	Evaluation board (Module FF600R12ME4 is not delivered with evaluation board)	8
Figure 2	E_{on} and dv_{CE}/dt achieved using the evaluation board at $T_C = 25^\circ\text{C}$ (solid lines) and $T_C = 125^\circ\text{C}$ (dashed lines) of selected speed levels	12
Figure 3	Schematic to convert the digital Σ/Δ stream "TEMP_D" to analog output "TEMP_A"	13
Figure 4	Characteristics of the temperature measurement	14
Figure 5	Disabling the automatic soft turn-off by solder joint for high side and low side channel	14
Figure 6	Components per channel for compliance to VDE0884-10	15
Figure 7	Schematic of high side channel gate driver	22
Figure 8	Schematic of low side channel gate driver	23
Figure 9	Schematic of isolated bipolar gate supply for high side and low side channel	24
Figure 11	Schematic of isolated NTC measurement signal	25
Figure 13	Schematic of RC-filters and supply selector including connector	26
Figure 15	Top layer (thick green lines are milling trenches to achieve a larger creepage distance)	27
Figure 16	Inner layer 1	28
Figure 17	Inner layer 2	29
Figure 18	Bottom layer	30
Figure 19	Assembly print	31

List of Tables

Table 1	Observed differences compared to the description of sections 3 – 8	7
Table 2	Operating range of voltages and currents at Connector X1	8
Table 3	9	
	Operating range of evaluation board with FF600R12ME4_B11	9
Table 4	Logic input and output parameter for connector X1 signals	11
Table 5	Bill of material for sigma-delta-stream to analog output conversion	13
Table 6	Component changes for the adaptation to FF450R12ME4_B11	16
Table 7	Bill of material	17

1 Scope and disclaimer

This document describes the setup and individual sections of the evaluation board EVAL-1EDS20I12SV from Infineon. It gives information about the operating range, its typical use and protection functions by means of layout and bill of materials. The bill of materials is selected for a direct use with the PressFIT type module FF600R12ME4_B11 (EconoDUAL™3) from Infineon Technologies. The board itself fits mechanically as well to other 600V and 1200V half bridge modules of the EconoDUAL3-family.

Changes at particular components on the board are mandatory for use this evaluation board with other modules than the FF600R12ME4_B11. This is also the case, when using the evaluation board with totally different power modules.

The board may be also used for non-PressFIT-type modules, when appropriate individual adaptations and connection are realized by the user for solder pin type modules. The board may be damaged in such cases.

The document covers the specification of the terminals of the board. Fulfilling the specification during operation results a stable working condition of the board.

This document refers to these other documents:

- Datasheet of 1EDS20I12SV
- Application note AN 2014-03 “1EDS20I12SV Technical description”

Reading these two documents prior to this application note helps to understand the evaluation board.

The evaluation board revision with the print “Rev. 1.0 / 2014-08” uses engineering samples. These samples fulfill the electrical characteristics. Safety relevant tests beyond 1200V between input and output are not allowed because of the engineering sample status.

Warnings



The described board is an evaluation board dedicated for laboratory environment only. It operates at high voltages. This board must be operated by qualified, skilled personnel familiar with all applicable safety standards.

2 Errata page

The following items are identified to be different with respect to the description in the sections 3 – 8. The affected evaluation board revision is Rev.1.0 with manufacturing date 2014-08.

Table 1 Observed differences compared to the description of sections 3 – 8

Observation	Affected components on board
Diode D_RDY1_T does not operate	D_RDY1_T
Signal TOP_RDY2 is continuously low	X1, IC300
Signal BOT_RDY2 indicate the status of the bottom IC terminal RDY1	X1, IC400
Signals BOT_RDY1 and TOP_RDY1 indicate the status of the related IC terminal RDY2	X1, IC300 and IC400

3 Overview and design features

This section provides an overview of the board and its design features.

3.1 Design features

The purpose of the evaluation board is to offer a reliable platform for evaluation of the product features provided by the EiceDRIVER™ 1EDS20I12SV (“1EDS-SRC”) in combination with EconoDUAL™3 modules from Infineon. The particular EiceDRIVER™ 1EDS20I12SV product features are:

- Desaturation detection with adjustable shut down delay
- Soft turn-off shut down
- Two-level turn-off
- Real time adjustable current source for slew rate control during IGBT turn-on
- Signature check of driver IC
- read out of each gate drive section status
- Control input signal amplitude up to 15V

The evaluation board itself also contains further features

- Two independent gate drive signals for half bridge configurations
- DC/DC power supply with short circuit protection
- Mechanically suitable for all 600 V and 1200 V EconoDUAL™3 modules
- Isolated temperature measurement

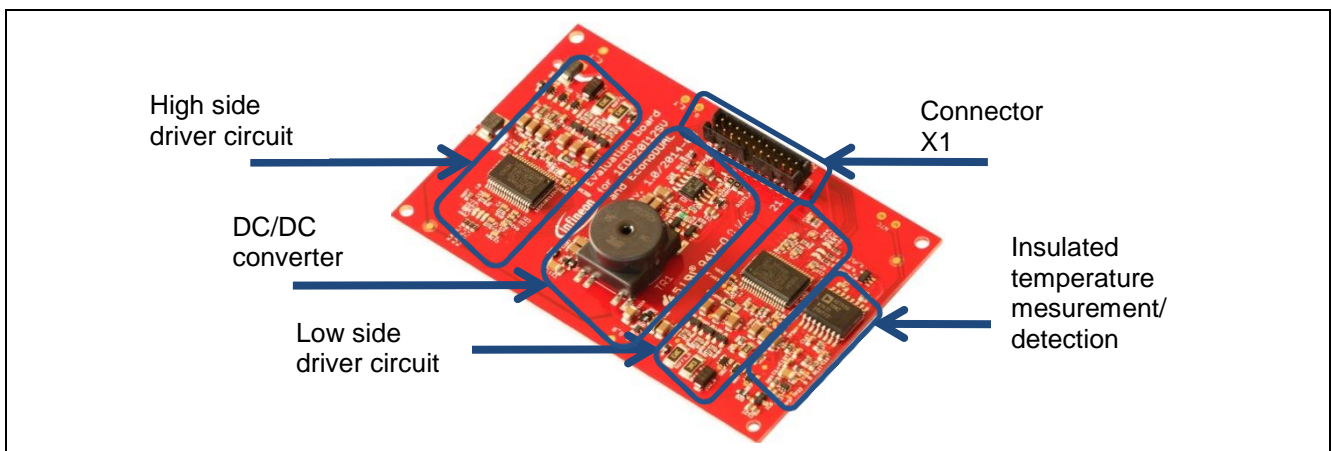

Figure 1 Evaluation board (Module FF600R12ME4 is not delivered with evaluation board)

3.2 Key data and connector description

Unless noted otherwise all parameters refer to GND1 potential and to $T_A = 25^\circ\text{C}$.

Table 2 Operating range of voltages and currents at Connector X1

Pin	Parameter	Description	Symbol	Min.	Max.	Unit
X1-1	MCLOCK	Clock out for temperature measurement	V_{MCLOCK}	0	V_{VCC1}	V
X1-2	VCC15	+15 V supply for SMPS	V_{VCC15}	14.5	15.5	V
		Supply current for SMPS (PWM = 0)	I_{VCC15}	typ. 75		mA
		Supply current for SMPS (20kHz)		typ. 142		
X1-3	GNDDC	Reference voltage for SMPS	V_{GNDDC}	-	-	V
X1-4	TOP_INN	High side inverting control signal	$V_{\text{TOP_INN}}$	0	V_{VCC1}	

Table 2 Operating range of voltages and currents at Connector X1

Pin	Parameter	Description	Symbol	Min.	Max.	Unit
X1-5	TOP_INP	High side non-inverting control signal	V_{TOP_INP}	0	V_{VCC1}	
X1-6	TOP_RDY1	High side RDY1 output signal	V_{TOP_RDY1}	0	V_{VCC1}	
X1-7	TOP_RDY2	High side RDY2 output signal	V_{TOP_RDY2}	0	V_{VCC1}	
X1-8	TOP_SPEED	High side SPEED input	V_{TOP_SPEED}	0	V_{VCC1}	
X1-9	TOP_EN	High side EN input signal	V_{TOP_EN}	0	V_{VCC1}	
X1-10	TOP_/FLT	High side /FLT output signal	$V_{TOP_/FLT}$	0	V_{VCC1}	
X1-11	SIGI	Signature input signal	V_{SIGI}	0	V_{VCC1}	
X1-12	SIGO	Signature output signal	V_{SIGO}	0	V_{VCC1}	
X1-13	BOT_/FLT	Low side /FLT output signal	$V_{BOT_/FLT}$	0	V_{VCC1}	
X1-14	BOT_EN	Low side EN input signal	V_{BOT_EN}	0	V_{VCC1}	
X1-15	BOT_SPEED	Low side SPEED input signal	V_{BOT_SPEED}	0	V_{VCC1}	
X1-16	BOT_RDY1	Low side RDY1 output signal	V_{BOT_RDY1}	0	V_{VCC1}	
X1-17	BOT_RDY2	Low side RDY2 output signal	V_{BOT_RDY2}	0	V_{VCC1}	
X1-18	BOT_INN	Low side inverting control signal	V_{BOT_INN}	0	V_{VCC1}	
X1-19	BOT_INP	Low side non-inverting control	V_{BOT_INP}	0	V_{VCC1}	
X1-20	TEMP	Insulated NTC output signal	V_{TEMP}	tbd	V_{VCC1}	
		Output current	I_{TEMP}	-	5	mA
X1-21	VCC1	Positive power supply input side 5V	V_{VCC1}	4.85	5.15	V
X1-22	GND1	Reference voltage for V_{VCC1}	V_{GND1}	-	-	

Table 3 Operating range of evaluation board with FF600R12ME4_B11

Parameter	Symbol	Min.	Max.	Unit
Operating ambient temperature ¹	T_{OP}	-	85	°C
PWM signal frequency for high side and low side ¹	f_P	-	10	kHz
duty cycle of PWM signal for high side or low side	d	0	100	%
Max. working isolation voltage AD7400 Sigma-Delta Converter	V_{IORM}		891	V

3.3 Mechanical description

The evaluation board mechanically fits to EconoDUAL™3 modules. The board is designed for use in combination with PressFIT contacts. Use of modules with solder pin is possible, when appropriate individual adaptations and connection are realized by the user for solder pin type modules. The board may be damaged in such cases..

The PCB dimensions are 64 mm x 100 mm.

It is mandatory to refer to the product and mounting specifications of the individual module for further information in respect to the special requirements of PressFIT contacts.

¹ Maximum operating temperature and switching frequency strictly depends on load and cooling conditions. The maximum switching frequency for every EconoDUAL™ 3 module type should be calculated separately. Limitation factors include max. DC/DC output power of 1.5 W per channel and max. PCB board temperature measured in close proximity to the gate resistors with a limit of 105 °C for the FR4 material used. The board is designed to operate a FF600R12ME4 module up to 10 kHz.

4 Functional description

The function set for high side and low side switch has the same default setting. The notation in this document for signals of connector X1, which apply to the high side and the low side switch, uses an “x”. For example “x_INP” is a synonym for TOP_INP and BOT_INP. The notation for signals which have identical function for the low side and the high side channel uses “signalT/B” or “signal_T/B”. For example “GND2_T/B” is a synonym for GND2_T and GND2_B. The notation for specific components on the evaluation board, which have identical function for the high side channel and the low side channel, is done by using “component_T/B” or “componentT/B”. For example “D1T/B” is a synonym for the diodes D1T and D1B.

4.1 Minimum requirements

The following requirements must be fulfilled in order to get the evaluation board ready for operation:

- Assemble the evaluation board correctly to the FF600R12ME4_B11 module according to [3].
- x_INN is connected to GND1 and control signal is connected to x_INP or x_INP is connected to VCC1 and active low control signal is connected to x_INN
- x_EN is connected to VCC1
- +5V and its reference are connected to X1-21 (VCC1) and X1-22 (GND1)
- +15V and its referenced is supplied to X1-2 (VCC15) and X1-3 (GNDDC)
- In case of operation without a power module, the anodes or cathodes of diodes D1T and D1B are to be connected to the terminal GND2 of the individual low side or high side channel. A desaturation event would be detected with the first turn-on signal otherwise, and the /FLT_B/T LED will be activated.

The board indicates ready for operation, when the 4 green LED (x_RDY1, x_RDY2) are activated and the two red LED (x_/FLT) are off.

4.2 Power supply at connector X1

This section describes the default setting of the power supply section including options.

4.2.1 Supply of the two 1EDS20I12SV gate driver ICs VCC1/GND1 domains

The VCC1 / GND1 domain supply voltage of both driver ICs is supplied to the evaluation board via the terminals X1-21 (VCC1) and X1-22 (GND1).

4.2.2 Supply of the PADP/PADN domains of the two ICs

The PADP / PADN domain supply voltage of both driver ICs is connected to the VCC1 domain. Therefore, only control signals up to a maximum of 5.15V are allowed on the input side by default.

The evaluation board offers the option to supply the PADP / PADN domain with 15V as well. This allows applying control signals for x_INP, x_INN and x_EN with an amplitude of 15V. The option can be used by removing the two 0 Ω resistors RJ2T1 and RJ4T1 and by adding the two 0 Ω resistors RJ1T1_NC and RJ3T1_NC.

4.2.3 Supply of the two 1EDS20I12SV gate driver IC output sides

The evaluation board offers a DC/DC converter onboard for the output section supply of the high side and low side switch. This includes an additional negative voltage in order to establish bipolar gate voltage to the IGBT. The SMPS is supplied from a 15V source and provides output voltages of $V_{VEE2} = -8V$ and $V_{VCC2} = +16V$ for each output. Each output voltage is clamped by zener diodes. The use of the SMPS enables the output sides to manage the complete range of duty cycles from 0 to 100%. The SMPS is short circuit proof as a special function.

The input voltage of the converter is supplied to the evaluation board via the terminals X1-2 (VCC15) and X1-3 (GNDDC). No additional voltage supply is required. Connecting GNDDC and GND1 is not mandatory.

4.3 Control logic input signals

The default assembly of the evaluation board requires control input signals (x_INN, x_INP, x_EN) which fulfil the switching levels of Table 4. RC-filters at each input of the driver IC 1EDS20I12SV help to suppress noise.

The evaluation board provides three status signals (x_RDY1, x_RDY2 and x_/FLT) for each gate drive IC. Each signal is visualized by a LED. x_RDY1 and x_RDY2 use green LEDs and x_/FLT uses a red LED, when the signal is activated. The voltage levels of the output signals x_RDY1, x_RDY2 and x_/FLT of both the high side and low side IGBT driver IC have the behavior acc. to Table 4.

Table 4 Logic input and output parameter for connector X1 signals

Parameter	Symbol	Values			Unit	Test condition
		Min.	Typ.	Max.		
Low level input voltage terminals x_INP, x_INN, x_EN	V_{IL}	1.5	–	–	V	
High level input voltage terminals x_INP, x_INN, x_EN	V_{IH}	–	–	3.5		
Low level input voltage terminals SIGI	$V_{IL,SIGI}$	1.5	–	–		
High level input voltage terminals SIGI	$V_{IH,SIGI}$	–	–	3.5		
Low level output voltage terminals SIGO	$V_{OL,SIGO}$	V_{GND1}	0.1	0.3		$I_{IL,SIGO} = 3 \text{ mA}$
High level output voltage terminals SIGO	$V_{OH,SIGO}$	4.3	4.7	V_{VCC1}		$I_{IL,SIGO} = -3 \text{ mA}$
Low level output voltage terminals /FLT, RDY1, RDY2	$V_{OL,FLT}$, $V_{OL,RDY1}$, $V_{OL,RDY2}$	–	0.08 0.1 0.1	0.3 0.3 0.3		$I_{IL,pin} = 3 \text{ mA}$

4.4 SPEED adjustment

The real-time adjustment of the turn-on switching speed by means of the 1EDS20112SV gate current control needs an analog signal. RC-filters at each input of the driver IC 1EDS20112SV help to filter the signals. The evaluation board accepts a PWM signal with >100 kHz from the microcontroller/DSP over X1-8 and X1-13 of connector X1 for each x_SPEED input according to section 3.2. Alternatively, an analog signal can be applied at terminals x_SPEED of connector X1.

4.5 Gate drive section

4.5.1 Turn-on gate current control

The 1EDS20112SV gate current control IC provides 11 levels of gate current after the preboost phase according to the table below.

	Voltage at terminal SPEED	% of preboost current
Level 1	3.3 V	19.7%
Level 2	2.91 V	28.70%
Level 3	2.63 V	37.60%
Level 4	2.35 V	46.60%
Level 5	2.08 V	55.60%
Level 6	1.80 V	64.50%
Level 7	1.52 V	73.50%
Level 8	1.25 V	82.50%
Level 9	0.97 V	91.20%
Level 10	0.69 V	100%
Level 11	0	154%

The 11 levels of turn-on gate current result in different collector-emitter voltage transients dv_{CE}/dt and turn-on energies E_{on} according to Figure 2.

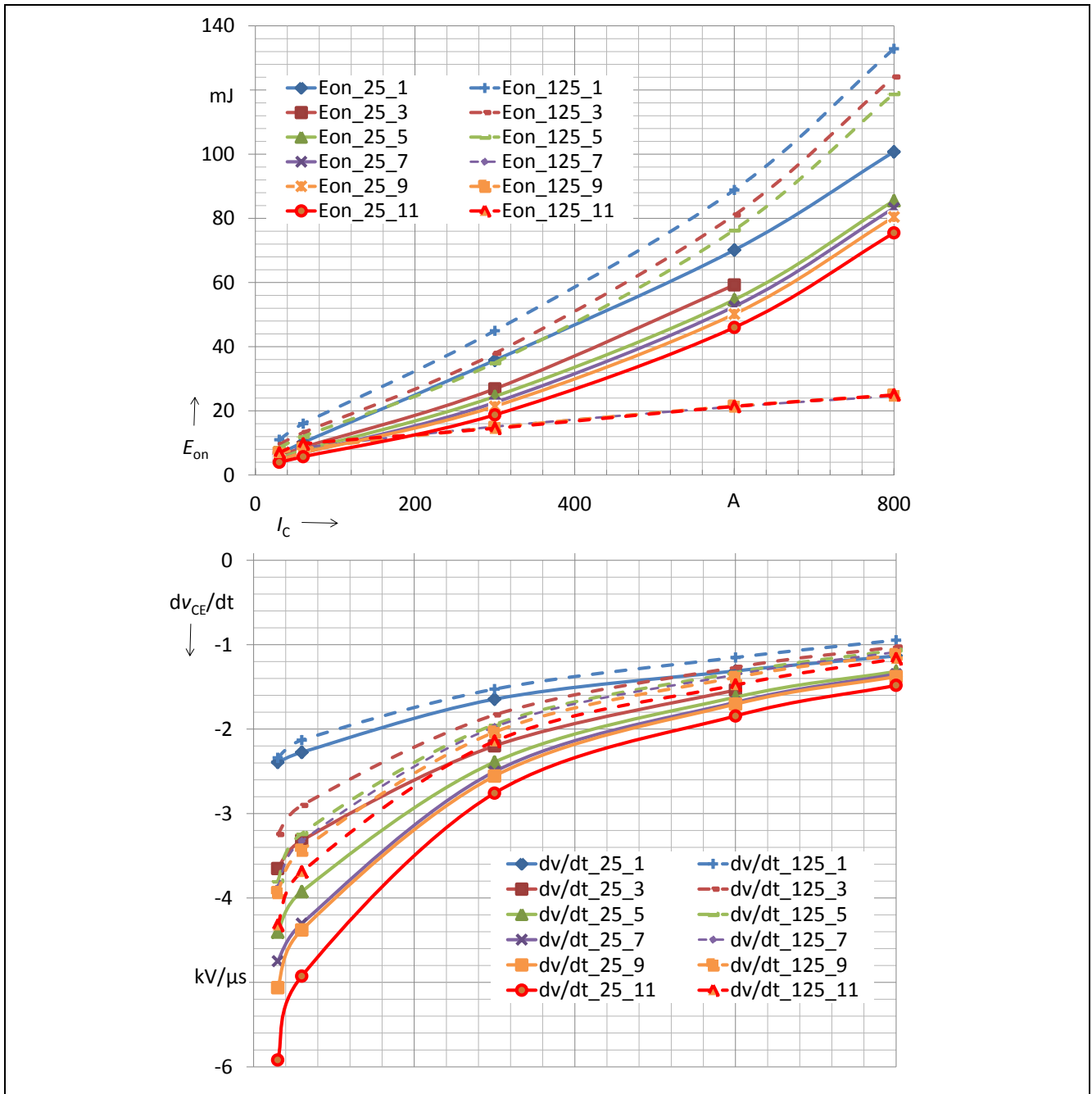

Figure 2 E_{on} and dv_{CE}/dt achieved using the evaluation board at $T_c = 25^\circ\text{C}$ (solid lines) and $T_c = 125^\circ\text{C}$ (dashed lines) of selected speed levels

4.5.2 Turn-off

The turn-off speed is controlled by the resistors ROFF_T/B and ROFF1_T/B acc. to Figure 7 and Figure 8. An external booster using PNP transistors provides a high turn-off current capability. Two $3.3\ \Omega$ resistors in parallel result in $1.65\ \Omega$, which is close to the datasheet value of the EconoDUAL™3 power module FF600R12ME4_B11. The turn-off behavior of the evaluation board in combination with this module is therefore similar as described in the datasheet.

4.5.3 Two-level turn-off

By default, the two-level turn-off function is set to a level of 10.3 V and a duration of $T_{TLSET} = 2 \mu s$. A higher level can be configured:

- assemble resistors RZ_T/B with 27 kΩ each which results in a two-level voltage of $V_{TLTO} = 9.3 V$ or
- replacing resistors RZ_T/B by 0 Ω, which results in a two-level voltage of $V_{TLTO} = 11.4 V$.

A higher two-level voltage can result in an inductive overshoot. It is therefore mandatory to check the resulting overvoltage during turn-off in case of changing the default two-level voltage. The transient collector-emitter voltage v_{CE} must stay below the maximum rating of the used power module.

4.6 Temperature measurement

The evaluation board offers the IGBT base plate temperature measurement in the range of $-40 \text{ °C} \dots 150 \text{ °C}$. The measurement setup includes a sigma-delta converter. Thus a digital signal is provided featuring the advantage that digital signal processing can be used without particular hardware efforts and that the subsequent error is low. However, an analog signal can be produced with the use of the schematic in Figure 3.

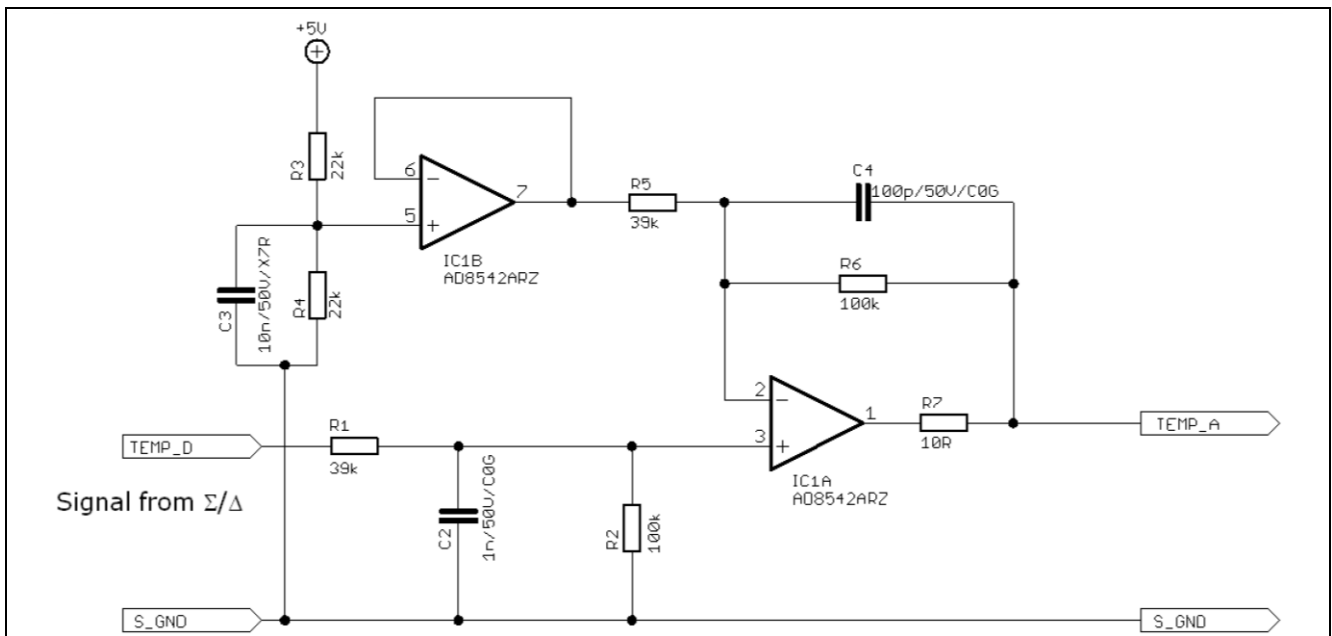

Figure 3 Schematic to convert the digital Σ/Δ stream “TEMP_D” to analog output “TEMP_A”

Table 5 Bill of material for sigma-delta-stream to analog output conversion

Name	Value (Tolerance)	Package	Supplier
C1	100n/50V/X7R (10%)	C0603	various
C2	1n/50V/C0G (5%)	C0603	various
C3	10n/50V/X7R (10%)	C0603	various
C4	100p/50V/C0G (5%)	C0603	various
IC1	AD8542ARZ	SO8	Analog Devices
R1, R5	39k (1%)	R0603	various
R2, R6	100k (1%)	R0603	various
R3, R4	22k (1%)	R0603	various
R7	10R (1%)	R0603	various

C1 is the buffer for the supply voltage of IC1. C1 is not visible in Figure 3.

Using the base plate temperature and a thermal model, the junction temperature can be estimated. The complexity of the thermal model needed for this purpose depends on application and heat sink conditions as

well as on requirements regarding accuracy and dynamic response. In case of a broken wire the output shuts down to 0 V. The relation between output voltage and base plate temperature is shown in Figure 4.

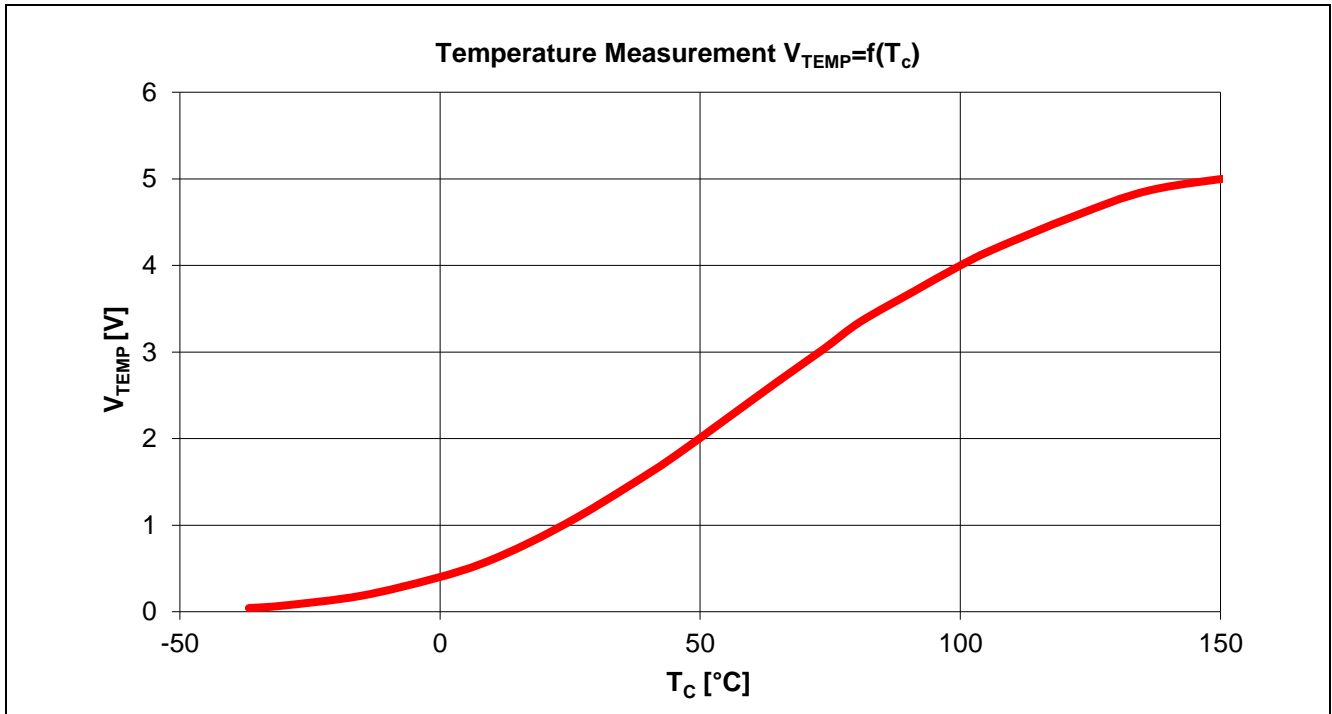

Figure 4 Characteristics of the temperature measurement

4.7 Protection

4.7.1 Desaturation detection (DESAT) for Short Circuit Protection

The evaluation board uses the desaturation detection function for both channels to detect a short circuit event. The DESAT blanking time is set for approximately $T_{DESAT} = 4\mu s$. This delay is needed to prevent false detection due to capacitive effects in the later application.

The datasheet of the 1EDS20I12SV [1] and the application note AN2014-03 [2] provide further information on this function.

The affected channel is latched in off-state after performing an automatic soft turn-off procedure. A logic low pulse at terminal x_EN at connector X1 longer than 800 ns resets the channel and the related IGBT is controlled immediately according to the input signal status of this channel (x_INP, x_INN, x_EN).

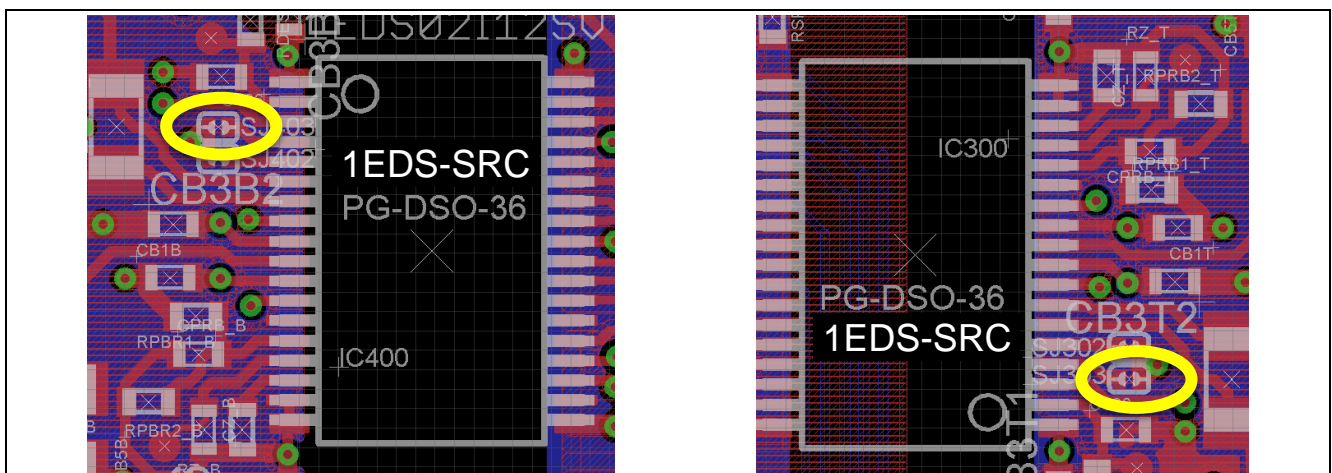

Figure 5 Disabling the automatic soft turn-off by solder joint for high side and low side channel

The automatic soft turn-off process can be disabled by activating the OCOFF function, when shorting the jumper SJ303 and SJ403 by a solder joint indicated in Figure 5.

4.7.2 Soft turn-off

The soft turn-off function is activated by default with a soft turn-off resistor of RSOFF_T/B = 47 Ω as given in [2].

4.8 Preparation for reinforced isolation according to VDE0884-10

The standard VDE0884-10 demands that the power dissipation of the IC is never above its absolute maximum ratings – even in case of fatal damage of the application. This is fulfilled by additional components which allow keeping away high power from the IC safely even in cases where the IGBT is damaged.

The two components DZ1_T/B and DZ2_T/B are suppressor diodes parallel to the driver IC. The breakdown mode of such diodes is a short. This will keep away excessive power from the IC, once DZ1_T/B or DZ2_T/B are overloaded and damaged. The IC is therefore safe.

The resistors R2 and R4 are series resistors between the output power supply and the IC. The breakdown mode of resistors in case of overload is “open”. This also guarantees a disconnection of the 1EDS2012SV from an excessive power device.

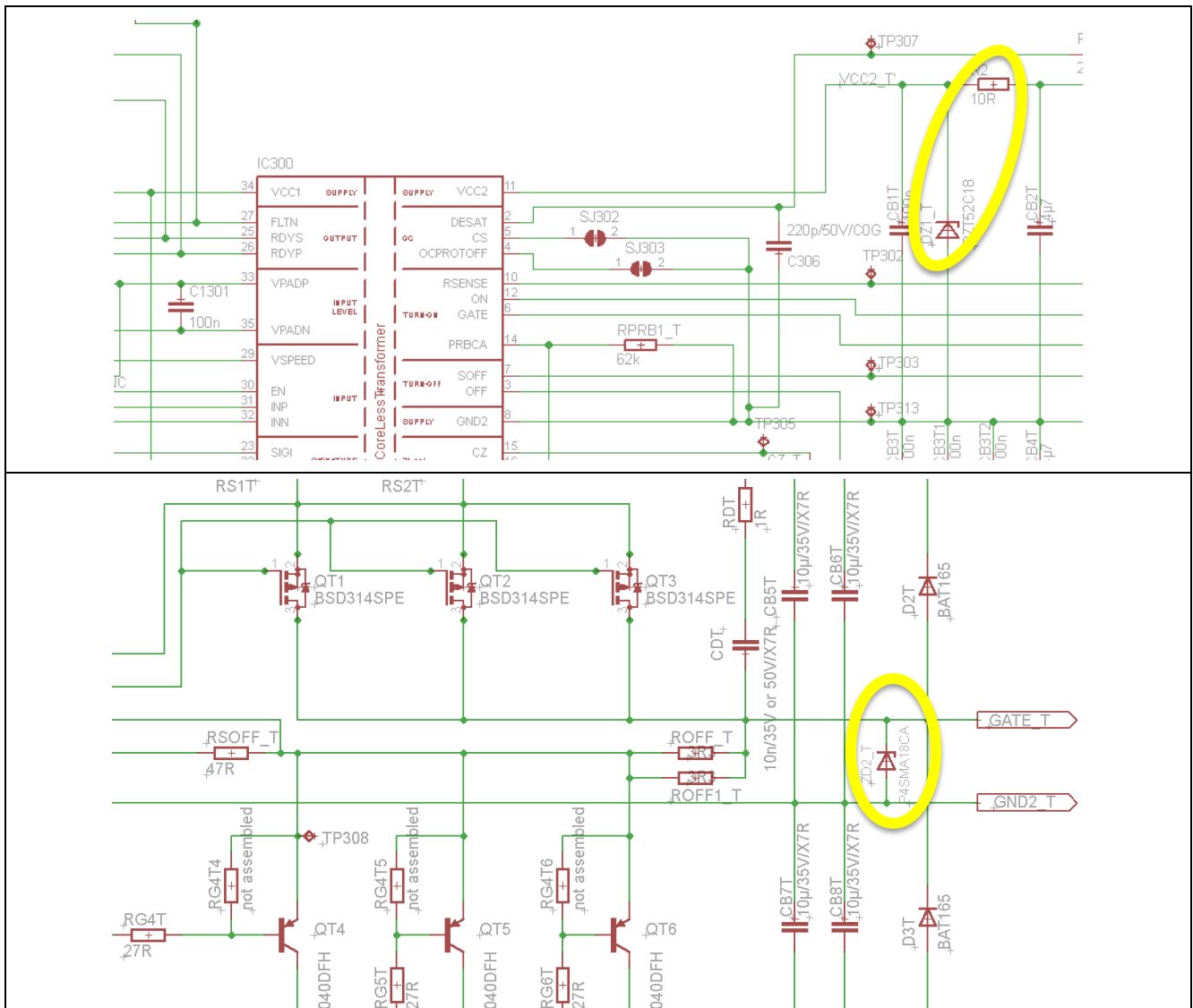

Figure 6 Components per channel for compliance to VDE0884-10

5 Adapting the evaluation board to additional EconoDUAL™3 modules with different nominal currents

This section provides the changes in the bill of materials for the evaluation board. All changes must be performed with great care. Otherwise, modifications of the evaluation board may lead to damages. The FF450R12ME4_B11 module also uses an EconoDUAL™3 package. Therefore the evaluation board can be used for this module when replacing selected components on the evaluation board. Table 1 shows the required changes in the bill of materials.

Table 6 Component changes for the adaptation to FF450R12ME4_B11

Component	FF600R12ME4_B11	FF450R12ME4_B11
ROFF1_B	3R3	1R
ROFF1_T	3R3	1R
ROFF_B	3R3	1R
ROFF_T	3R3	1R
RS1B	0R33	0R47
RS1T	0R33	0R47
RS2B	0R33	0R47
RS2T	0R33	0R47

6 Bill of material (BOM)

Table 7 Bill of material

Name	Value	Device	Package	Supplier
C1	100p/50V/C0G	Capacitor	0603	various
C2	100n/50V/X7R	Capacitor	0603	various
C3	1n/50V/X7R	Capacitor	0603	various
C4	1n/50V/X7R	Capacitor	0603	various
C5	1n / 50V / X7R	Capacitor	0603	various
C6	100n/50V/X7R	Capacitor	0603	various
C7	4μ7/25V/X7R	Capacitor	1206	various
C8	1n/50V/X7R	Capacitor	0603	various
C9	1n/50V/X7R	Capacitor	0603	various
C9B	4μ7/25V/X7R	Capacitor	1206	various
C9T	4μ7/25V/X7R	Capacitor	1206	various
C10	100p/50V/C0G	Capacitor	0603	various
C10B	4μ7/25V/X7R	Capacitor	1206	various
C10T	4μ7/25V/X7R	Capacitor	1206	various
C11	1μ/25V/X7R	Capacitor	0805	various
C11B	4μ7/25V/X7R	Capacitor	1206	various
C11T	4μ7/25V/X7R	Capacitor	1206	various
C12	1n / 50V / X7R	Capacitor	0603	various
C12T	1μ/25V/X7R	Capacitor	0805	various
C13T	1μ/25V/X7R	Capacitor	0805	various
C14	4μ7/25V/X7R	Capacitor	1206	various
C14T	4μ7/25V/X7R	Capacitor	1206	various
C15	4μ7/25V/X7R	Capacitor	1206	various
C15T	10n/50V/X7R	Capacitor	0603	various
C16	4μ7/25V/X7R	Capacitor	1206	various
C16T	10n/50V/X7R	Capacitor	0603	various
C17	1n / 50V / X7R	Capacitor	0603	various
C17T	10n/50V/X7R	Capacitor	0603	various
C18	1n / 50V / X7R	Capacitor	0603	various
C18T	100n/50V/X7R	Capacitor	0603	various
C19	100n	Capacitor	0603	various
C20	100n	Capacitor	0603	various
C21	100n	Capacitor	0603	various
C22	100n	Capacitor	0603	various
C306	220p/50V/C0G	Capacitor	0603	various
C406	220p/50V/C0G	Capacitor	0603	various
C1304	10n	Capacitor	0603	various
C1404	10n	Capacitor	0603	various
CB1B	100n	Capacitor	0603	various
CB1T	100n	Capacitor	0603	various
CB2B	4μ7/25V/X7R	Capacitor	1206	various
CB2T	4μ7/25V/X7R	Capacitor	1206	various
CB3B	100n	Capacitor	0603	various
CB3B1	100n	Capacitor	0603	various

Name	Value	Device	Package	Supplier
CB3B2	100n	Capacitor	0603	various
CB3T	100n	Capacitor	0603	various
CB3T1	100n	Capacitor	0603	various
CB3T2	100n	Capacitor	0603	various
CB4B	4μ7/25V/X7R	Capacitor	1206	various
CB4T	4μ7/25V/X7R	Capacitor	1206	various
CB5B	4μ7/25V/X7R	Capacitor	1206	various
CB5T	4μ7/25V/X7R	Capacitor	1206	various
CB6B	4μ7/25V/X7R	Capacitor	1206	various
CB6T	4μ7/25V/X7R	Capacitor	1206	various
CB7B	4μ7/25V/X7R	Capacitor	1206	various
CB7T	4μ7/25V/X7R	Capacitor	1206	various
CB8B	4μ7/25V/X7R	Capacitor	1206	various
CB8T	4μ7/25V/X7R	Capacitor	1206	various
CDB	10n/25V/X7R	Capacitor	0603	various
CDT	10n/25V/X7R	Capacitor	0603	various
CPRB_B	1n	Capacitor	0603	various
CPRB_T	1n/50V/C0G	Capacitor	0603	various
CZ_B	680p/50V/C0G	Capacitor	0603	various
CZ_T	680p/50V/C0G	Capacitor	0603	various
D1B	STTH112U	1200V Ultrafast Rectifier	SOD6	
D1R	BAT64-02WSMA	Single Schottky Diodes	SCD80	Infineon
D1T	STTH112U	1200V Ultrafast Rectifier	SOD6	
D2B	BAT165	Diode	SOD323R	Infineon
D2T	BAT165	Diode	SOD323R	Infineon
D3B	BAT165	Diode	SOD323R	Infineon
D3R	BAT64-02WSMA	Diode	SCD80	Infineon
D3T	BAT165	Diode	SOD323R	Infineon
D4B	BAT165	Diode	SOD323R	Infineon
D4T	BAT165	Diode	SOD323R	Infineon
D5	BAT165	Diode	SOD323R	Infineon
D5B	BAT165	Diode	SOD323R	Infineon
D5T	BAT165	Diode	SOD323R	Infineon
D6B	BAT165	Diode	SOD323R	Infineon
D6T	BAT165	Diode	SOD323R	Infineon
D_FLT_B	OSRAM Q65110	LED	CHIPLED_0603	Osram
D_FLT_T	OSRAM Q65110	LED	CHIPLED_0603	Osram
D_RDY1_B	OSRAM Q65110	LED	CHIPLED_0603	Osram
D_RDY1_T	OSRAM Q65110	LED	CHIPLED_0603	Osram
D_RDY2_B	OSRAM Q65110	LED	CHIPLED_0603	Osram
D_RDY2_T	OSRAM Q65110	LED	CHIPLED_0603	Osram
IC3	IR2085SPBF	Gate driver	S008	IR
IC4	SN74LVC1G17D	Logic gate	SOT23-5	
IC5	AD7400YRWZ	Isol. Sigma-Delta Modulator	DSO16	Analog Devices
IC6	ZMR500FTA	5V regulator	SOT23	
IC7	TLV431BIDCKT	Precision shunt regulator	SC70-6L	
IC300	1EDS20I12SV	Gate current control IC	DSO36	Infineon

Name	Value	Device	Package	Supplier
IC400	1EDS20112SV	Gate current control IC	DSO36	Infineon
OCOFF_B		Solder joint		
OCOFF_T		Solder joint		
QB1	BSD314SPE	p-channel MOSFET	SOT363	Infineon
QB1_	BSS314PE	p-channel MOSFET	Not assembled	Infineon
QB2	BSD314SPE	p-channel MOSFET	SOT363	Infineon
QB2_	BSS314PE	p-channel MOSFET	Not assembled	Infineon
QB3	BSD314SPE	p-channel MOSFET	SOT363	Infineon
QB3_	BSS314PE	p-channel MOSFET	Not assembled	Infineon
QB4	ZXTP25040DFH	pnP-Transistor	SOT23	Diodes
QB5	ZXTP25040DFH	pnP-Transistor	SOT23	Diodes
QB6	ZXTP25040DFH	pnP-Transistor	SOT23	Diodes
QT1	BSD314SPE	p-channel MOSFET	SOT363	Infineon
QT1_	BSS314PE	p-channel MOSFET	Not assembled	Infineon
QT2	BSD314SPE	p-channel MOSFET	SOT363	Infineon
QT2_	BSS314PE	p-channel MOSFET	Not assembled	Infineon
QT3	BSD314SPE	p-channel MOSFET	SOT363	Infineon
QT3_	BSS314PE	p-channel MOSFET	Not assembled	Infineon
QT4	ZXTP25040DFH	pnP-Transistor	SOT23	Diodes
QT5	ZXTP25040DFH	pnP-Transistor	SOT23	Diodes
QT6	ZXTP25040DFH	pnP-Transistor	SOT23	Diodes
R1	100R	Resistor	0603	various
R2	10R	Resistor	0603	various
R3	100R	Resistor	0603	various
R4	10R	Resistor	0603	various
R8T'	0R	Resistor	0603	various
R9T'	1k2	Resistor	0603	various
R10T'	820R	Resistor	0603	various
R11T'	2k2	Resistor	0603	various
R12T'	270R	Resistor	0603	various
R13T'	2k2	Resistor	0603	various
R14	68k	Resistor	0603	various
R15	15R	Resistor	0603	various
R16	15R	Resistor	0603	various
R17	2k2	Resistor	0603	various
R18	0R15	Resistor	0805	various
R42	100R	Resistor	0603	various
R43	100R	Resistor	0603	various
R44	100R	Resistor	0603	various
R46	100R	Resistor	0603	various
R47	100R	Resistor	0603	various
R48	100R	Resistor	0603	various
R56	3k9	Resistor	0603	various
RDB	1R	Resistor	0603	various
RDESAT_B	2k2	Resistor	0603	various
RDESAT_T	2k2	Resistor	0603	various
RDT	1R	Resistor	0603	various

Name	Value	Device	Package	Supplier
RG4B	27R	Resistor	0603	various
RG4B4	not assembled	Resistor	0603	various
RG4B5	not assembled	Resistor	0603	various
RG4B6	not assembled	Resistor	0603	various
RG4T	27R	Resistor	0603	various
RG4T4	not assembled	Resistor	0603	various
RG4T5	not assembled	Resistor	0603	various
RG4T6	not assembled	Resistor	0603	various
RG5B	27R	Resistor	0603	various
RG5T	27R	Resistor	0603	various
RG6B	27R	Resistor	0603	various
RG6T	27R	Resistor	0603	various
RJ1T1_NC	not assembled	Resistor	0805	various
RJ2T1	0R	Resistor	0805	various
RJ3T1_NC	not assembled	Resistor	0805	various
RJ4T1	0R	Resistor	0805	various
ROFF1_B	3R3	Resistor	2010	various
ROFF1_T	3R3	Resistor	2010	various
ROFF_B	3R3	Resistor	2010	various
ROFF_T	3R3	Resistor	2010	various
RS1B	0R33	Resistor	1206	various
RS1T	0R33	Resistor	1206	various
RS2B	0R33	Resistor	1206	various
RS2T	0R33	Resistor	1206	various
RSOFF_B	47R	Resistor	1206	various
RSOFF_T	47R	Resistor	1206	various
RSPB	2k7	Resistor	0603	various
RSPT	2k7	Resistor	0603	various
RZ_B_NC	not assembled	Resistor	0603	various
RZ_T_NC	not assembled	Resistor	0603	various
R_FLT_B	2k4	Resistor	0603	various
R_FLT_T	2k4	Resistor	0603	various
R_PBR1_B	62k	Resistor	0603	various
R_PBR2_B	15k	Resistor	0603	various
R_PRB1_T	62k	Resistor	0603	various
R_PRB2_T	15k	Resistor	0603	various
R_RDY1_B	2k4	Resistor	0603	various
R_RDY1_T	2k4	Resistor	0603	various
R_RDY2_B	2k4	Resistor	0603	various
R_RDY2_T	2k4	Resistor	0603	various
T3	PMV45EN	n-channel MOSFET	SOT23	
T4	PMV45EN	n-channel MOSFET	SOT23	
TR1	T60403-F5046-X100	Transformer	---	Vacuumschmelze
X1	MILLIGRID-22	Connector	MILLIGRID-22 female	Molex
X1'	MILLIGRID-22	connector	MILLIGRID-22 male	Molex
ZD1_B	P4SMA18CA	P4SMA18CA	DO214AC	



Name	Value	Device	Package	Supplier
ZD1_T	P4SMA18CA	P4SMA18CA	DO214AC	
ZD2_B	P4SMA18CA	P4SMA18CA	DO214AC	
ZD2_T	P4SMA18CA	P4SMA18CA	DO214AC	

7 Schematics

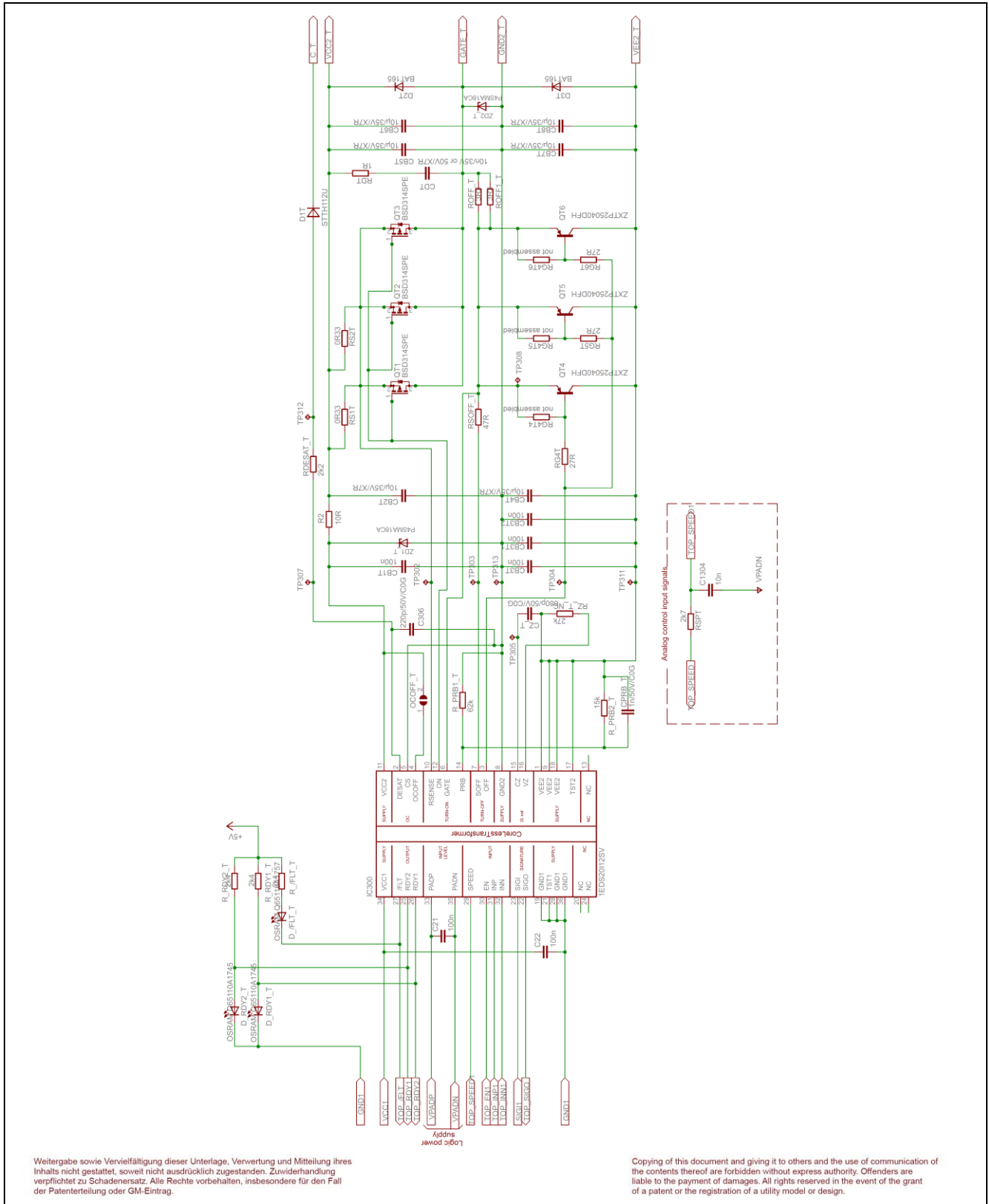

Figure 7 Schematic of high side channel gate driver

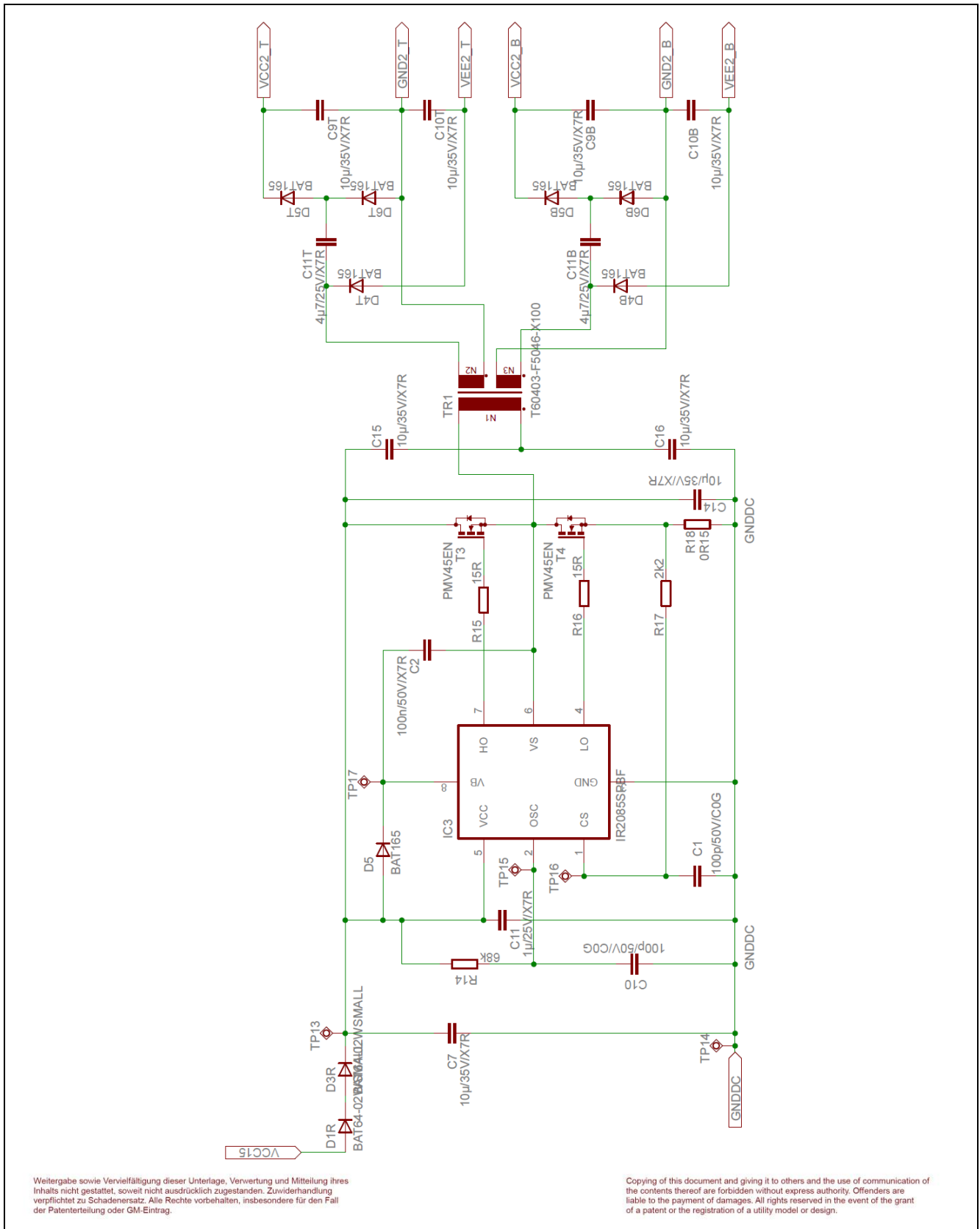

Figure 9 Schematic of isolated bipolar gate supply for high side and low side channel

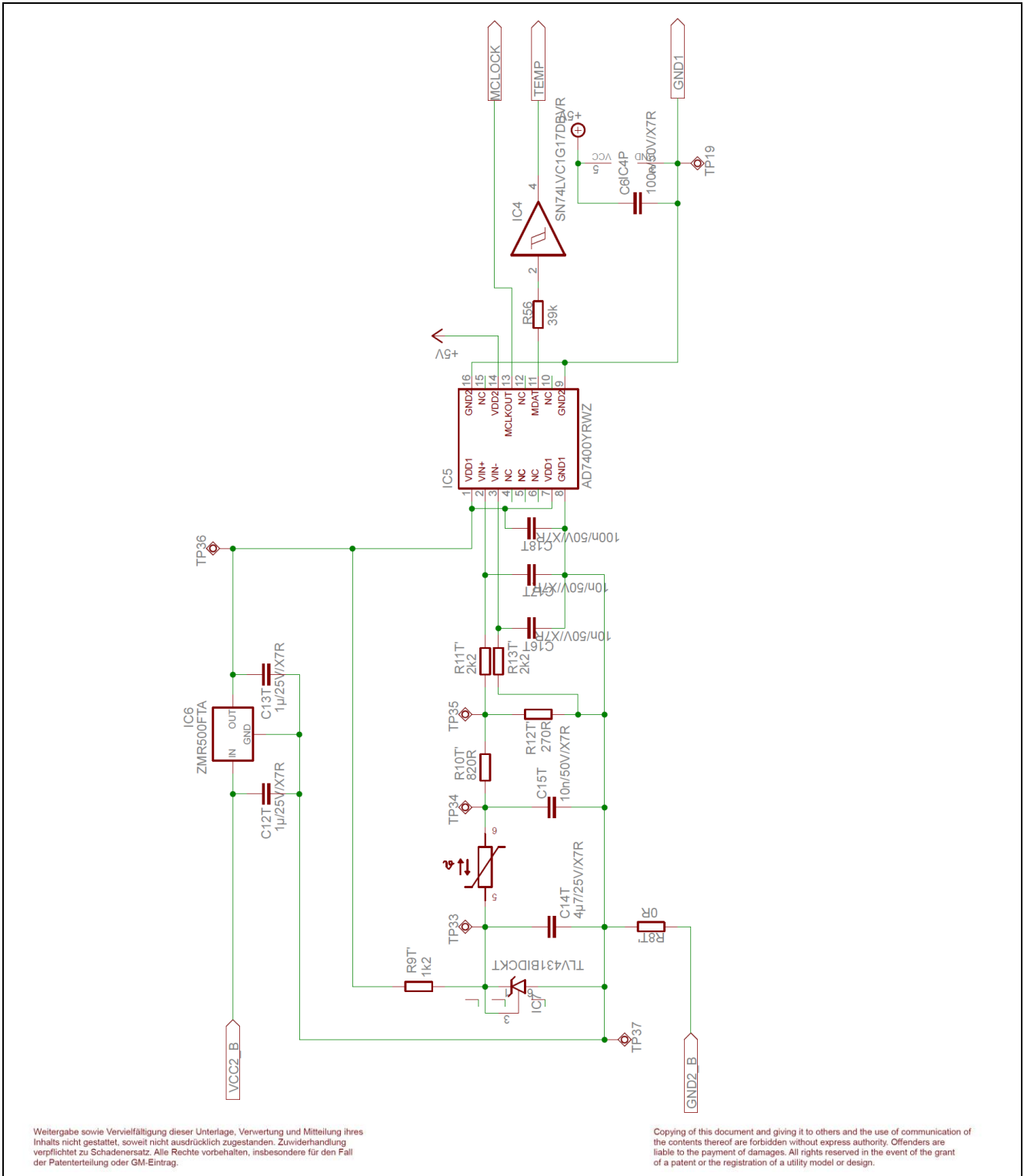
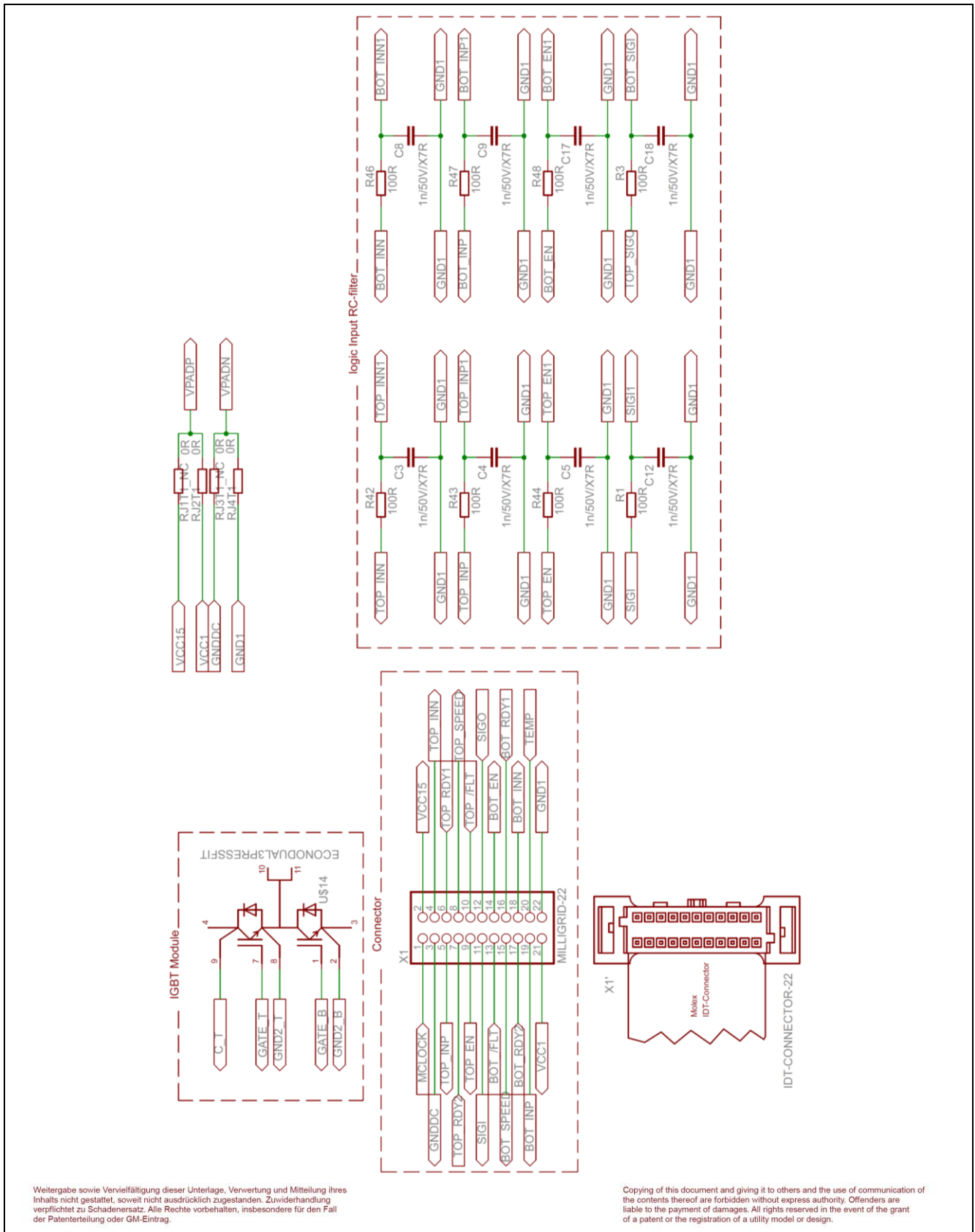

Figure 11 Schematic of isolated NTC measurement signal



Weitergabe sowie Vervielfältigung dieser Unterlage, Verwertung und Mitteilung ihres Inhalts nicht gestattet, soweit nicht ausdrücklich zugestanden. Zuwiderhandlung verpflichtet zu Schadensersatz. Alle Rechte vorbehalten, insbesondere für den Fall der Patenterteilung oder GM-Eintrag.

Copying of this document and giving it to others and the use of communication of the contents thereof are forbidden without express authority. Offenders are liable to the payment of damages. All rights reserved in the event of the grant of a patent or the registration of a utility model or design.

Figure 13 Schematic of RC-filters and supply selector including connector

8 Layout

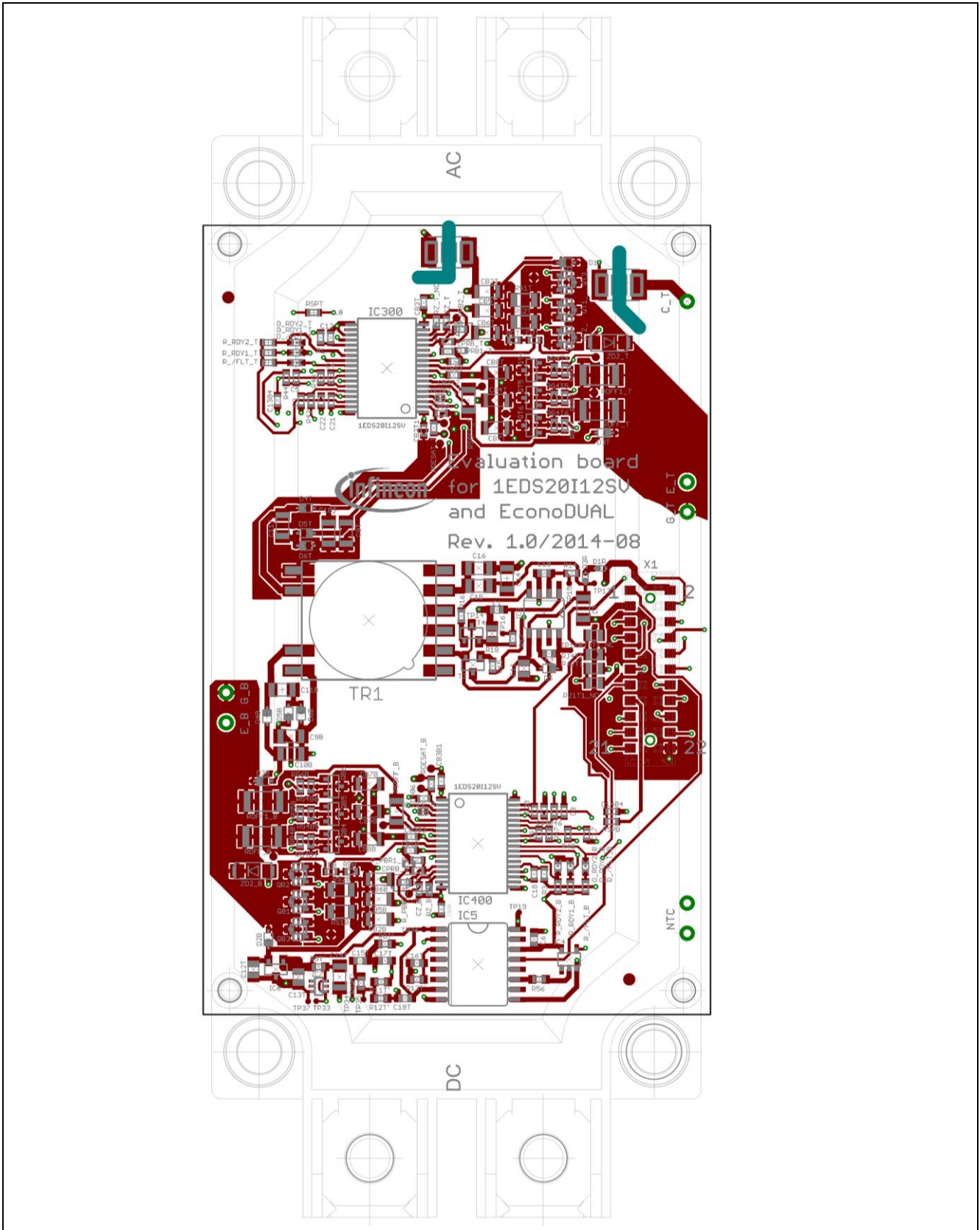

Figure 15 Top layer (thick green lines are milling trenches to achieve a larger creepage distance)

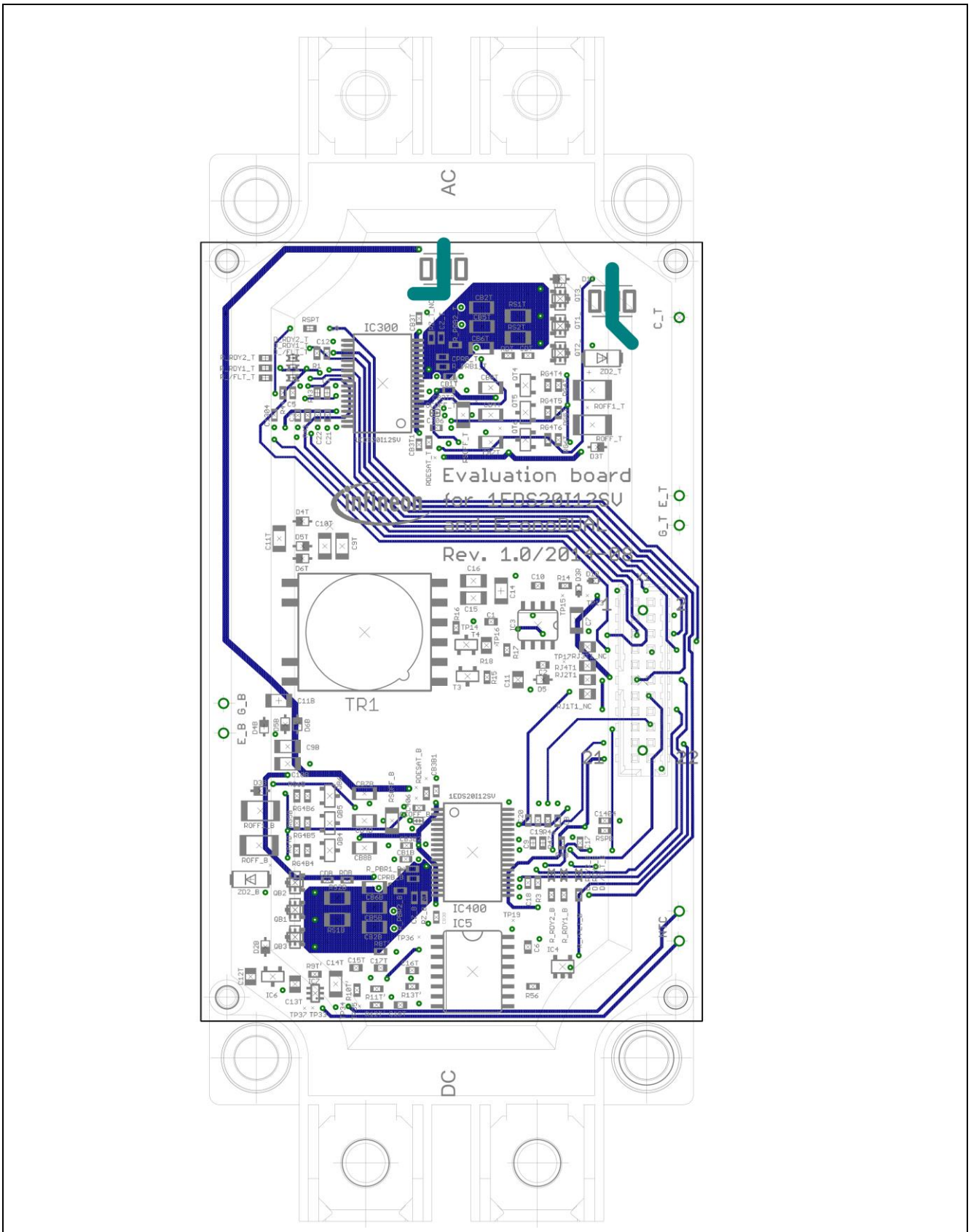

Figure 16 Inner layer 1

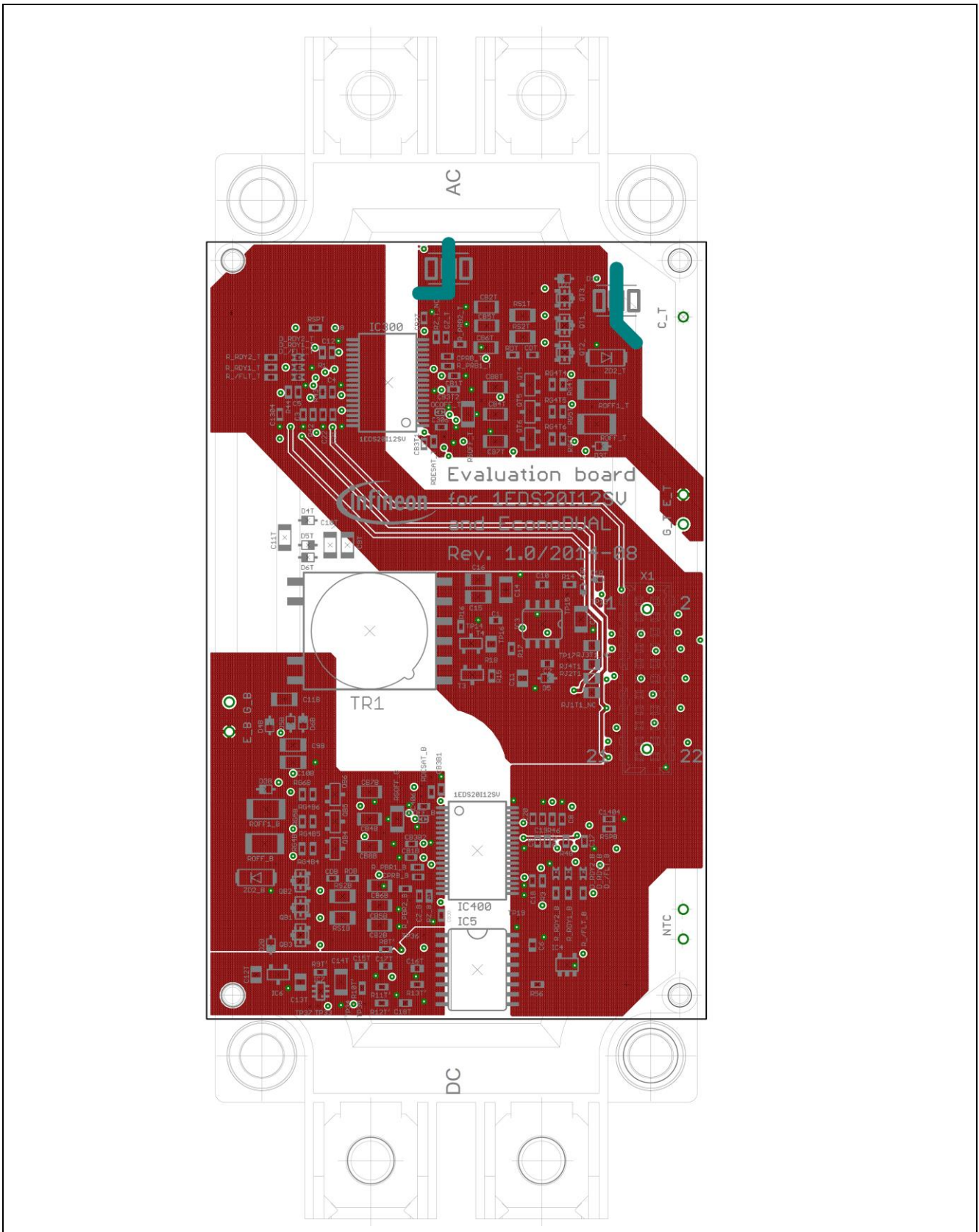

Figure 17 Inner layer 2

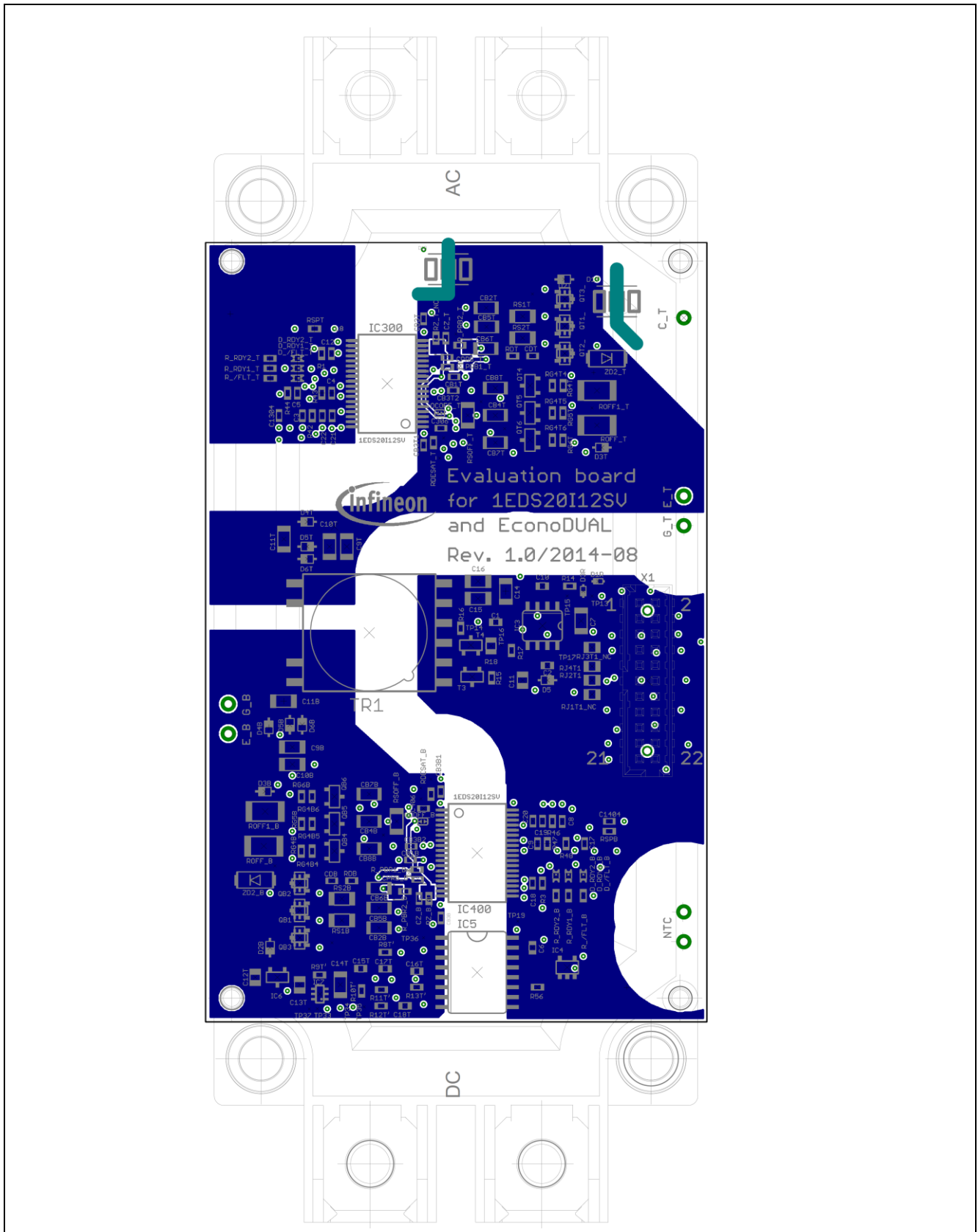

Figure 18 Bottom layer

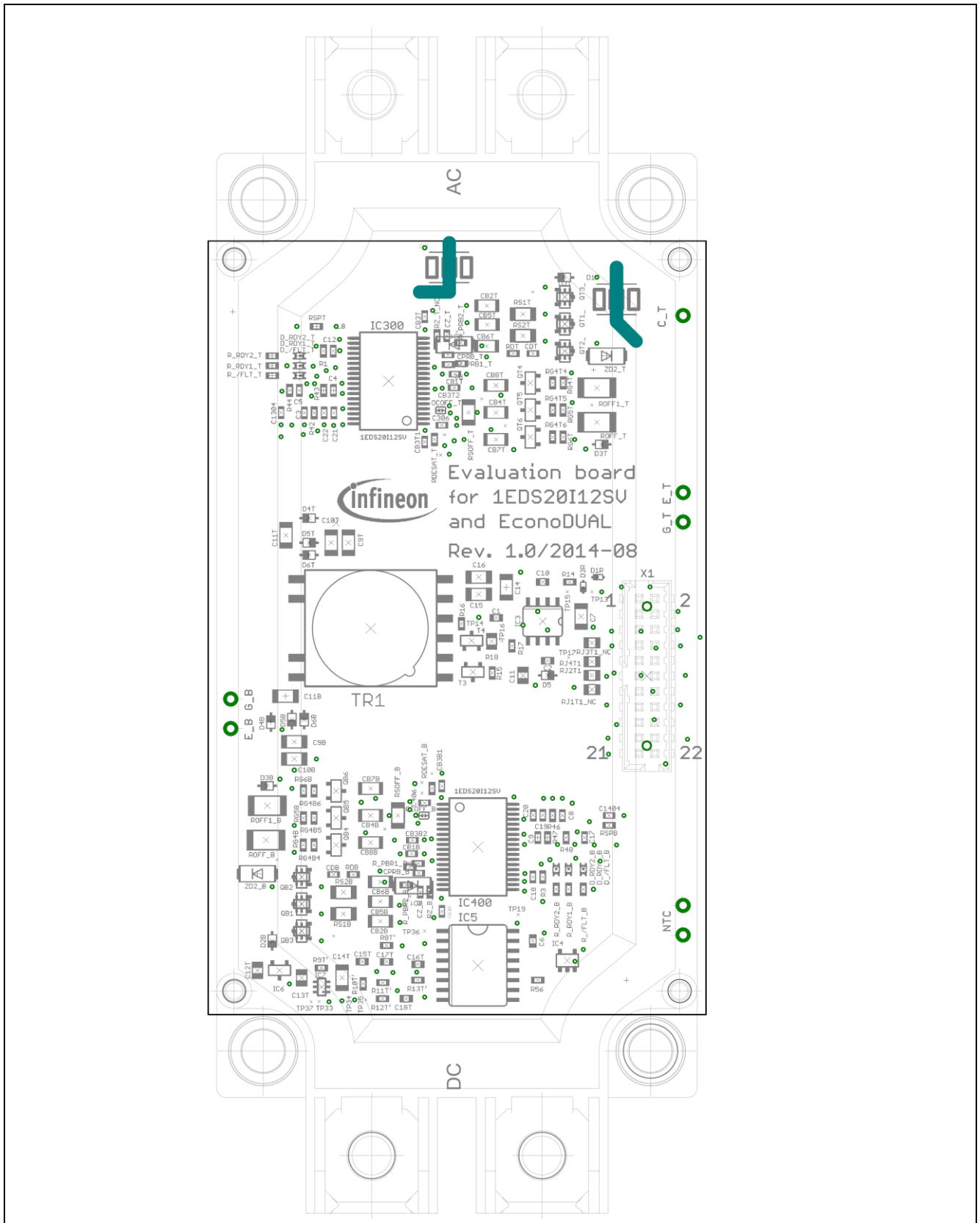

Figure 19 Assembly print

References

- [1] Infineon technologies: 1EDS20I12SV; datasheet rev 0.1, Infineon technologies, Germany, 2014
- [2] Infineon technologies: 1EDS20I12SV Technical description AN2014-01; application note rev 1.0, Infineon technologies, Germany, 2014
- [3] Infineon technologies: Assembly Instructions for the Easy-PressFIT Modules AN2009-01; application note rev 2.1, Infineon technologies, Germany, 2014

www.infineon.com

Published by Infineon Technologies AG

Mouser Electronics

Authorized Distributor

Click to View Pricing, Inventory, Delivery & Lifecycle Information:

[Infineon:](#)

[EVAL1EDS20I12SVTOBO2](#)