

*RoHS COMPLIANT

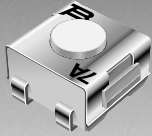

BOURNS®

Features

- Compatible with most surface mount soldering processes
- Compatible with popular vacuum pick-and-place equipment
- J-hook, gull-wing & pinned configurations
- Sealed for board washing
- Meets EIA/EIAJ/IPC/VRCI SMD standard outline dimensions
- Top or side actuated
- RoHS compliant*

7914 4 mm SMD & Through-hole Sealed Key Switch

Electrical Characteristics

Contact Rating
 Maximum Current100 mA max.
 Maximum Voltage16 V
 Contact Resistance100 milliohms max.
 Insulation Resistance ...100 megohms min.
 Dielectric Strength250 VAC

General Characteristics

Switch TypeNormally open
 Operating Temperature Range
-55 °C to +125 °C
 Storage Temperature Range
-55 °C to +125 °C
 Seal Test85 °C Fluorinert[†]
 Vibration20 G
 Shock100 G

Mechanical Characteristics

Actuator Force300 ± 100 g
 Pushover Strength (S Style)
2 kilograms minimum
 Cycle life, loaded100,000 actuations
 Contact resistance100 milliohms max.

Physical Characteristics

Cover MaterialStainless steel
 Base MaterialThermoplastic, UL94V-0
 Terminal MaterialPhosphor bronze
 Dome MaterialStainless steel
 Actuator MaterialHigh temperature
 silicon rubber
 MarkingManufacturer's code
 and date code

Packaging Options
 J & G500 pcs./reel; 50 pcs./tube
 S200 pcs./reel
 H50 pcs./tube

How to Order

7914 J - 1 - 000 E

Model _____
 Terminal _____
 J = J-Hook H = Through-hole
 G = Gull Wing S = Right Angle
 Switch Type _____
 1 = N.O. Au Contacts
 Product Code for Button Height
 (For Styles J, G and H)
 000 = 4.0 mm FMS
 024 = 2.4 mm FMS (Flush Actuator)
 032 = 3.2 mm FMS
 050 = 5.0 mm FMS (Tube packaging only)
 (For Style S)
 000 = 1.68 mm FTS
 032 = 0.91 mm FTS
 024 = Flush Actuator
 050 = 2.7 mm FTS
 Embossed Tape
 (Option applicable to Styles J, G and S only -
 Consult factory. Omit for Style J & G tube
 packaging.)
 G, J = 500 pcs./reel S = 200 pcs./reel

FMS = From Mounting Surface
 FTS = From Top Surface

Product Dimensions

**7914J
J-Hook**

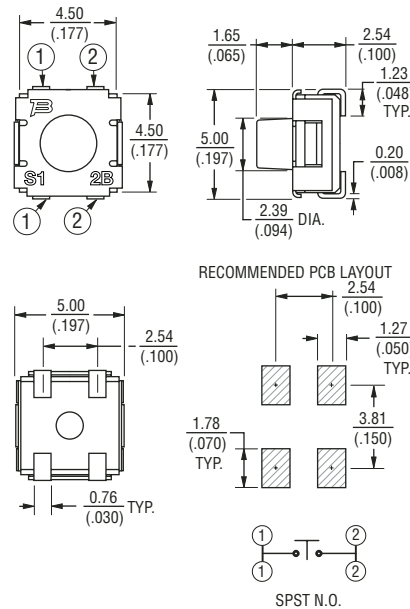

**7914H
Through-hole**

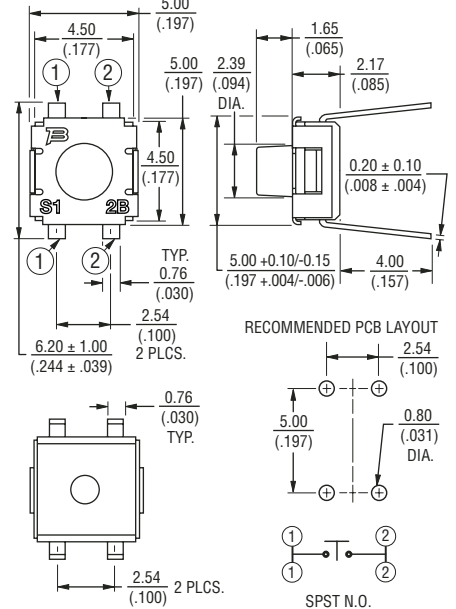

**7914G
Gull Wing**

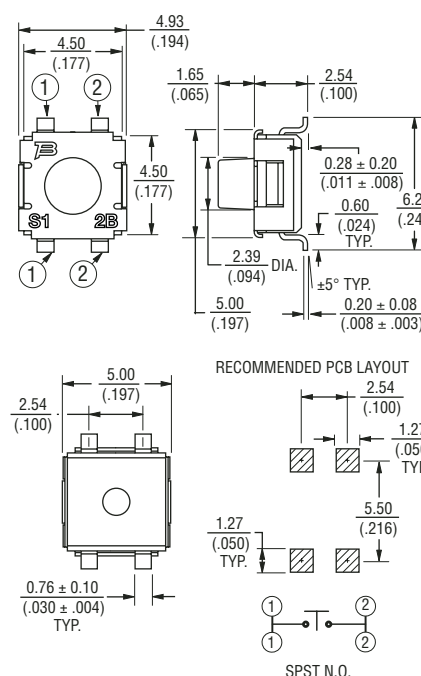

**7914S
Right Angle**

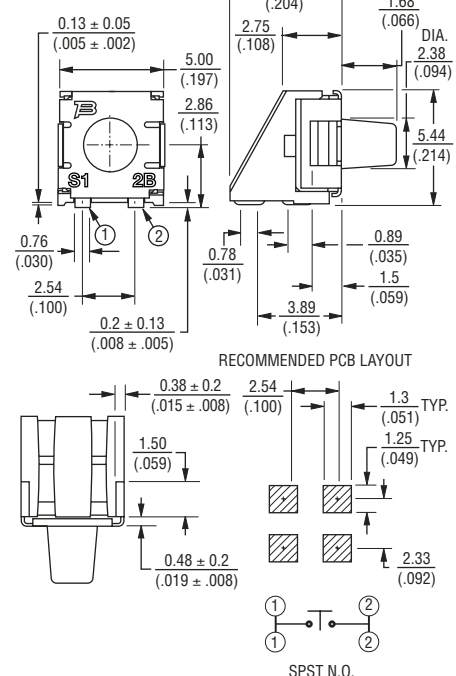

DIMENSIONS : $\frac{\text{MM}}{\text{(INCHES)}}$

TOLERANCES : $\frac{.02}{(.008)}$
 EXCEPT WHERE NOTED.

*RoHS Directive 2002/95/EC Jan 27 2003 including Annex.
[†]Fluorinert[™] is a registered trademark of 3M Co.
 Specifications are subject to change without notice.
 Customers should verify actual device performance in their specific applications.

7914 4 mm SMD & Through-hole Sealed Key Switch

BOURNS®

Packaging Specifications

7914J

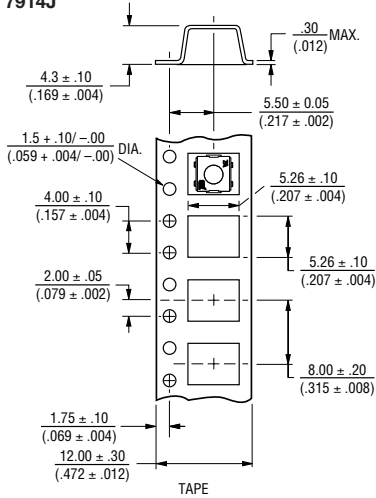

Meets EIA specification 481.

500 pcs./reel

7914J/G

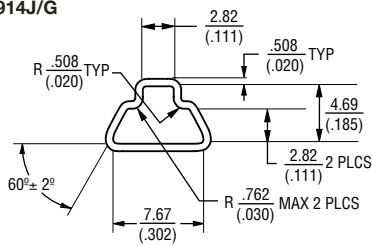

50 pcs./tube

7914G

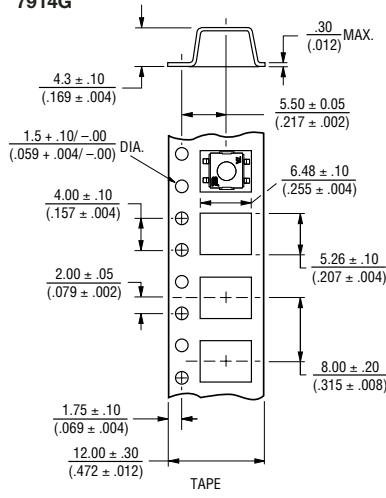

Meets EIA specification 481.

500 pcs./reel

7914H

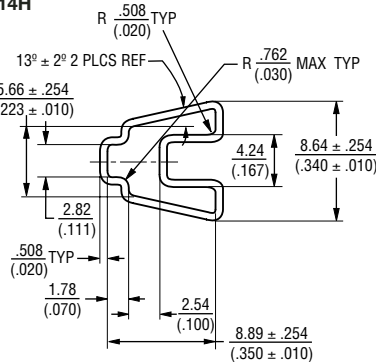

50 pcs./tube

7914S

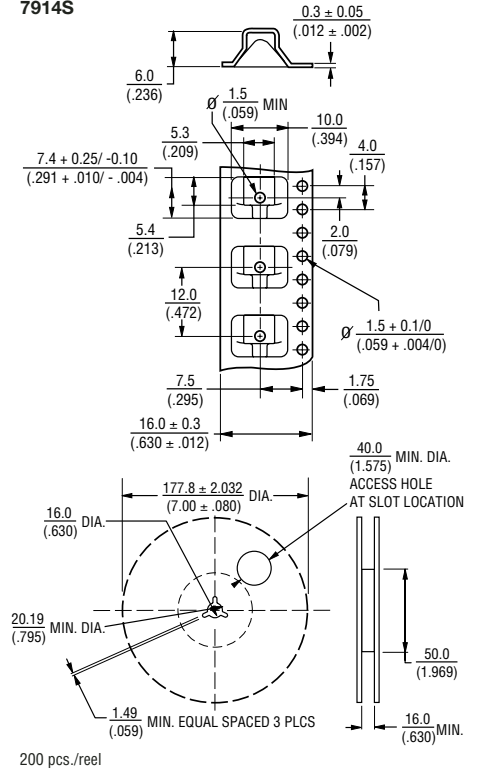

Reflow Soldering Profile

