

TABLE I

SHELL SIZE	A THREAD ISO METRIC	B DIA MAX	C DIA	D DIA	CRIMP RING	E DIA	T SHRINK BOOT
09	M12 X 1 - 6H	.650	.312	.365	GSC 425	.560	770-001S103
11	M15 X 1 - 6H	.777	.438	.500	GSC 59012	.670	770-001S103
13	M18 X 1 - 6H	.900	.562	.620	GSC 71012	.795	770-001S104
15	M22 X 1 - 6H	1.025	.688	.750	GSC 84012	.945	770-001S104
17	M25 X 1 - 6H	1.150	.812	.880	GSC 101012	1.060	770-001S105
19	M28 X 1 - 6H	1.275	.938	1.000	GSC 113012	1.170	770-001S106
21	M31 X 1 - 6H	1.400	1.040	1.120	GSC 125012	1.295	770-001S107
23	M34 X 1 - 6H	1.525	1.122	1.192	GSC 133212	1.420	770-001S107
25	M37 X 1 - 6H	1.650	1.224	1.294	GSC 144012	1.545	770-001S108

REVISIONS

SYM.	DESCRIPTION	DATE	APPROVED
A	REVISED PER DCN 05047	01/29/85	C.S.
B	REVISED PER DCN 06860	12/28/87	C.S.
C	REDRAWN & REVISED PER DCN 09198	04/19/91	V.N.
D	REVISED PER DCN 12834	11/01/96	T.L.
E	REVISED PER DCN 14102	09/03/98	T.L.
F	REVISED PER DCN 33911	10/21/09	T.L.
G	REVISED PER DCN 39426	07/15/11	J.S.
H	REVISED PER DCN 39740	09/22/11	N.D.
J	REVISED PER DCN 49400	01/22/14	T.G.
K	REVISED PER DCN 52151	09/11/14	N.D.

TABLE II

SYM	FINISH DESCRIPTION
B	CADMIUM PLATE/OLIVE DRAB
OMIT	ELECTROLESS NICKEL
N	CADMIUM PLATE/OLIVE DRAB OVER NICKEL PLATE
NF	CAD/O. D. OVER ELECTROLESS NICKEL (1000 HOUR SALT SPRAY)
Z1	300 SERIES SST/PASSIVATE
ZL	STAINLESS STEEL/NICKEL PLATE PER QQ-N-290
ZNU	BLACK ZINC NICKEL OVER ELECTROLESS NICKEL
SEE SHEET 2 OF STD-001 (COMMON ACCESSORY INTERFACE DATA) FOR ADDITIONAL PLATING SYMBOL	

PART NUMBER DEVELOPMENT

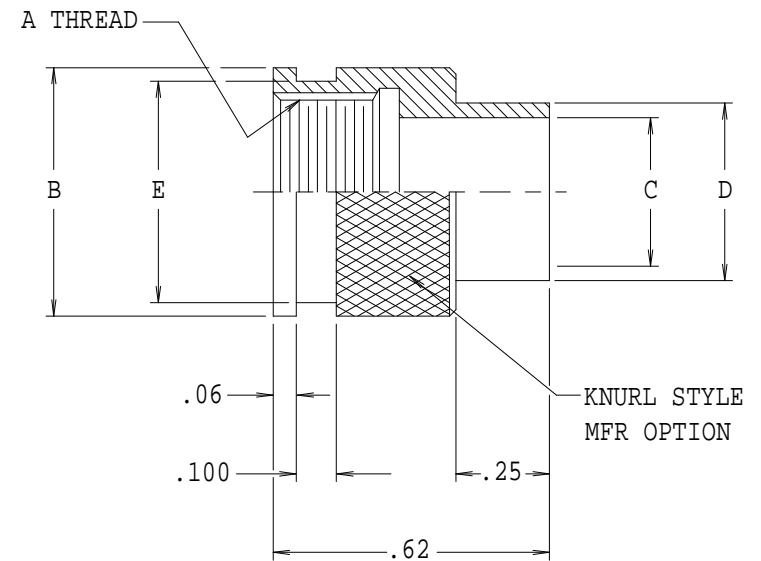
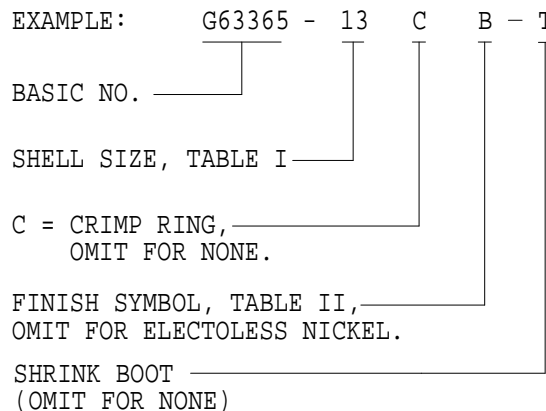

NOTES:

- ASSEMBLY IDENTIFIED WITH MANUFACTURERS NAME AND P/N, SPACE PERMITTING.
- FOR EFFECTIVE GROUNDING, CONNECTOR WITH CONDUCTIVE FINISH SHOULD BE USED.
- GLENAIR 600 SERIES BACKSHELL ASSEMBLY TOOLS ARE RECOMMENDED FOR ASSEMBLY AND INSTALLATION.
- MATERIAL/FINISH:
ADAPTER - SEE TABLE II.
CRIMP-RING - COPPER/TIN PLATE.

THIS COPYRIGHTED DOCUMENT IS THE PROPERTY OF GLENAIR, INC. AND IS FURNISHED ON THE CONDITION THAT IT IS NOT TO BE DISCLOSED, REPRODUCED IN WHOLE OR IN PART, OR USED TO SOLICIT QUOTATIONS FROM COMPETITIVE SOURCES, OR USED FOR MANUFACTURE BY ANYONE OTHER THAN GLENAIR, INC. WITHOUT WRITTEN PERMISSION FROM GLENAIR, INC. THE INFORMATION HEREIN HAS BEEN DEVELOPED AT GLENAIR'S EXPENSE AND MAY BE USED FOR ENGINEERING EVALUATION AND INCORPORATION INTO TECHNICAL SPECIFICATIONS AND OTHER DOCUMENTS WHICH SPECIFY PROCUREMENT OF PRODUCTS FROM GLENAIR, INC.

UNLESS OTHERWISE SPECIFIED	DRAWN	V. NGUYEN	04/19/91	GLENAIR, INC. CAD 1991 © 1211 AIR WAY • GLENDALE, CALIF. 91201		
	CHECK	G. BURGE	04/19/91			
	ENGR	P. OAKES	04/19/91			
DIMENSIONS ARE IN INCHES TOLERANCES: FRACTIONS ± 1/16 DECIMALS .XX ± .03 .XXX ± .015 ANGLES ± 2°				ADAPTER, CRIMP RING, FOR MIL-DTL-38999, SERIES III & IV CONNECTORS.		
DO NOT SCALE THIS DRAWING						
B/F91-6269 P/C 44						
RELEASE DATE		04/19/91		CODE IDENT. NO.	SIZE	REV.
ORIGINAL RELEASE DATE		12/03/84		06324	B	K
SCALE		N/A		WEIGHT	SHEET 1 OF 1	
				N/A		

Mouser Electronics

Authorized Distributor

Click to View Pricing, Inventory, Delivery & Lifecycle Information:

Glenair:

[G63365-15NF-326](#) [G63365-17NF](#) [G63365-15NF](#) [G63365-15](#) [G63365-9NF-326](#) [G63365-13](#) [G63365-23NF-326](#)
[G63365-23NF](#) [G63365-25NF](#) [G63365-9NF](#) [G63365-21NF-326](#) [G63365-13Z1-49](#) [G63365-13Z1](#) [G63365-17](#)
[G63365-25NF-326](#) [G63365-9Z1](#) [G63365-19NF-326](#) [G63365-11NF-326](#) [G63365-9B](#) [G63365-11CZ1](#) [G63365-11](#)
[G63365-25](#) [G63365-11NF](#) [G63365-13NF-326](#) [G63365-15Z1](#) [G63365-9](#) [G63365-17NF-326](#) [G63365-25CB](#) [G63365-](#)
[19NF](#) [G63365-13NF](#) [G63365-11Z1-49](#) [G63365-21NF](#) [G63365-09CZ1](#) [G63365-13CZ1](#) [G63365-19CZ1](#) [G63365-](#)
[19Z1](#) [G63365-09NF-326](#)