

1



XUZ B2003



XUZ M2003



XUZ K2003



XUZ X2003



XUZ M2004



XUZ K2004

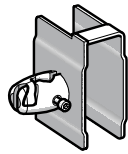

XUZ X2004



XUZ 2003



XUZ 2001

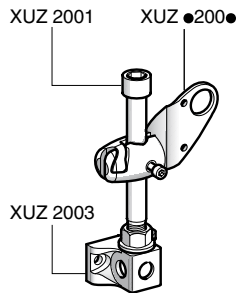

3D fixing kit example



XUZ A118

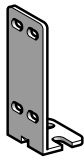

XUZ A50



XUZ A51

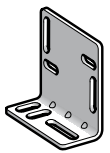

XUZ X2000

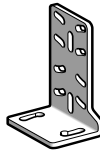

XUL Z41

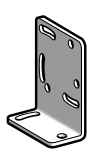

XUZ A41

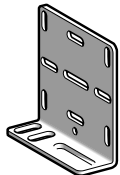

XUZ A49



XUZ A218

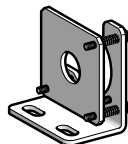

XUZ A318



XSA Z1●●



XSZ B1●●



XUZ B2005

3D fixing kit (1)

Description	For use with sensor type	Reference	Weight kg
Ball-joint mounted fixing bracket for mounting on M12 rod	XUB or XUZ C50	XUZ B2003	0.170
	XUM or XUZ C50	XUZ M2003	0.140
	XUK or XUZ C50	XUZ K2003	0.170
	XUX or XUZ C50	XUZ X2003	0.220
Ball-joint mounted fixing bracket with protective cover for mounting on M12 rod	XUM	XUZ M2004	0.155
	XUK	XUZ K2004	0.270
	XUX	XUZ X2004	0.420
Support for M12 rod	–	XUZ 2003	0.150
M12 rod (adjustment possible over complete height)	–	XUZ 2001	0.050

(1) To obtain a 3D fixing kit, order:

- rod support **XUZ 2003**
- M12 rod **XUZ 2001**
- ball-joint mounted fixing bracket **XUZ ●200●**

Fixing accessories

Description	For use with sensor type	Reference	Weight kg	
Stainless steel fixing bracket	XUB	XUZ A118	0.045	
Metal fixing brackets	XUM	XUZ A50	0.025	
	XUK	XUZ A51	0.050	
	XUX	XUZ X2000	0.065	
	XUL	XUL Z41	0.050	
	XUJ	XUZ A41	0.050	
	XUJ B	XUZ A49	0.120	
Plastic fixing bracket with adjustable ball-joint	XU● (Ø 18 mm)	XUZ A218	0.035	
Precision fixing bracket with micrometric adjustment	XU2 (Ø 18 mm) with laser transmission	XUZ A318	0.170	
Plastic fixing clamps with locking screw	XUA (Ø 8 mm)	XSA Z108	0.007	
	XU● (Ø 18 mm)	With lug	XSA Z118	0.020
		With indexing pin	XSZ B118	0.010
		With 24.1 mm ctrs.	XUZ B2005	0.007
Glass fibre optics XUF S0810	XSA Z145	0.005		
Fibre optics XUF S2510	XSA Z155	0.005		
Fibre optics XUF S0210	XSA Z185	0.005		
Set of 2 plastic nuts	XU● (Ø 18 mm)	XSA Z318	0.004	
Set of 2 metal nuts	XU● (Ø 18 mm)	XSZ E118	0.015	
Set of 2 stainless steel nuts	XU● (Ø 18 mm)	XSZ E318	0.015	



XUZ C●●

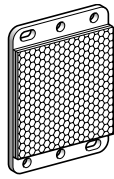

XUZ C50

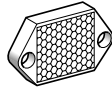

XUZ C24

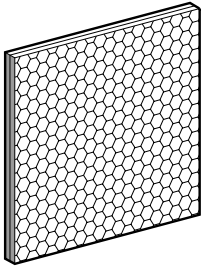

XUZ C100

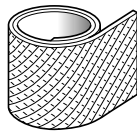

XUZ B0●

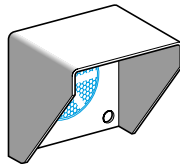

XUZ D15

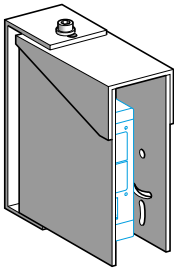

XUZ D25

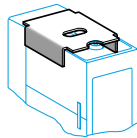

XUJ Z01



XUZ X2001



XUR Z01

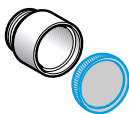

XUR Z02

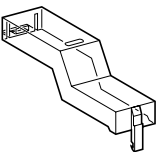

XUV Z02

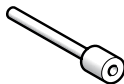

XUF Z08

Reflectors

Description	Dimensions (mm)	Length (m)	Reference	Weight kg
Standard reflectors	Ø 16	–	XUZ C16	0.002
	Ø 21	–	XUZ C21	0.002
	Ø 31	–	XUZ C31	0.005
	Ø 39	–	XUZ C39	0.008
	Ø 80	–	XUZ C80	0.029
Universal reflector (without blind zone)	50 x 50	–	XUZ C50	0.020
Reflector for short sensing distances	24 x 21	–	XUZ C24	0.007
Reflector for long sensing distances	100 x 100	–	XUZ C100	0.062
Standard reflective adhesive tape (1)	Width: 22	1	XUZ B01	0.015
	Thickness: 0.4	5	XUZ B05	0.075
Reflective adhesive tape (1) (specifically for polarised reflex systems and Osiconcept)	Width: 22	1	XUZ B11	0.020
	Thickness: 0.4	5	XUZ B15	0.085

Protective covers

Description	For use with	Reference	Weight kg
Protective covers	Sensors XUX and XUJ	XUZ D25	0.920
	Reflectors XUZ C80 or XUZ C24	XUZ D15	0.270
Potentiometer protective cover	Sensors XUJ	XUJ Z01	0.015

Cabling accessories

Description	Reference	Weight kg
Adaptor, ISO 16 - 1/2" NPT	XUZ X2001	0.050
Adaptor, ISO 16 - ISO 20	XUZ X2002	0.050

Lenses

Description	For use with	Reference	Weight kg
Lens for spot enlargement	Sensors XUR	XUR Z01	0.010
Lens accessory for spot reduction	Sensors XUR	XUR Z02	0.015

Spare parts

Description	For use with	Sold in lots of	Unit reference	Weight kg
Plastic end adaptor for connecting Ø 1 mm fibres	Amplifiers XUDA	2	XUF Z08	0.002
Transparent covers	Sensors XUV	–	XUV Z02	0.003

Protection fuses

Description	For use with	Sold in lots of	Unit reference	Weight kg
Cartridge fuse 5 x 20 0.4 A "quick-blow"	Sensors without short-circuit protection	10	XUZ E04	0.001
Fuse terminal block	Cartridge fuses XUZ E0●	50	AB1 FU10135U	0.040

(1) Suitable for use at maximum ambient temperature of + 50 °C.

1

XUZ B2003

Ball-joint mounted fixing bracket for XUB or XUZ C50

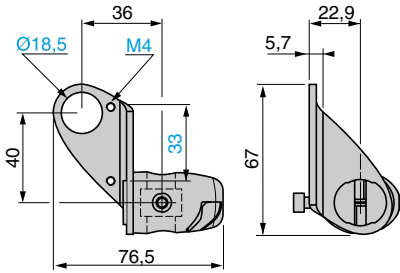

XUZ 2001

M12 rod

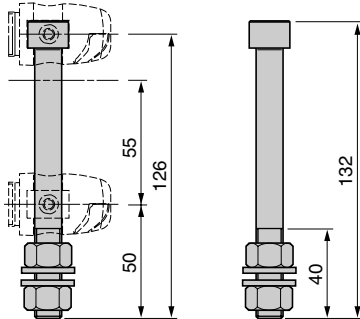

XUZ 2003

Support for M12 rod

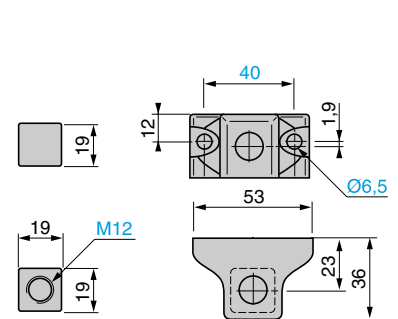

XUZ M2003

Ball-joint mounted fixing bracket for XUM (1) or XUZ C50

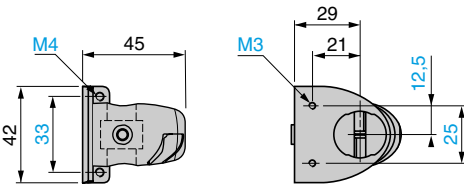

XUZ M2004

Ball-joint mounted fixing bracket with protective cover for XUM (1)

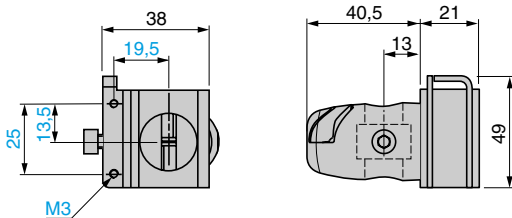

XUZ K2003

Ball-joint mounted fixing bracket for XUK (1) or XUZ C50

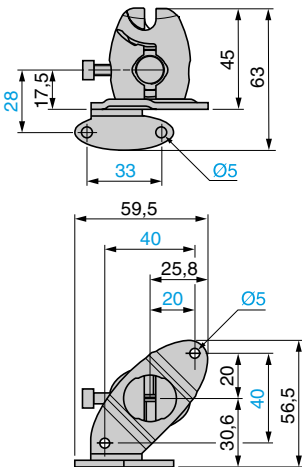

XUZ K2004

Ball-joint mounted fixing bracket with protective cover for XUK (1)

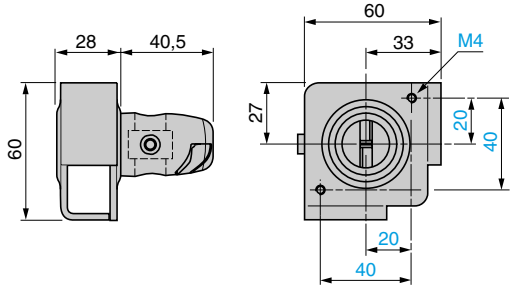

XUZ X2003

Ball-joint mounted fixing bracket for XUX (1) or XUZ C50

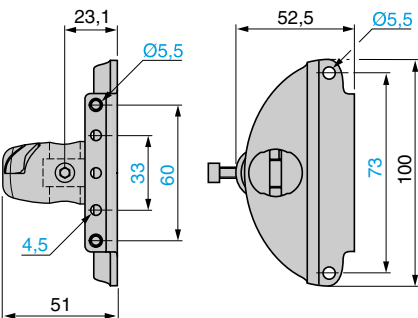

XUZ X2004

Ball-joint mounted fixing bracket with protective cover for XUX (1)

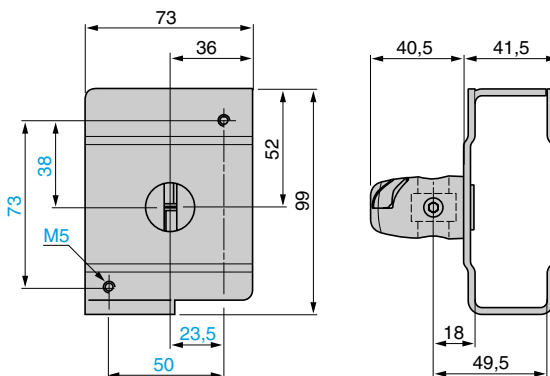

(1) Accessory fixing screws included.

XUZ B2003 + XUZ 2001 + XUZ 2003

3D fixing kit for XUB or reflector XUZ C50

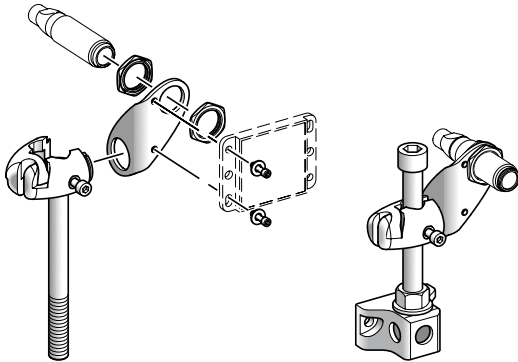

XUZ 2001 + XUZ 2003

M12 rod + rod support

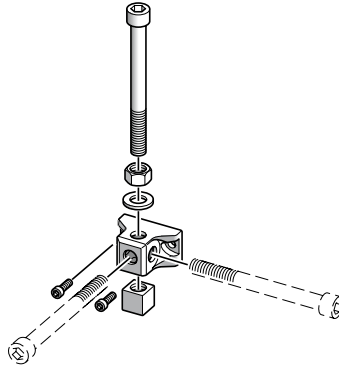

XUZ M2003 + XUZ 2001

3D fixing kit for XUM or reflector XUZ C50

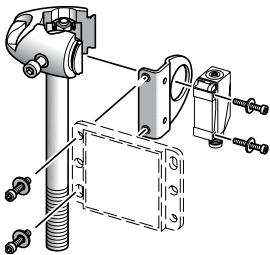

XUZ M2004 + XUZ 2001

3D fixing kit with protective cover for XUM

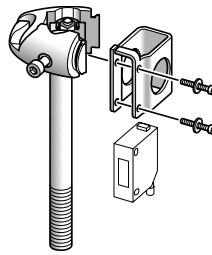

XUZ K2003 + XUZ 2001

3D fixing kit for XUK or reflector XUZ C50

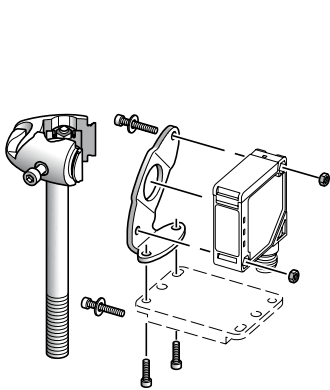

XUZ K2004 + XUZ 2001 + XUZ 2003

3D fixing kit with protective cover for XUK

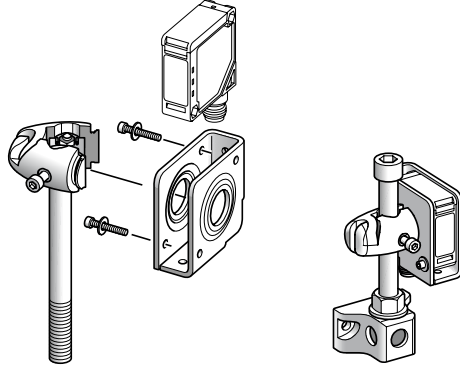

Mounting example

XUZ X2003 + XUZ 2001

3D fixing kit for XUX or reflector XUZ C50

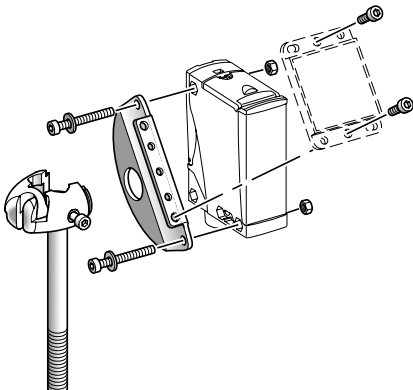

XUZ X2004 + XUZ 2001

3D fixing kit with protective cover for XUX

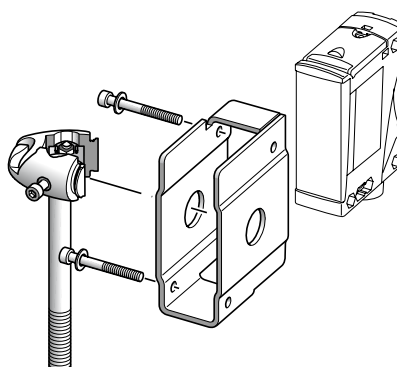

1

XUZ A118

Fixing bracket XUB

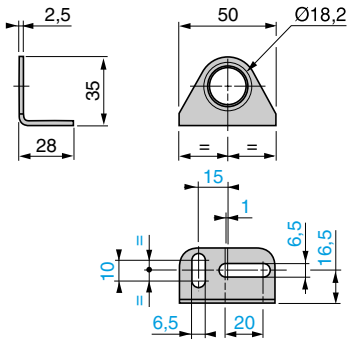

XUZ A218

Fixing bracket with adjustable ball-joint for XU● (Ø 18)

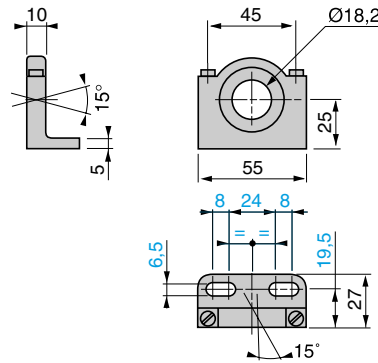

XUZ A50

Fixing bracket XUM (2)

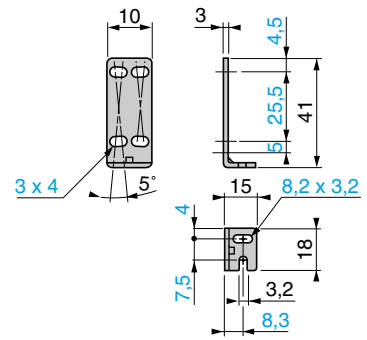

XUZ A51

Fixing bracket for XUK (2)

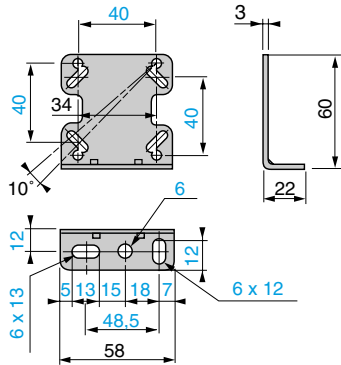

XUZ X2000

Fixing bracket for XUX (2)

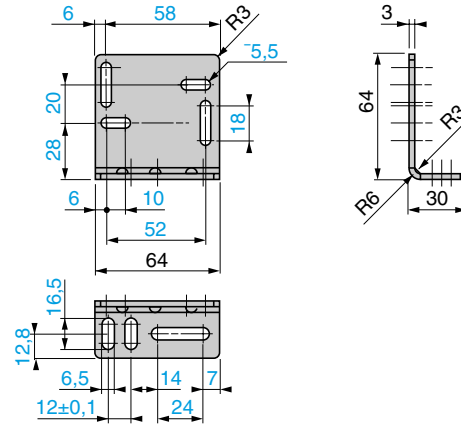

XUZ A318

Fixing bracket with micrometric adjustment for XU2 (Ø 18) with laser transmission

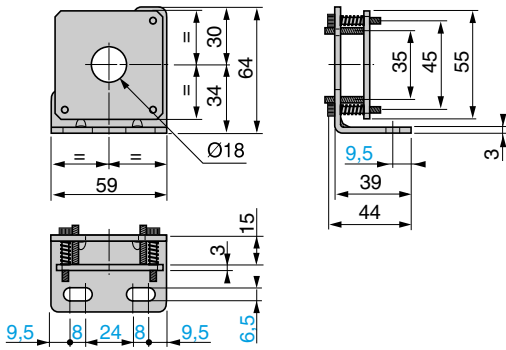

XSZ B108, XSZ B118

Fixing clamps for XUA and XU● (Ø 18)

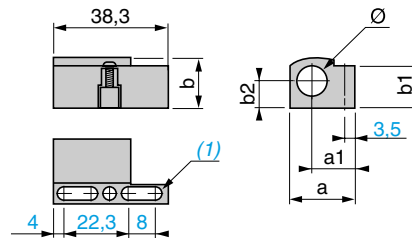

XCZ	a	a1	b	b1	b2	Ø
B108	21.1	14.5	14.2	12.8	7.5	8
B118	26	15.7	22.3	20.1	11.5	18

(1) 2 elongated holes Ø 4 x 8.

XUZ B2005

Fixing clamps with 24.1 mm centres for XU● (Ø 18)

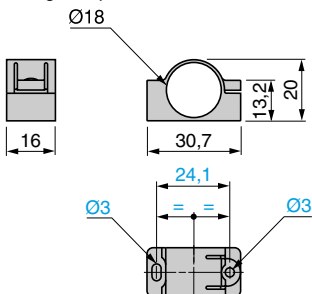

XSA Z1●●

Fixing clamps for XUA, XU● (Ø 18), XUF

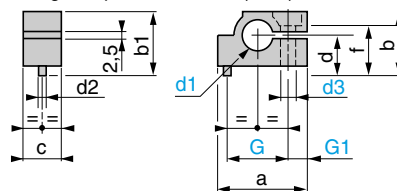

XSA	a	b	b1	c	d	Ød1	Ød2	Ød3	f	G	G1
Z108	23.5	14.2	16.7	10	8	8.1	2	4	10.5	16	5
Z118	41	30	33	17	18	18.1	3.9	6	24	30	7
Z145	23.5	14.2	16.7	10	8	4.7	2	4	10.5	16	5
Z155	23.5	14.2	16.7	10	8	5.7	2	4	10.5	16	5
Z185	23.5	14.2	16.7	10	8	8.6	2	4	10.5	16	5

(2) Accessory fixing screws included.

XUZ D15

Protective cover for XUZ C80 or XUZ C24

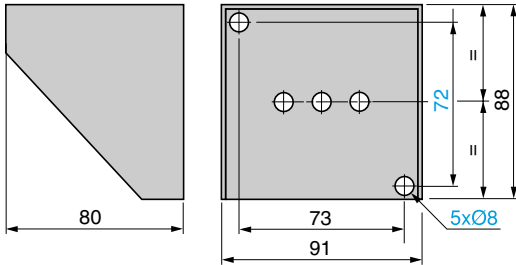

XUZ D25

Protective cover for XUX or XUJ

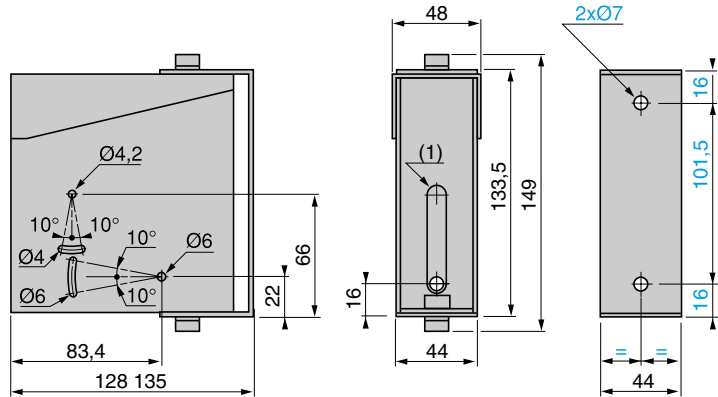

XUZ C●●

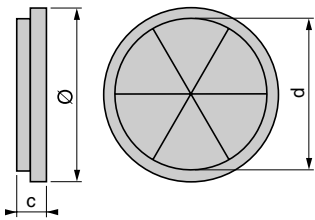

XUZ	Ø	c	d
C16	21	5.5	17
C21	25.5	6	20.5
C31	35	7.5	30.5
C39	46	6.5	37

XUZ C50

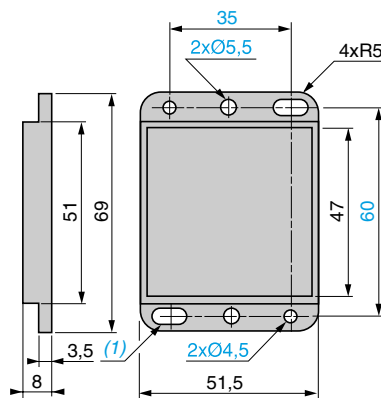

(1) 2 elongated holes Ø 4.5 x 8.

XUZ M2003 + XUZ 2001 + XUZ 2003 + XUZ C50

Mounting example

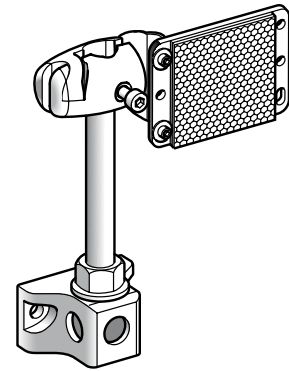

XUZ C24

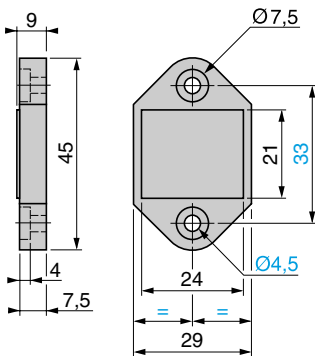

XUZ C100

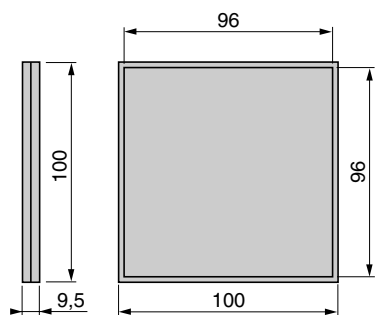

XUZ X2001

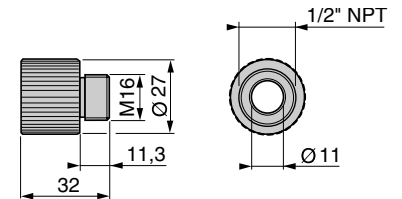

XUZ C80

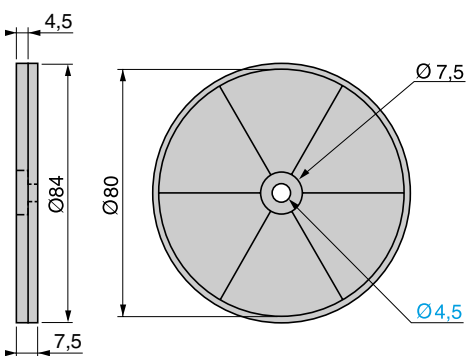

XUZ X2002

