

**CONNECTOR DESIGNATORS**  
**A-F-H-L-S**  
**SELF-LOCKING**  
**ROTATABLE**  
**COUPLING**

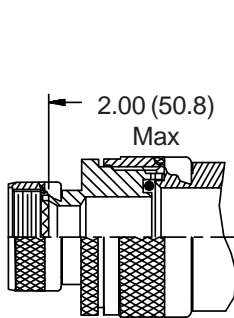

**STYLE 2**  
**(STRAIGHT**  
 See Note 5)

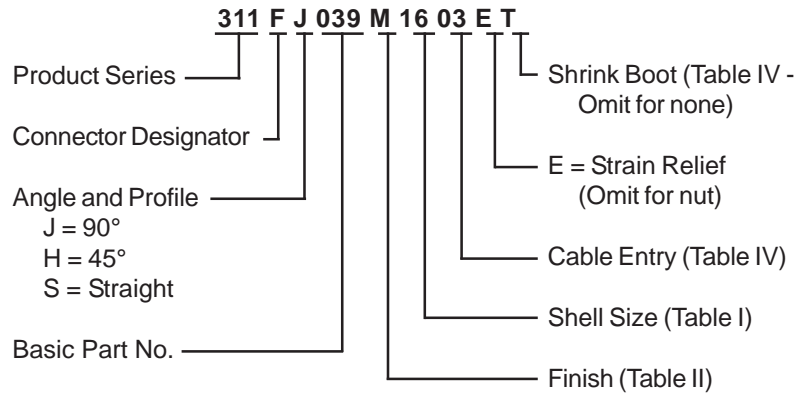
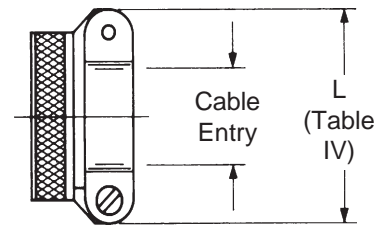
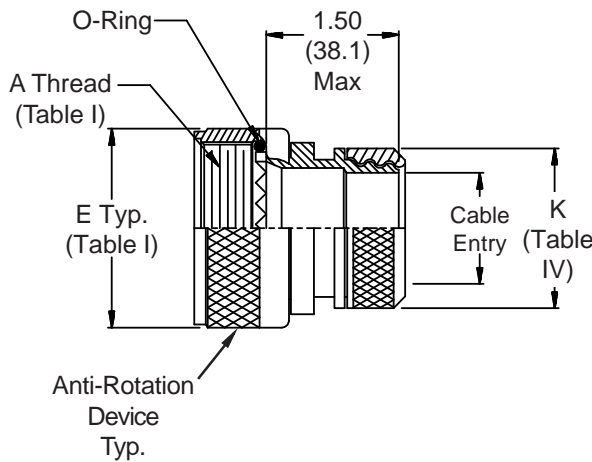

**STYLE E**  
**STRAIN RELIEF**

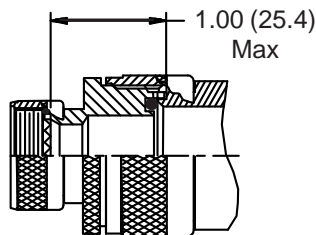

**STYLE 2**  
**(45° & 90°**  
 See Note 5)

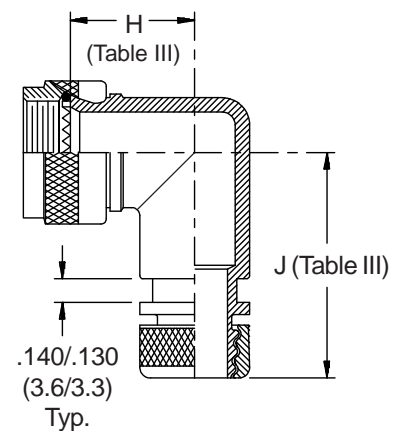
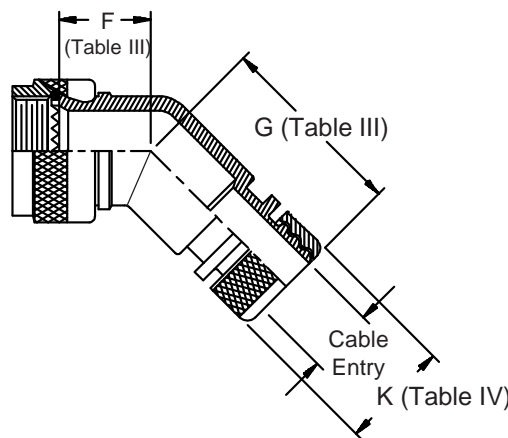

See inside back cover fold-out  
or pages 13 and 14  
for Tables I and II.

TABLE III: DIMENSIONS						
SHELL SIZE		F	G	H	J	
A-F-L-S	H	Max	Max	Max	Max	
08	09	.795 (20.2)	1.045 (26.5)	.906 (23.0)	1.155 (29.3)	
10	11	.820 (20.8)	1.075 (27.3)	.966 (24.5)	1.225 (31.1)	
12	13	.844 (21.4)	1.097 (27.9)	1.026 (26.1)	1.285 (32.6)	
14	15	.861 (21.9)	1.125 (28.6)	1.076 (27.3)	1.345 (34.2)	
16	17	.888 (22.6)	1.145 (29.1)	1.136 (28.9)	1.405 (35.7)	
18	19	.904 (23.0)	1.165 (29.6)	1.176 (29.9)	1.455 (37.0)	
20	21	.929 (23.6)	1.195 (30.4)	1.236 (31.4)	1.525 (38.7)	
22	23	.956 (24.3)	1.215 (30.9)	1.296 (32.9)	1.575 (40.0)	
24	25	.979 (24.9)	1.245 (31.6)	1.356 (34.4)	1.645 (41.8)	

TABLE IV: CABLE ENTRY/DIMENSIONS/SHRINK BOOT					
Dash No.	K Max	L Max	Cable Entry Max	Shrink Boot	
01	.448 (11.4)	.781 (19.8)	.125 (3.2)	770-003S111	
02	.515 (13.1)	.968 (24.6)	.250 (6.4)	770-003S112	
03	.640 (16.3)	1.046 (26.6)	.375 (9.5)	770-003S103	
04	.765 (19.4)	1.156 (29.4)	.500 (12.7)	770-001S103	
05	.920 (23.4)	1.219 (31.0)	.625 (15.9)	770-001S104	
06	1.015 (25.8)	1.343 (34.1)	.750 (19.1)	770-001S104	
07	1.140 (29.0)	1.469 (37.3)	.875 (22.2)	770-001S105	
08	1.265 (32.1)	1.594 (40.5)	1.000 (25.4)	770-001S106	
09	1.432 (36.4)	1.719 (43.7)	1.125 (28.6)	770-001S107	

1. Cable Entry is defined as the accomodation range for the wire bundle or cable. Dimensions shown are not intended for inspection criteria.
2. See Shrink Boot Reference Information (page 40).
3. Metric dimensions (mm) are indicated in parentheses.
4. O-Ring not supplied with Connector Designator A.
5. When maximum entry (page 21) is exceeded, Style 2 will be supplied. Dimensions F, G, H & J will not apply. Please consult factory.

TABLE II - STANDARD FINISHES	
GLENAIR SYMBOL	FINISH
B	Cadmium Plate, Olive Drab
M	Electroless Nickel
NF	Cadmium Plate, Olive Drab Over Electroless Nickel
See Inside Back Cover for Complete Finish Information and Additional Finish Options	

# Mouser Electronics

Authorized Distributor

Click to View Pricing, Inventory, Delivery & Lifecycle Information:

## Glenair:

[311HS039NF1504](#) [311HS039NF1904](#) [311AS039NF1004](#) [311AS039NF1404](#) [311AS039NF1605](#) [311AS057XM1202](#)  
[311AS039M2003](#) [311AS039NF1403E](#) [311AS039NF2205](#) [311HJ039NF1704](#) [311HS039NF1103](#) [311HS039M1909E](#)  
[311HS039M2309E](#) [311HS039N2105](#)