



**620-048**  
**Strain Relief**  
**Self-Locking Rotatable Coupling - Straight and 90°**

**CONNECTOR  
DESIGNATOR**

MIL-DTL-38999 Series I, II (F)  
MIL-DTL-38999 Series III and IV (H)

**F-H**

**SELF-LOCKING  
ROTATABLE  
COUPLING**

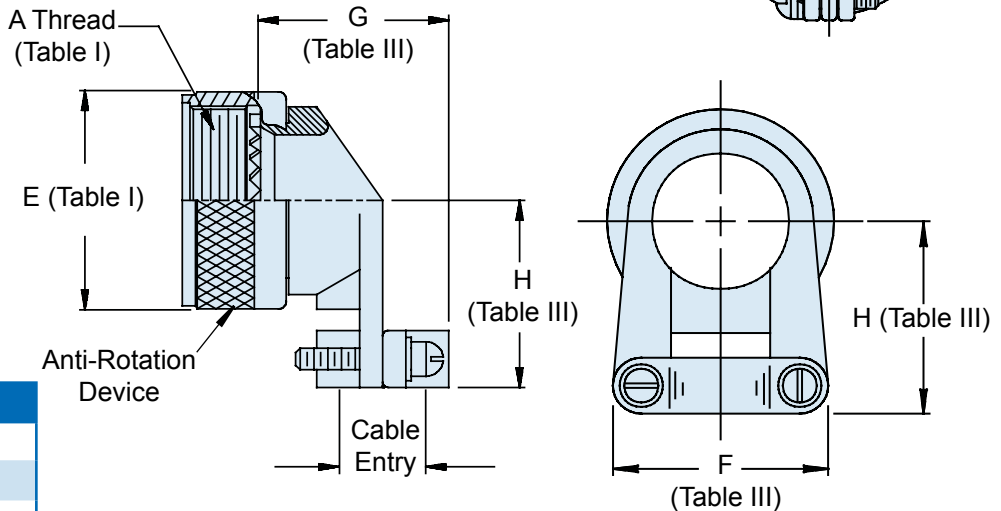
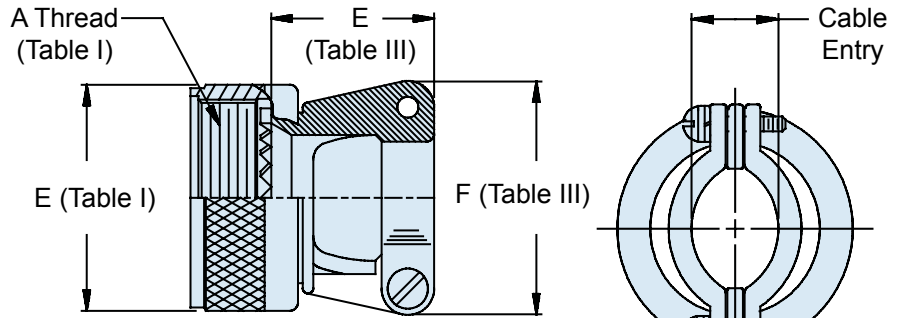
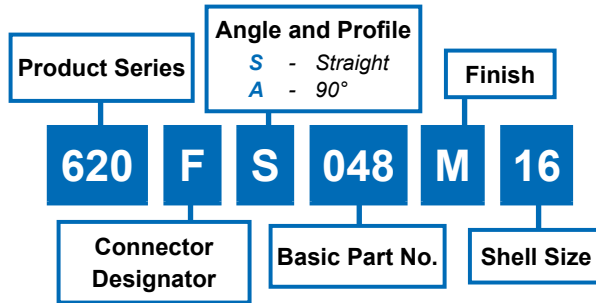

**APPLICATION NOTES**

1. Cable range is defined as the accommodation range for the wire bundle or cable. Dimensions shown are not intended for inspection criteria.
2. Metric dimensions (mm) are indicated in parentheses.

**TABLE II: FINISHES**

Symbol	Finish
B	Cadmium Plate, Olive Drab
C	Anodize, Black
G	Hard Coat, Anodic
GB	Black Anodize, Hard Coat
M	Electroless Nickel
N	Cad Plate, Olive Drab over Electroless Nickel
NF	Cadmium Plate, Olive Drab over Electroless Nickel
MT	Nickel Fluorocarbon Polymer
Z1	Stainless Steel Passivate
ZN	Zinc-Nickel

**TABLE III: CABLE ENTRY**

Shell Size	Cable Range		G Max	H Max	Cable Range Closed	Cable Range Open
	E Max	F Max				
08/09	.830 (21.1)	.780 (19.8)	.704 (17.9)	.808 (20.5)	.098 (2.5)	.234 (5.9)
10/11	.850 (21.6)	.832 (21.1)	.786 (20.0)	.867 (22.0)	.153 (3.9)	.234 (5.9)
12/13	.900 (22.9)	.988 (25.1)	.979 (24.9)	.929 (23.6)	.190 (4.8)	.328 (8.3)
14/15	.900 (22.9)	1.046 (26.6)	1.039 (26.4)	.992 (25.2)	.260 (6.6)	.457 (11.6)
16/17	.940 (23.9)	1.319 (33.5)	1.188 (30.2)	1.056 (26.8)	.283 (7.2)	.614 (15.6)
18/19	1.020 (25.9)	1.451 (36.9)	1.300 (33.0)	1.233 (31.3)	.325 (8.3)	.634 (16.1)
20/21	1.070 (27.2)	1.557 (39.5)	1.425 (36.2)	1.296 (32.9)	.343 (8.7)	.698 (17.7)
22/23	1.190 (30.2)	1.653 (42.0)	1.550 (39.4)	1.358 (34.5)	.381 (9.7)	.823 (20.9)
24/25	1.220 (31.0)	1.775 (45.1)	1.675 (42.5)	1.420 (36.1)	.418 (10.6)	.853 (21.7)

# Mouser Electronics

Authorized Distributor

Click to View Pricing, Inventory, Delivery & Lifecycle Information:

## Glenair:

[620FS048M16](#) [620FS048M20](#) [620FS048NF16](#) [620FS048LF12](#) [620FS048M08](#) [620FS048M12](#) [620FS048M14](#)  
[620FS048M18](#) [620FS048N10](#) [620FS048N14](#) [620FS048N16](#) [620FS048NF12](#) [620FS048NF14](#) [620FS048M22](#)  
[620FS048M24](#) [620FS048N18](#) [620FS048NF08](#)