

APPROVED: _____
 DATE: _____ TITLE: _____

Rev	AWO #	Description	Date	Appr
-		RELEASED	11/26/18	

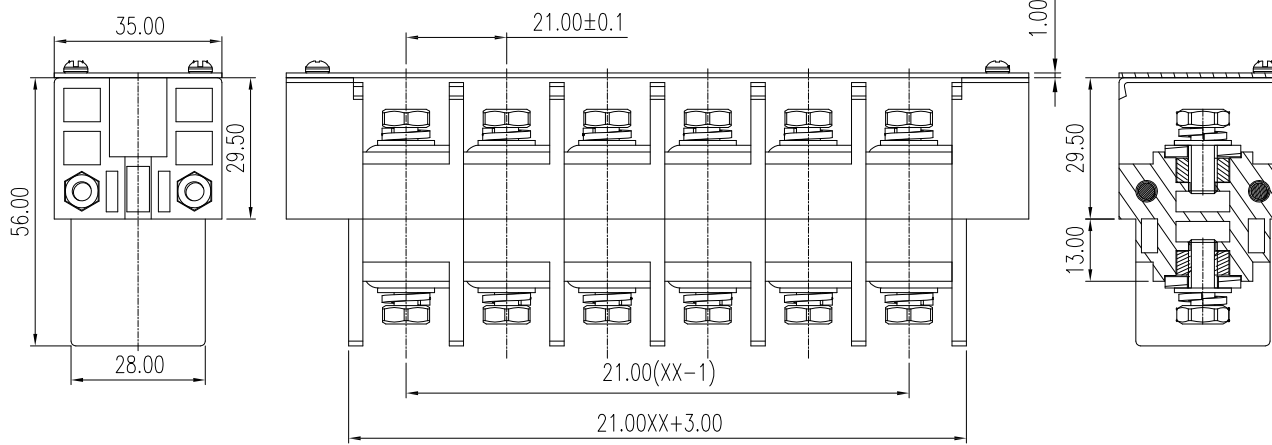
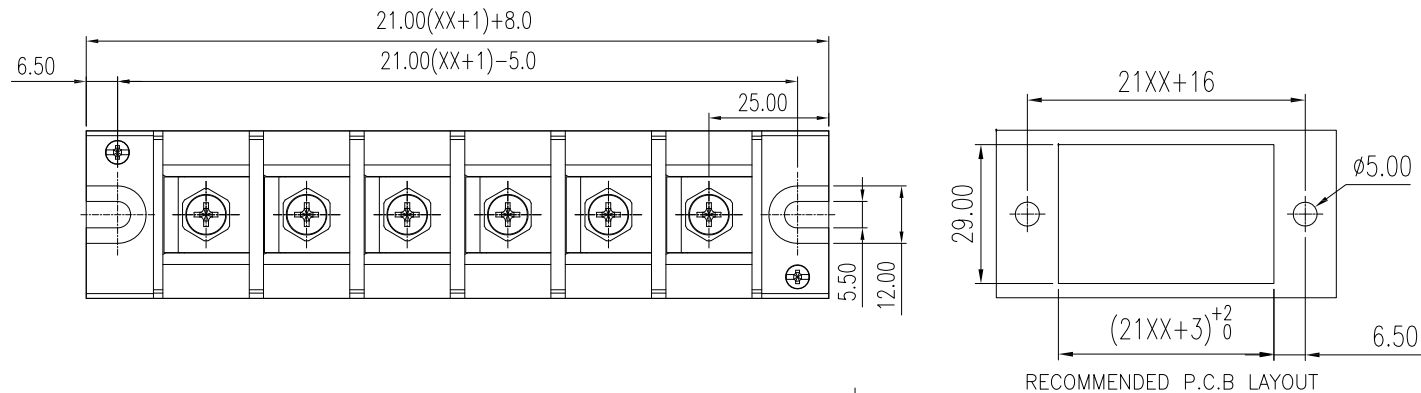

Poles: 01 thru 15

SPECIFICATIONS:

Material:
Insulator: PBT, rated UL 94V-0
Insulator color: Black
Contacts: Copper Alloy, Tin plated
Screw: M6 Steel, Zinc plated
 Electrical:
Voltage rating: 600 V
Current rating: 115 A
Contact resistance: 20 mohms
Insulation resistance: 1000 Mohms / DC500V
Dielectric withstanding voltage: 2,500 VAC for 1 minute
 Mechanical:
Wire Range: 8~2 AWG
Torque: 3.0Nm
Temperature Rating:
 -40°C to +130°C
 Environmental:
 Lead free, RoHS compliant.



	linear dimension (Tolerances Standard)											≡	-	∥	⊥		
	variable	to	over	over	over	over	over	over	over	over	over					all	to
range	to	6	10	18	30	50	80	120	160	200	250	all	to	5	30	120	to
tolerance	±0.1	±0.14	±0.19	±0.25	±0.32	±0.43	±0.57	±0.72	±0.88	±1.05	±1.25	0.5	0.025	0.06	0.12	0.4	

UNLESS OTHERWISE SPECIFIED
 ALL DIMENSIONS ARE MILLIMETERS
 TOLERANCES: EXCEPT AS NOTED

SEE CHART

ADAM TECH INTERCONNECTS
 909 Rahway Avenue,
 Union, NJ 07083
 Phone: 908-687-5000
 Fax: 908-687-5710

APPROVALS		DATE
DRAWN	AY	11/26/18
CHECKED	AC	11/26/18
APPROVED		

TITLE		TERMINAL BLOCK, .827 [21.00] PITCH W/ CLEAR COVER		
SIZE	PART NO.	REV.		
X	TBU-XX-W4-CCS	-		
REF:	S00067C	SCALE:	NTS	SHEET 1 OF 1