



MAX16820 Evaluation Kit

General Description

The MAX16820 evaluation kit (EV kit) demonstrates a step-down, constant-current, hysteretic controlled switching regulator for driving high-brightness LEDs (HB LEDs) using the MAX16820 controller IC. This EV kit is configured to supply an average output LED current of 1A, and operates from a 5V to 28V supply.

The EV kit eases evaluation of the MAX16820 dedicated pulse-width-modulation (PWM) dimming control and undervoltage lockout (UVLO) features.

The MAX16820 EV kit comes with the MAX16820 installed. The MAX16820 EV kit can also be used to evaluate the MAX16819. Contact the factory for free samples of the pin-compatible MAX16819 to evaluate this part.

Features

- ◆ Operates from a 5V to 28V, 1.5A Supply
- ◆ Constant LED Current Control
- ◆ 1A Average LED Current
- ◆ PWM Dimming Control Up to 20kHz
- ◆ Fully Assembled and Tested

Ordering Information

PART	TEMP RANGE	IC PACKAGE
MAX16820EVKIT+	0°C to +70°C*	6 TDFN-EP**

+ Denotes a lead-free and RoHS-compliant EV kit.

*This limited temperature range applies to the EV kit PCB only. The MAX16820 IC temperature range is -40°C to +125°C.

**EP = Exposed paddle.

Component List

DESIGNATION	QTY	DESCRIPTION
C1	0	Not installed, capacitor (2220)
C2	1	1 μ F \pm 10%, 50V X7R ceramic capacitor (1210) Murata GRM32RR71H105K or TDK C3225X7R1H105K
C3	0	Not installed, capacitor (1206)
C4	1	1 μ F \pm 10%, 16V X7R ceramic capacitor (0603) Murata GRM188R71C105K or TDK C1608X7R1C105K
D1	1	30V, 1A Schottky diode (SOD-123) Fairchild Semiconductor FBR130
JU1	1	2-pin header
L1	1	56 μ H, 940mA inductor (7.3mm x 8.1mm) Sumida CR75NP-560KC

DESIGNATION	QTY	DESCRIPTION
N1	1	30V, 2.7A n-channel MOSFET (SOT23) Fairchild Semiconductor FDN359BN
R1	1	0.2 Ω \pm 1%, 0.5W sense resistor (1206) IRC LRC-LR1206LF-01-R200-F
R2	1	100k Ω \pm 5% resistor (0603)
U1	1	MAX16820ATT+ (6-pin TDFN-EP, 3mm x 3mm x 0.8mm)
—	1	Shunt (JU1)
—	1	PCB: MAX16820 Evaluation Kit+

Evaluates: MAX16819/MAX16820

MAX16820 Evaluation Kit

Component Suppliers

SUPPLIER	PHONE	WEBSITE
Fairchild Semiconductor	888-522-5372	www.fairchildsemi.com
IRC	361-992-7900	www.ircctt.com
Murata Mfg. Co., Ltd.	770-436-1300	www.murata.com
Sumida Corp.	847-545-6700	www.sumida.com
TDK Corp.	847-803-6100	www.component.tdk.com

Note: Indicate that you are using the MAX16820 when contacting these component suppliers.

Quick Start

Recommended Equipment

- 24V, 1.5A DC power supply
- Voltmeter
- LED load rated for at least 1A and a total LED forward voltage drop $V_{FLED} \leq 20V$

Procedure

The MAX16820 EV kit is fully assembled and tested. Follow the steps below to verify board operation.

Caution: Do not turn on the power supply until all connections are completed.

- 1) Verify that a shunt is installed on JU1 (MAX16820 disabled).
- 2) Set the DC power-supply output to 24V.
- 3) Disable the power-supply output.
- 4) Connect the power-supply ground to the GND pad on the EV kit.
- 5) Connect the power-supply output to the VIN pad on the EV kit.
- 6) Connect the LED load's anode to the LED+ output pad and the cathode to the LED- output pad.
- 7) Enable the power supply.
- 8) Remove the shunt on JU1 (MAX16820 enabled).
- 9) Measure the voltage across the LED+ and LED- pads and verify that the voltmeter reads approximately V_{FLED} .

Detailed Description

The MAX16820 EV kit features the MAX16820 controller and demonstrates a step-down, constant-current, hysteretic controlled regulator for driving HB LEDs. The MAX16820 EV kit output is current-controlled by monitoring the voltage across external high-side sense resistor R1 in series with the LED output. In hysteretic mode, the MAX16820 EV kit is configured to output an LED current of $1A \pm 6\%$ (I_{LED}). The MAX16820 VIN rising and falling UVLO threshold points are 5V (max) and 4.5V (min), respectively. The EV kit can operate from a 5V to 28V supply capable of 1.5A.

Typically, capacitor C1 is not required if the power supply is relatively close to the EV kit. If long wires are used to connect the power supply to the EV kit, install up to 10 μ F of bulk capacitance at the surface-mount 2220 pads provided for C1.

Jumper Selection

Enable

EV kit jumper JU1 enables the MAX16820. See Table 1 for JU1 configuration.

Table 1. MAX16820 Enable (Jumper JU1)

SHUNT POSITION	DIM PIN	EV KIT FUNCTION
Installed	Connected to GND	MAX16820 disabled
Not installed	Pulled to VCC through resistor R2	MAX16820 enabled (DIM pin can be used for PWM dimming)

MAX16820 Evaluation Kit

Hysteretic Mode

To enter hysteretic mode, the following input requirements must be met: set V_{IN} above 5V or above $V_{FLED} + 4V$ (whichever is greater), and provide 1.1A of input current to the EV kit. If low-voltage or low-current input conditions fail to meet the input requirements for hysteretic mode, the MAX16820 controller operates in linear mode providing DC current to the LED load.

The MAX16820's DRV pin drives the external MOSFET (N1) hysteretically. The MAX16820 drives N1 until the LED current reaches the upper current-sense threshold. At that point, the controller disables N1 until the LED current reaches the lower current-sense threshold. The LED current will continuously ripple between $\pm 8\%$ of I_{LED} (1A). To disable the DRV output, set V_{IN} below 4.5V when V_{IN} is falling or install a shunt on jumper JU1.

Output Current Setting

In hysteretic mode, the MAX16820 EV kit circuit's average LED current (I_{LED}) is configured to 1A by sense resistor R1. See the equation below to design for a different I_{LED} and for selecting a new resistor value. If designing for a higher I_{LED} , verify that the new current setting does not exceed the power rating of components R1, L1, N1, and D1. See the *Component Selection* section for more information:

$$R1 = \frac{1}{2} \frac{(V_{SNSHI} + V_{SNSLO})}{I_{LED}}$$

where I_{LED} = desired average LED current, V_{SNSHI} (210mV) is the MAX16820's upper-sense-voltage threshold, and V_{SNSLO} (190mV) is the MAX16820's lower-sense-voltage threshold.

Component Selection

Use the MAX16820 Design Calculator, available at www.maxim-ic.com/MAX16819-20-Tool, to make proper component selections for custom designs and to determine the associated LED ripple current. Increase the value of inductor L1 to decrease ripple current. When prompted by the Design Calculator, the forward voltage of freewheel diode D1 is 0.5V.

LED Ripple Current

Typically, the LED ripple current equals the inductor ripple current. To reduce the LED ripple current, install optional output capacitor C3. The EV kit provides surface-mount 0603 pads for a capacitor nominal value of 0.1 μ F.

LED Dimming

The MAX16820 EV kit features a DIM input PCB pad that can be used for controlling LED brightness. Remove the shunt on jumper JU1 (Table 1). Connect a digital PWM signal with a 2.8V to V_{IN} logic level and a switching frequency between 100Hz and 20kHz. Frequencies lower than 100Hz can introduce flickering in the light output. Vary the duty cycle to adjust the LED brightness. LED brightness increases when the duty cycle increases and vice versa. When the PWM signal's duty cycle is 100%, the LEDs are fully on.

Evaluating the MAX16819

The MAX16820 EV kit can also evaluate the MAX16819 controller by replacing IC U1.

Contact the following number for a free sample of the MAX16819ATT+. Maxim samples: 800-998-8800.

Evaluates: MAX16819/MAX16820

MAX16820 Evaluation Kit

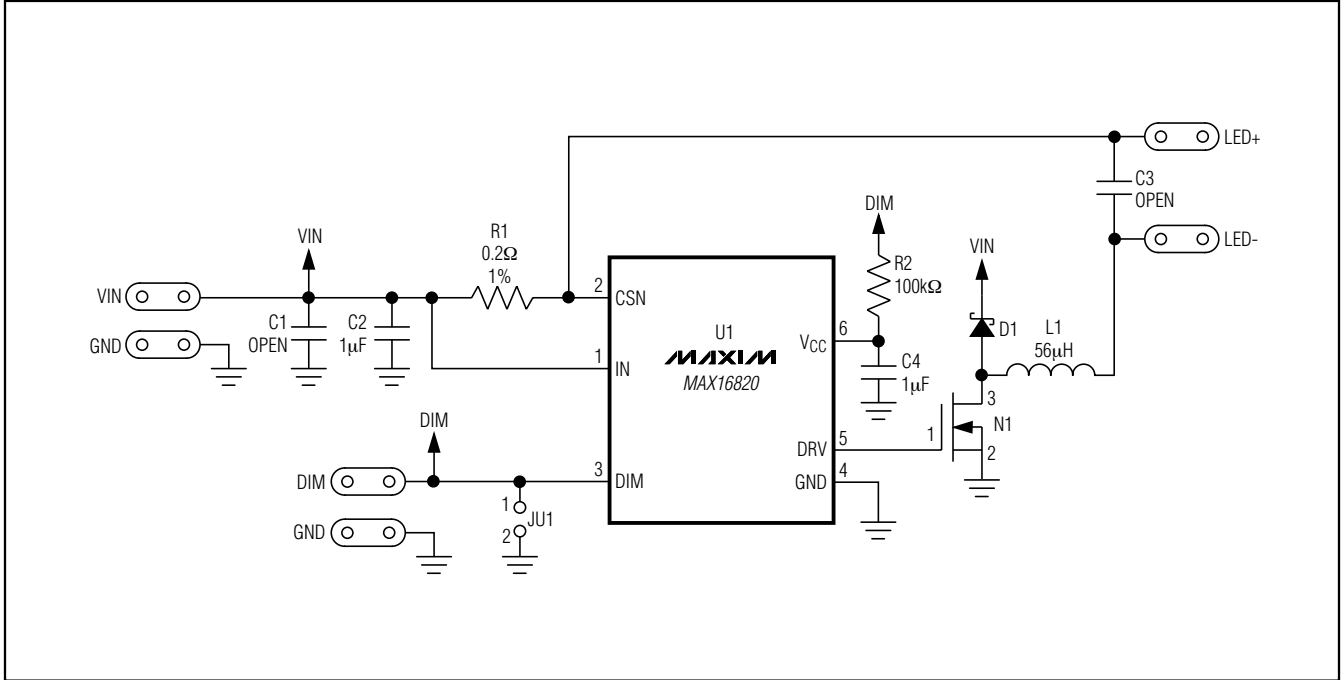

Figure 1. MAX16820 EV Kit Schematic Diagram

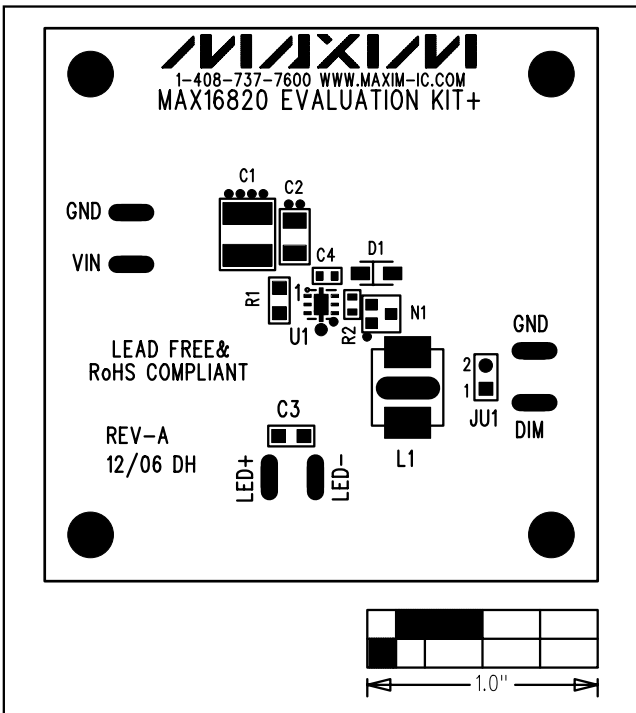

Figure 2. MAX16820 EV Kit Component Placement Guide—Component Side

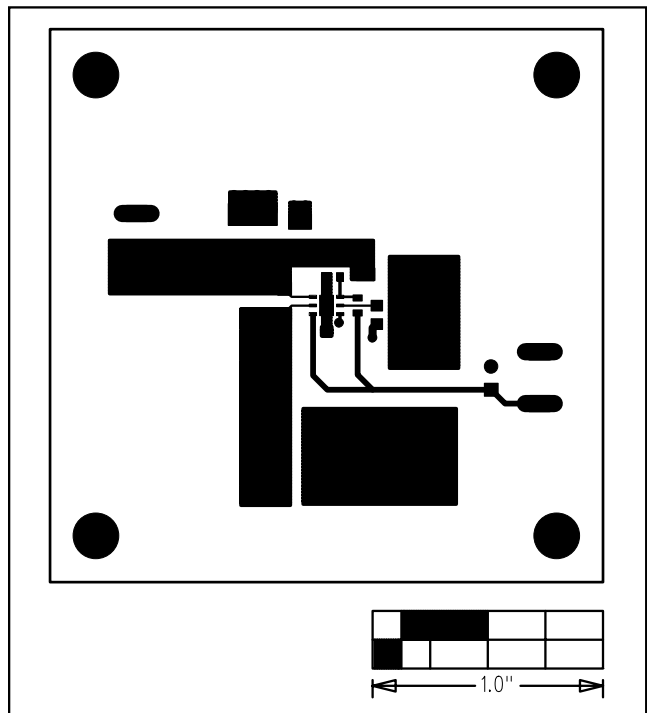

Figure 3. MAX16820 EV Kit PCB Layout—Component Side

MAX16820 Evaluation Kit

Evaluates: MAX16819/MAX16820

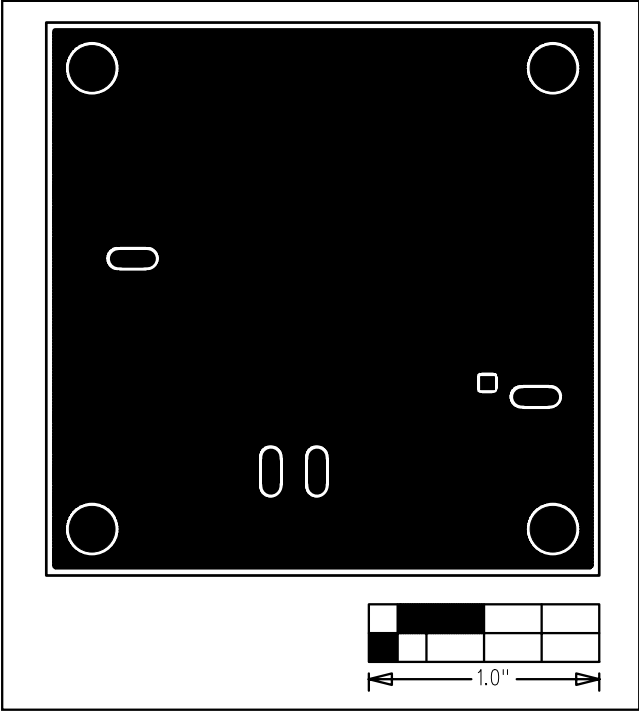

Figure 4. MAX16820 EV Kit PCB Layout—Solder Side

Maxim cannot assume responsibility for use of any circuitry other than circuitry entirely embodied in a Maxim product. No circuit patent licenses are implied. Maxim reserves the right to change the circuitry and specifications without notice at any time.

Maxim Integrated Products, 120 San Gabriel Drive, Sunnyvale, CA 94086 408-737-7600 _____ 5

© 2007 Maxim Integrated Products

MAXIM is a registered trademark of Maxim Integrated Products, Inc.

Mouser Electronics

Authorized Distributor

Click to View Pricing, Inventory, Delivery & Lifecycle Information:

[Analog Devices Inc.:](#)

[MAX16820EVKIT+](#)