

### 2W, 2512, Low Resistance Chip Resistor (Lead / Halogen Free)

#### 1. Scope

This specification applies to 6.35mm x 3.2mm size 2W.

#### 2. Features / Applications

- Welding construction; excellent long-term stability
- Ideal for all types of current sensing, voltage division and pulse applications
- Industrial applications & Current Sensor Resistor
- RoHS compliant

#### 3. Type Designation

S C M M    2512    S    2    —    □ □ □ □    □  
 (1)        (2)    (3)    (4)                    (5)    (6)

Where

(1) Series No.

(2) Size

(3) Terminal Type:

S = Short terminal type

(4) Power Rating:

2 = 2W

(5) Resistance value:

R010 = 0.01Ω, 0M30 = 0.0003Ω

(6) Tolerance

F = ±1%, G = ±2%, J = ±5%

#### 4. Dimensions and schematic

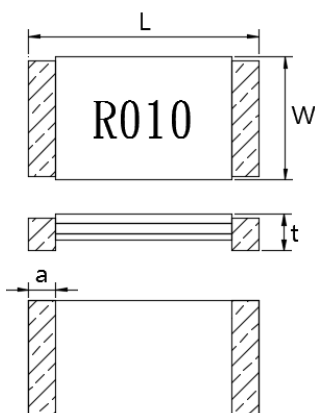

Dimensions (mm)	Resistance Range <sup>1</sup>			
	0.3, 0.5, 0.75, 0.8 mΩ	1, 2, 3, 4 mΩ	5, 6 mΩ	7, 8, 9, 10, 15, 20 mΩ
L	6.35 ± 0.25			
W	3.20 ± 0.25			
t	0.60 ± 0.25			
a	2.55 ± 0.25	2.05 ± 0.25	1.15 ± 0.25	0.70 ± 0.25

Note: 1. Other resistance value required, please contact sales

2. 0.3, 0.5, 0.75, 0.8mΩ without marking

Figure 1. Construction and Dimensions

5. Specification

Characteristics	Feature		
Power Rating*	2W		
Resistance Value	0.3 ~ 20 mΩ		
Temperature Coefficient of Resistance	0.3 mΩ	0.5, 0.75, 0.8 mΩ	1, 2, 3, 4, 5, 6, 7, 8, 9, 10, 15, 20 mΩ
	± 125 ppm/°C	± 75 ppm/°C	± 50 ppm/°C
Operation Temperature Range	-65°C ~ +170°C		
Resistance Tolerance	± 1% (F), ± 2% (G), ± 5% (J)		
Insulation Resistance	Over 100MΩ		
Maximum Working Voltage (V)	$(P \cdot R)^{1/2}$		

Note \* :

For resistors operated at ambient temperature in excess of 70°C, the maximum load shall be derated in accordance with the following curve.

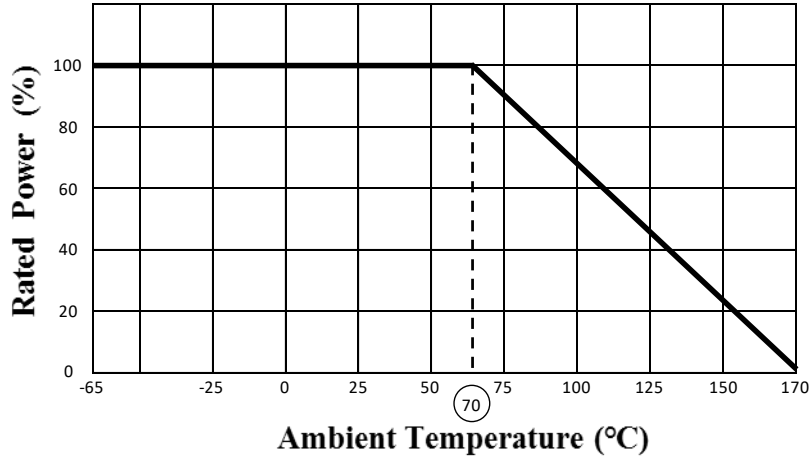

Figure 2. : Power Temperature Derating Curve

6. Characteristics

6-1 Electrical

Item	Specification and Requirement	Test Method
Temperature Coefficient (TCR)	As follow specification .	JIS-C-5201 +25°C/ +125°C
Short Time Overload	$\Delta R: \pm 0.5\%$ Without damage by flashover, spark, arcing, burning or breakdown	JIS-C-5201-1 4.13 2.5 x rated power for 5 seconds
Insulation Resistance	Over 100 M $\Omega$ on Overcoat layer face up	JIS-C-5201-1 4.6 100V <sub>DC</sub> for 60 +10/-0 seconds
Voltage Proof	$\Delta R: \pm 1\%$ Without damage by flashover, spark, arcing, burning or breakdown	JIS-C-5201-1 4.7 400V <sub>AC</sub> (rms.) for 60 +10/ -0 seconds
ESD	$\Delta R: \pm 1\%$	AEC-Q200-002 Human body, 3KV

### 6-2 Mechanical

Item	Specification and Requirement	Test Method
Solderability	The surface of terminal immersed shall be minimum of 95% covered with a new coating of solder	JIS-C-5201-1 4.17 245 ± 5°C for 5 ± 0.5 seconds
Resistance to Solder Heat	ΔR: ± 0.5% Without distinct deformation in appearance	JIS-C-5201-1 4.18 260±5°C for 10± 1 seconds
Board Flex	ΔR: ± 1.0% Without mechanical damage such as break	AEC-Q200-005 Bending value: 2 mm for 60 ± 1 seconds
Resistance to solvent	Without mechanical and distinct damage in appearance	MIL-STD-202 Method 215 Add Aqueous wash chemical - OKEM Clean or equivalent. Do not use banned solvents
Vibration	ΔR: ± 0.5% Without mechanical damage such as break	MIL-STD-202 Method 204 5g's for 20 minutes, 12 cycles each of 3 orientations. Test from 10-2000Hz
Mechanical Shock	ΔR: ± 0.5% Without mechanical damage such as break	MIL-STD-202 Method 213 100g's peak value, 6ms, Half-sine waveform, 12.3ft/sec
Terminal Strength (SMD)	ΔR: ± 1% Without mechanical damage such as break.	AEC-Q200-006 Force of 1.8Kg for 60 seconds.

### 6-3 Endurance

Item	Specification and Requirement	Test Method
Temperature Cycling	$\Delta R: \pm 0.5\%$ Without distinct damage in appearance	JESD22 Method JA-104 1000 cycles, (-55°C~150°C) 30min maximum dwell time at each temperature.
Biased Humidity	$\Delta R: \pm 0.5\%$	MIL-STD-202 Method 103 1000 hours, 85°C/85%R.H, applied for 10% rated power Measurement at 24±4 hours after test conclusion.
Operational Life	$\Delta R: \pm 1.0\%$ Without distinct damage in appearance	MIL-STD-202 Method 108 70°C, 100% rated power 1.5 hours ON, 0.5 hours Off For total 1000 hours Measurement at 24±4 hours after test conclusion.
High Temperature Storage	$\Delta R: \pm 1.0\%$ Without distinct damage in appearance	MIL-STD-202 Method 108 170°C for total 1,000 hours

### 7. Recommended Solder Pad Dimensions

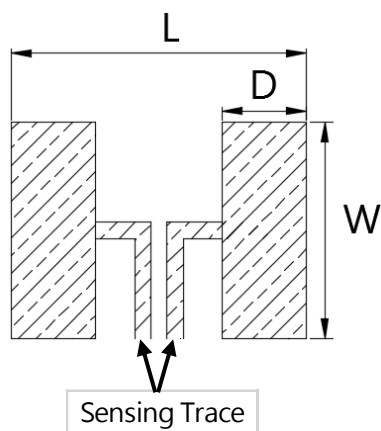

Resistance Range	Dimensions		
	W (mm)	L (mm)	D (mm)
0.3, 0.5, 0.75, 0.8, 1, 2, 3, 4 mΩ	3.7	7.35	3.20
5, 6 mΩ			2.10
7, 8, 9, 10, 15, 20 mΩ			1.65

8. Packaging

8-1 Dimensions

8-1-1 Tape packaging dimensions

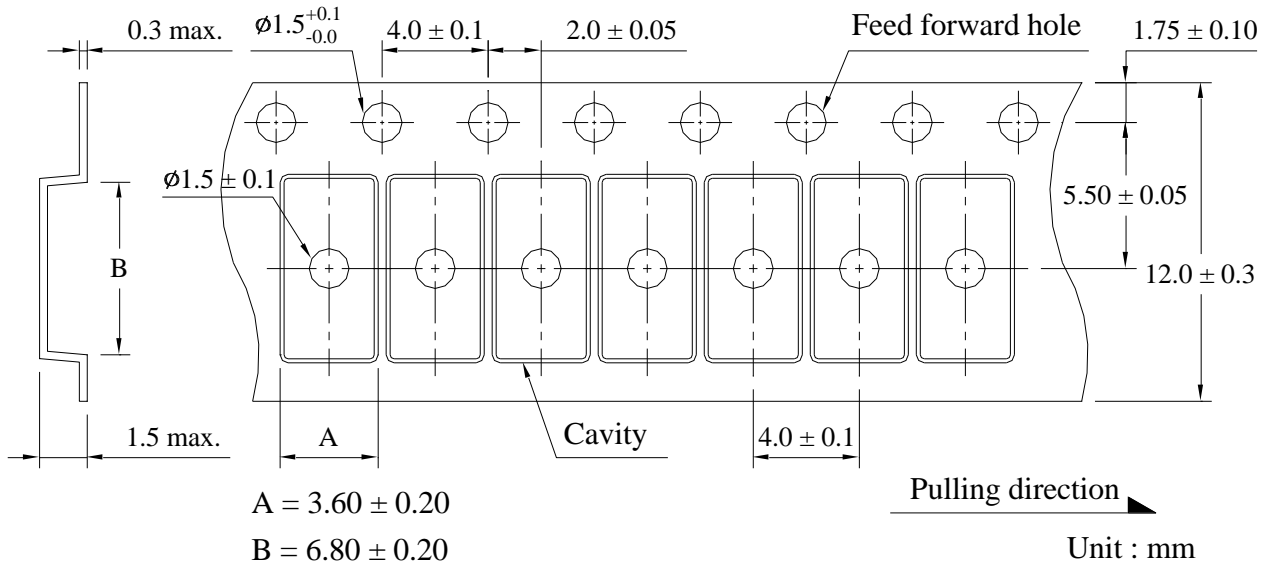

8-1-2 Reel dimensions

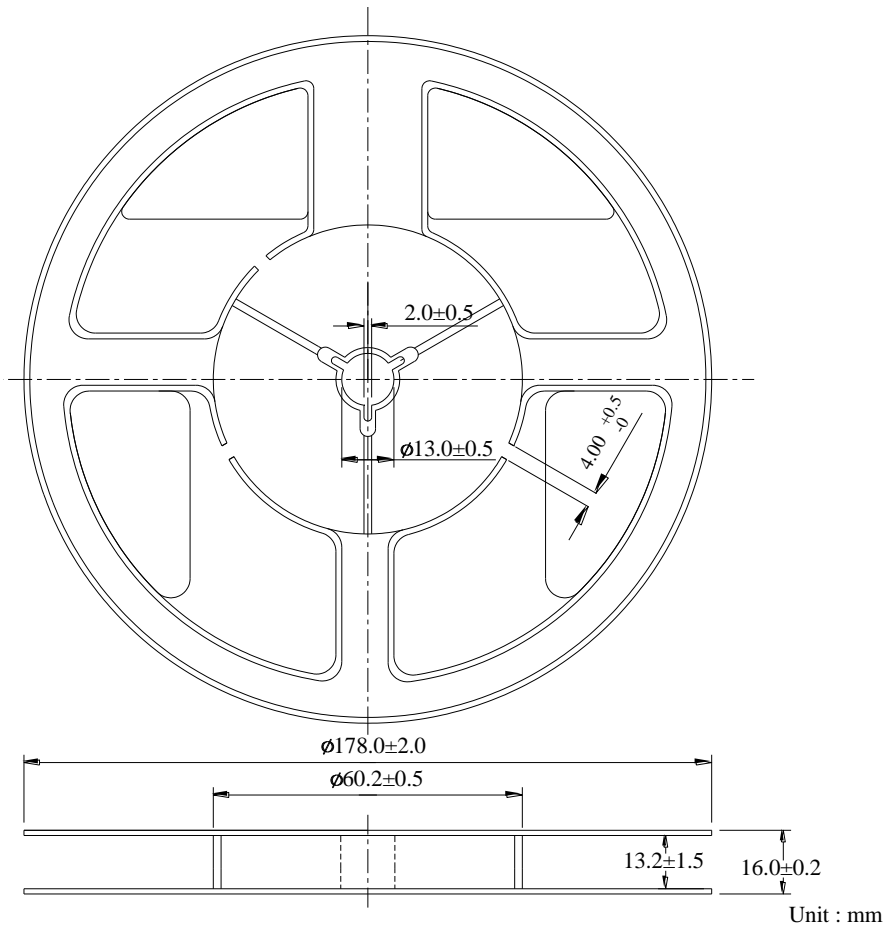

#### 8-2 Peel Strength of Top Cover Tape

The peel speed shall be about 300mm/min.

The peel force of top cover tape shall between 0.1 to 0.7N

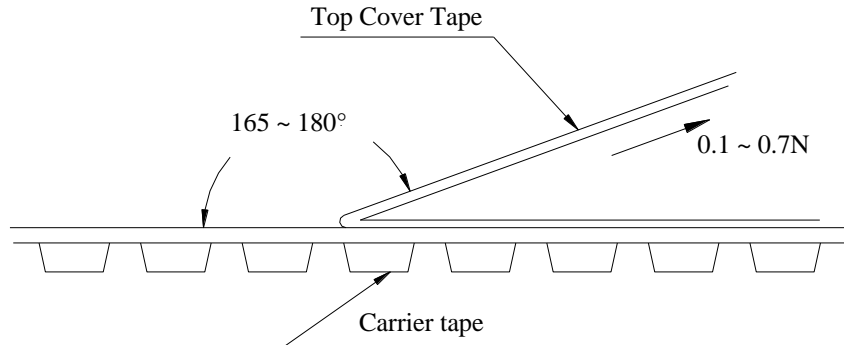

#### 8-3 Number of Taping

2,000 pieces / reel

#### 8-4 Label marking

The following items shall be marked on the reel.

- (1) Type designation
- (2) Quantity
- (3) Manufacturing date code
- (4) Manufacturer's name
- (5) The country of origin

9. Care note

9-1 Care note for storage

- (1) Chip resistor shall be stored in a room where temperature and humidity must be controlled. (temperature 5 to 35°C, humidity < 60% RH) However, a humidity keep it low, as it is possible.
- (2) Chip resistor shall be stored as direct sunshine doesn't hit on it.
- (3) Chip resistor shall be stored with no moisture, dust, a material that will make solderability inferior, and a harmful gas (Chloridation hydrogen, sulfurous acid gas, and sulfuration hydrogen)

9-2 Care note for operating and handling

- (1) It is necessary to protect the edge and protection coat of resistors from mechanical stress.
- (2) Handle with care when printing circuit board (PCB) is divided or fixed on support body, because bending of printing circuit board (PCB) mounting will make mechanical stress for resistors.
- (3) Resistors shall be used with in rated range shown in specification. Especially, if voltage more than specified value will be loaded to resistor, there is a case it will make damage for machine because of temperature rise depending on generating of heat, and increase resistance value or breaks.
- (4) In case that resistor is loaded a rated voltage, it is necessary to confirms temperature of a resistor and to reduce a load power according to load reduction curve, because a temperature rise of a resistor depends on influence of heat from mounting density and neighboring element.
- (5) Observe Limiting element voltage and maximum overload voltage specified in each specification
- (6) If there is possibility that a large voltage (pulse voltage, shock voltage) charge to resistor, it is necessary that operating condition shall be set up before use.