

## LNB supply and control IC with step-up and I<sup>2</sup>C interface

Datasheet - production data

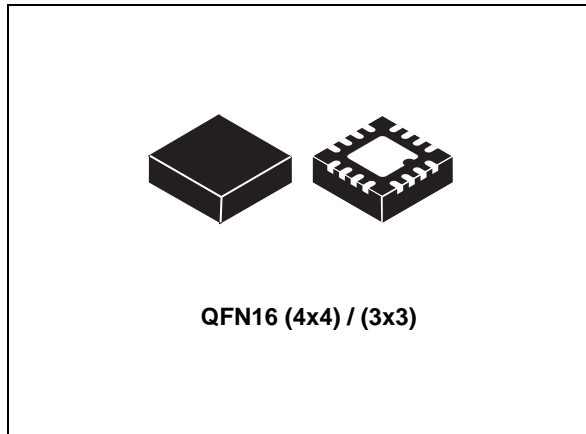

- Low-drop post regulator and high efficiency step-up PWM with integrated power N-MOS allowing low power losses
- Overload and overtemperature internal protection with I<sup>2</sup>C diagnostic bits
- LNB short-circuit dynamic protection
- +/- 4 kV ESD tolerant on output power pins

### Applications

- STB satellite receivers
- TV satellite receivers
- PC card satellite receivers

### Features

- Complete interface between LNB and I<sup>2</sup>C bus
- Built-in DC-DC converter for single 12 V supply operation and high efficiency (typ. 93% @ 0.5 A)
- Selectable output current limit by external resistor
- Compliant with main satellite receiver output voltage specifications
- Accurate built-in 22 kHz tone generator suits widely accepted standards
- EXTM pin, auxiliary 22 kHz modulation input (LNBH29E) extends design flexibility
- 22 kHz tone waveform integrity guaranteed also at no load condition

### Description

Intended for analog and digital satellite receivers/Sat-TV and Sat-PC cards, the LNBH29 series is a monolithic voltage regulator and interface IC, assembled in QFN16 (3x3) and QFN16 (4x4) specifically designed to provide the 13 / 18 V power supply and the 22 kHz tone signaling to the LNB down-converter in the antenna dish or to the multi-switch box. In this application field, it offers a complete solution with extremely low component count, low power dissipation together with a simple design and I<sup>2</sup>C standard interfacing.

**Table 1. Device summary**

Order codes	Packages	Packaging
LNBH29PTR	QFN16 (3x3)	Tape and reel
LNBH29EPTR	QFN16 (3x3)	Tape and reel
LNBH29QTR	QFN16 (4x4)	Tape and reel
LNBH29EQTR	QFN16 (4x4)	Tape and reel

# Contents

<b>1</b>	<b>Block diagram</b>	<b>3</b>
<b>2</b>	<b>Application information</b>	<b>4</b>
2.1	DiSEqC™ data encoding	4
2.2	LNBH29: data encoding by external DiSEqC envelope control through the DSQIN pin	4
2.3	LNBH29E: DISEQC data encoding by external 22 kHz signal connected to the EXTM pin	5
2.4	Output current limit selection	5
2.5	Output voltage selection	5
2.6	Diagnostic and protection functions	5
2.7	Surge protection and TVS diodes	6
2.8	VMON: output voltage diagnostic	6
2.9	PDO: overcurrent detection on output pull-down stage	6
2.10	Power-on I <sup>2</sup> C interface reset and undervoltage lockout	6
2.11	PNG: input voltage minimum detection	7
2.12	COMP: boost capacitors and inductor	7
2.13	OLF: overcurrent and short-circuit protection and diagnostic	7
2.14	OTF: thermal protection and diagnostic	7
<b>3</b>	<b>Pin configuration</b>	<b>8</b>
<b>4</b>	<b>Maximum ratings</b>	<b>10</b>
<b>5</b>	<b>Typical application circuits</b>	<b>11</b>
<b>6</b>	<b>I<sup>2</sup>C bus interface</b>	<b>13</b>
6.1	Data validity	13
6.2	Start and stop condition	13
6.3	Byte format	13
6.4	Acknowledge	13
6.5	Transmission without acknowledge	13

---

<b>7</b>	<b>I<sup>2</sup>C interface protocol</b> .....	<b>15</b>
7.1	Write mode transmission .....	15
7.2	Read mode transmission .....	15
7.3	DATA register .....	16
7.4	STATUS register .....	17
<b>8</b>	<b>Electrical characteristics</b> .....	<b>19</b>
<b>9</b>	<b>Package mechanical data</b> .....	<b>22</b>
<b>10</b>	<b>Revision history</b> .....	<b>30</b>

# 1 Block diagram

Figure 1. Block diagram

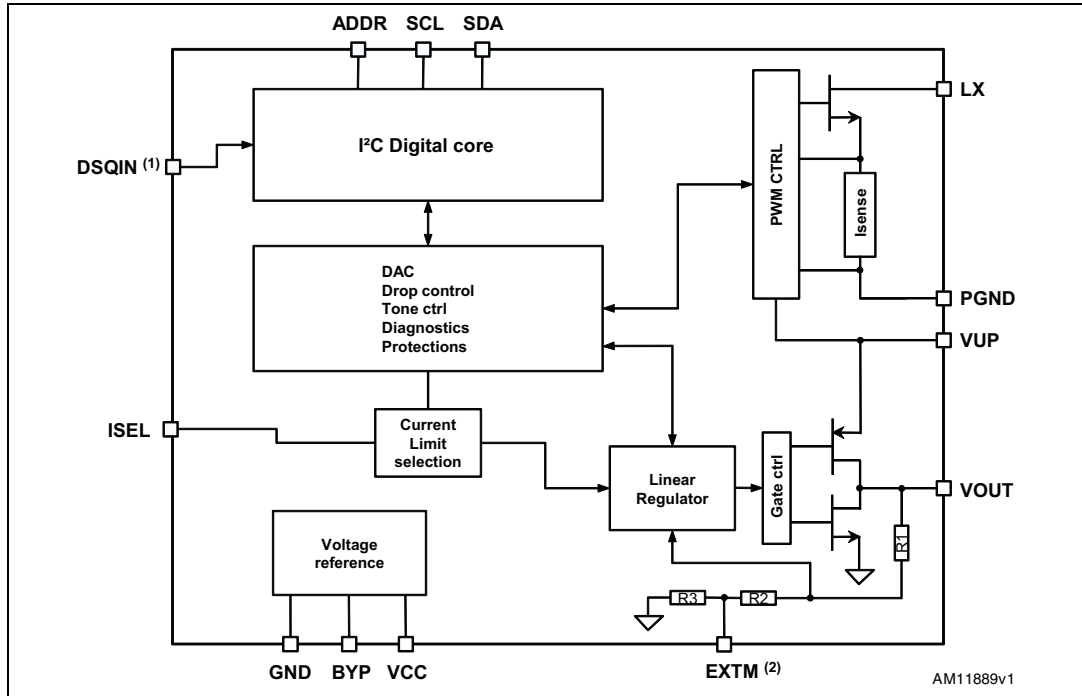

- 1. DSQIN pin available only on the LNBH29.
- 2. EXT M pin available only on the LNBH29E.

## 2 Application information

This IC has a built-in DC-DC step-up converter that, from a single source from 9 V to 17.5 V, generates the voltages ( $V_{UP}$ ) that allow the linear post-regulator to work with a minimum dissipated power of 0.5 W typ. @ 500 mA load (the linear post-regulator drop voltage is internally kept at  $V_{UP} - V_{OUT} = 1$  V typ.). The IC is also provided with an undervoltage lockout circuit that disables the whole circuit when the supplied  $V_{CC}$  drops below a fixed threshold (4.7 V typically). The step-up converter is provided with a soft-start function which reduces the inrush current during startup. The SS time is internally fixed at 4 ms typ. to switch from 0 to 13 V and 6 ms typ. to switch from 0 to 18 V.

### 2.1 DiSEqC™ data encoding

The LNBH29 series includes two versions with different DiSEqC control pin solutions: LNBH29 with DSQIN pin and LNBH29E with EXTM pin.

The LNBH29 is provided with the DSQIN logic input pin (TTL compatible) to be controlled by an external DiSEqC data envelope source which activates the internal 22 kHz tone generator factory trimmed. This guarantees the tone output waveform in accordance with the DiSEqC standards.

The LNBH29E is provided with the EXTM analogic modulation input pin to be connected to an external 22 kHz DiSEqC tone source. The tone output waveform depends on the characteristics of an external signal injected by means of the EXTM pin.

### 2.2 LNBH29: data encoding by external DiSEqC envelope control through the DSQIN pin

If an external DiSEqC code envelope source is available, it is possible to use the internal 22 kHz generator activated during the tone transmission by connecting the DiSEqC envelope source to the DSQIN pin (see [Section 5: Typical application circuits](#)). In this way, the internal 22 kHz signal is superimposed to the  $V_{OUT}$  DC voltage to generate the LNB output 22 kHz tone. During the period in which the DSQIN is kept HIGH, the internal control circuit activates the 22 kHz tone output.

The 22 kHz tone on the  $V_{OUT}$  pin is activated with about 6  $\mu$ s delay from the DSQIN TTL signal rising edge, and it stops with a delay time in the range of 15  $\mu$ s to 60  $\mu$ s after the 22 kHz TTL signal on DSQIN has expired (refer to [Figure 2](#)).

**Figure 2. Tone enable and disable timing (using envelope signal)**

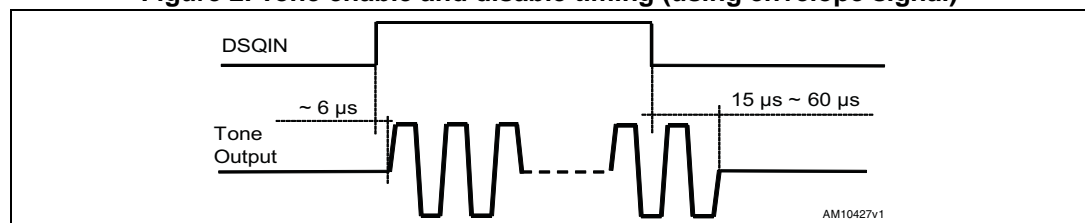

## 2.3 LNBH29E: DISEQC data encoding by external 22 kHz signal connected to the EXTM pin

In order to improve design flexibility, an analogic modulation input pin is available (EXTM) to generate the 22 kHz tone superimposed to the  $V_{OUT}$  DC output voltage. An appropriate DC blocking capacitor must be used to couple the 22 kHz modulating signal source to the EXTM pin. The EXTM pin modulates the  $V_{OUT}$  voltage through the series decoupling capacitor, so that:

$$V_{OUT(AC)} = V_{EXTM(AC)} \times G_{EXTM}$$

where  $V_{OUT(AC)}$  and  $V_{EXTM(AC)}$  are, respectively, the peak-to-peak AC voltage on the  $V_{OUT}$  pin and on the EXTM pin, while  $G_{EXTM}$  is the voltage gain between the EXTM voltage and  $V_{OUT}$  signal.

## 2.4 Output current limit selection

The linear regulator current limit threshold can be set by an external resistor connected to the ISEL pin. The resistor value defines the output current limit by the equation:

### Equation 1

$$I_{MAX}(typ.) = \frac{13915}{R_{SEL}^{1.111}}$$

where  $R_{SEL}$  is the resistor connected between ISEL and GND expressed in  $k\Omega$  and  $I_{MAX}(typ.)$  is the typical current limit threshold expressed in mA.  $I_{MAX}$  can be set up to 550 mA.

## 2.5 Output voltage selection

The linear regulator output voltage level can be easily programmed in order to accomplish application specific requirements, using 3 bits of the internal DATA register (see [Section 7.1: Write mode transmission](#) and [Table 7](#) for exact programmable values). Register writing is accessible via the I<sup>2</sup>C bus.

## 2.6 Diagnostic and protection functions

The LNBH29 series has 5 diagnostic internal functions provided via the I<sup>2</sup>C bus, by reading 5 bits on the STATUS register (in Read mode). All the diagnostic bits are, in normal operation, set to LOW. Two diagnostic bits are dedicated to the overtemperature and overload protection status (OTF and OLF) while the remaining 3 bits are dedicated to the output voltage level (VMON), to external voltage source presence on the  $V_{OUT}$  pin (PDO) and to the input voltage power not good function (PNG). Once the OLF (or OTF or PNG) bit has been activated (set to "1"), it is latched to "1" until the relevant cause is removed and a new register reading operation is done (see [Table 8](#)).

## 2.7 Surge protection and TVS diodes

The LNBH29 series is directly connected to the antenna cable in a set-top box. Atmospheric phenomenon can cause high voltage discharges on the antenna cable causing damage to the attached devices. Surge pulses occur due to direct or indirect lightning strikes to an external (outdoor) circuit. This leads to currents or electromagnetic fields causing high voltage or current transients. Transient voltage suppressor (TVS) devices are usually placed, as shown in [Figure 3](#), to protect the STB output circuits where the LNBH29 and other devices are electrically connected to the antenna cable.

Figure 3. Surge protection circuit

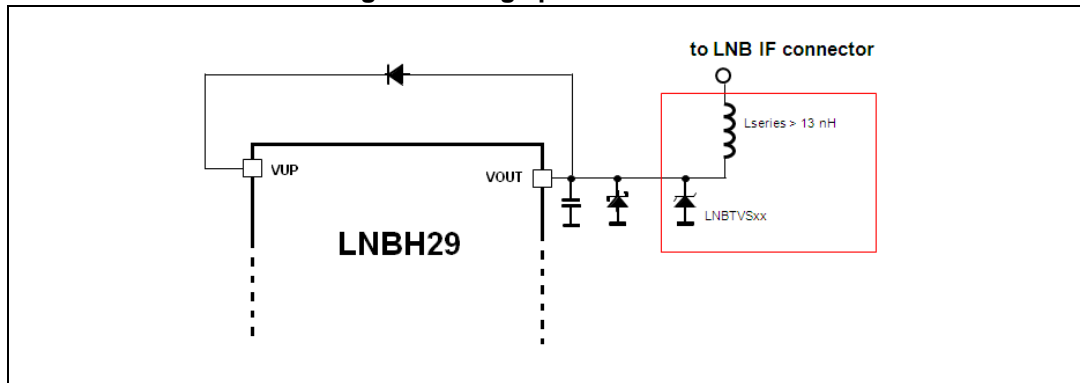

For this purpose the use of LNBTVSxx surge protection diodes specifically designed by ST is recommended. The selection of the LNBTVS diode should be made based on the maximum peak power dissipation that the diode is capable of supporting (see the LNBTVS datasheet for further details).

## 2.8 VMON: output voltage diagnostic

When device output voltage is activated ( $V_{OUT}$  pin), its value is internally monitored and, as long as the output voltage level is below the guaranteed limits, the VMON I<sup>2</sup>C bit is set to "1". See [Table 12](#) for more details.

## 2.9 PDO: overcurrent detection on output pull-down stage

When an overcurrent occurs on the pull-down output stage due to an external voltage source greater than the LNBH29 nominal  $V_{OUT}$  and for a time longer than  $I_{SINK\_TIME-OUT}$  (10 ms typ.), the PDO I<sup>2</sup>C bit is set to "1". This may happen due to an external voltage source presence on the LNB output ( $V_{OUT}$  pin).

For current threshold and de-glitch time details, see [Table 9](#).

## 2.10 Power-on I<sup>2</sup>C interface reset and undervoltage lockout

The I<sup>2</sup>C interface built into the LNBH29 series is automatically reset at power-on. As long as the  $V_{CC}$  stays below the undervoltage lockout (UVLO) threshold (4.7 V typ.), the interface does not respond to any I<sup>2</sup>C command and all DATA register bits are initialized to zeroes, therefore keeping the power blocks disabled. Once the  $V_{CC}$  rises above 4.8 V typ. the I<sup>2</sup>C interface becomes operative and the DATA registers can be configured by the main microprocessor.

## 2.11 PNG: input voltage minimum detection

When input voltage ( $V_{CC}$  pin) is lower than LPD (low power diagnostic) minimum thresholds, the PNG I<sup>2</sup>C bit is set to “1”. Refer to [Table 9](#) for threshold details.

## 2.12 COMP: boost capacitors and inductor

The DC-DC converter compensation loop can be optimized in order to properly work with both ceramic and electrolytic capacitors ( $V_{UP}$  pin). For this purpose, one I<sup>2</sup>C bit in the DATA register (COMP) can be set to “1” or “0” as follows:

COMP=0 for electrolytic capacitors

COMP=1 for ceramic capacitors

For recommended DC-DC capacitor and inductor values refer to [Section 5: Typical application circuits](#) and to the BOM in [Table 5](#).

## 2.13 OLF: overcurrent and short-circuit protection and diagnostic

In order to reduce the total power dissipation during an overload or a short-circuit condition, the device is provided with a dynamic short-circuit protection. The overcurrent protection circuit works dynamically: as soon as an overload is detected, the output current is provided only for  $T_{ON}$  time (90 ms typ.) and after that, the output is set in shutdown for a  $T_{OFF}$  time of typically 900 ms. Simultaneously, the diagnostic OLF I<sup>2</sup>C bit of the STATUS register is set to “1”. After this time has elapsed, the output is resumed for a time  $T_{ON}$ . At the end of  $T_{ON}$ , if the overload is still detected, the protection circuit cycles again through  $T_{OFF}$  and  $T_{ON}$ . At the end of a full  $T_{ON}$  in which no overload is detected, normal operation is resumed and the OLF diagnostic bit is reset to LOW after a register reading is done. Typical  $T_{ON} + T_{OFF}$  time is 990 ms, determined by an internal timer. This dynamic operation can greatly reduce the power dissipation in short-circuit conditions, while ensuring excellent power-on startup in most conditions.

## 2.14 OTF: thermal protection and diagnostic

The LNBH29 series is also protected against overheating: when the junction temperature exceeds 150 °C (typ.), the step-up converter and the linear regulator are shut off and the diagnostic OTF bit in the STATUS register is set to “1”. As soon as the overtemperature condition is removed, normal operation is automatically re-enabled, while the OTF bit is reset to “0” after a register reading operation.



### 3 Pin configuration

Figure 4. Pin connections QFN16 (3x3) and (4x4) (top view)

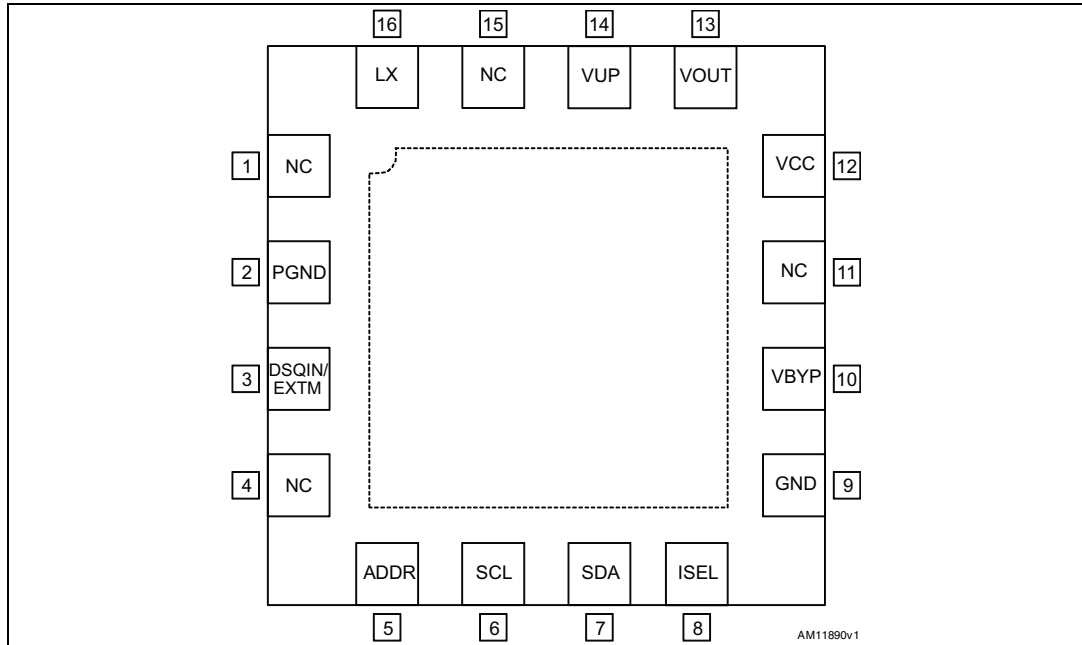

Table 2. Pin description

Pin n°	Symbol	Name	Pin function
16	LX	N-Mos drain	Integrated N-channel Power MOSFET drain.
2	P-GND	Power ground	DC-DC converter power ground. To be connected directly to the Epad.
5	ADDR	Address setting	Two I <sup>2</sup> C bus addresses available by setting the address pin level voltage. See <a href="#">Table 11</a> .
6	SCL	Serial clock	Clock from I <sup>2</sup> C bus.
7	SDA	Serial data	Bi-directional data from/to I <sup>2</sup> C bus.
8	ISEL	Current selection	The resistor “RSEL” connected between ISEL and GND defines the linear regulator current limit threshold. Refer to <a href="#">Section 2.4</a> .
9	GND	Analog ground	Analog circuits ground. To be connected directly to the Epad.
10	BYP	Bypass capacitor	Needed for internal pre-regulator filtering. The BYP pin is intended only to connect an external ceramic capacitor. Any connection of this pin to external current or voltage sources may cause permanent damage to the device.
12	V <sub>CC</sub>	Supply input	8 to 17.5 V IC DC-DC power supply.
13	V <sub>OUT</sub>	LNB output port	Output of the integrated very low drop linear regulator. See <a href="#">Table 7</a> for voltage selection and description.
14	V <sub>UP</sub>	Step-up voltage	Input of the linear post-regulator. The voltage on this pin is monitored by the internal step-up controller to keep a minimum dropout across the linear pass transistor.

Table 2. Pin description (continued)

Pin n°	Symbol	Name	Pin function
3	DSQIN (LNBH29)	DiSEqC tone envelope input	Available for LNBH29 version: this pin accepts DiSEqC envelope codes (TTL compatible) from the main DiSEqC microcontroller. The LNBH29 uses this code to enable the internally generated 22 kHz carrier superimposed to the V <sub>OUT</sub> pin DC voltage. See <a href="#">Figure 5</a> .
3	EXTM (LNBH29E)	External 22 kHz tone input	Available for LNBH29E version: the “external tone modulation” input acts on the integrated linear regulator loop to superimpose an external 22 kHz signal to the V <sub>OUT</sub> pin DC voltage. Needs DC decoupling to the AC source. See <a href="#">Figure 6</a> .
Epad	Epad	Exposed pad	To be connected with power grounds and to the ground layer through vias to dissipate the heat.
1, 4, 11, 15	N.C.	Not internally connected	Not internally connected pins. These pins can be connected to GND to improve thermal performance.

## 4 Maximum ratings

**Table 3. Absolute maximum ratings**

Symbol	Parameter	Value	Unit
$V_{CC}$	DC power supply input voltage pins	-0.3 to 20	V
$V_{UP}$	DC input voltage	-0.3 to 40	V
$I_{OUT}$	Output current	Internally limited	mA
$V_{OUT}$	DC output pin voltage	-0.3 to 40	V
$V_I$	Logic input pins voltage (SDA, SCL, DSQIN, ADDR pins)	-0.3 to 7	V
$V_{EXTM}$	EXTM pin voltage	-0.3 to 2	V
LX	LX input voltage	-0.3 to 30	V
$V_{BYP}$	Internal reference pin voltage	-0.3 to 4.6	V
ISEL	Current selection pin voltage	-0.3 to 3.5	V
$T_{STG}$	Storage temperature range	-50 to 150	°C
$T_J$	Operating junction temperature range	-25 to 125	°C
ESD	ESD rating with human body model (HBM) all pins, unless power output pins	2	kV
	ESD rating with human body model (HBM) for power output pins	4	

*Note:* Absolute maximum ratings are those values beyond which damage to the device may occur. These are stress ratings only and functional operation of the device at these conditions is not implied. Exposure to absolute-maximum-rated conditions for extended periods may affect device reliability. All voltage values are with respect to the network ground terminal.

**Table 4. Thermal data**

Symbol	Parameter	QFN (3x3)	QFN (4x4)	Unit
$R_{thJC}$	Thermal resistance junction-case	2	2	°C/W
$R_{thJA}$	Thermal resistance junction-ambient with device soldered on 2s2p 4-layer PCB provided with thermal vias below exposed pad	55	40	°C/W

# 5 Typical application circuits

Figure 5. LNBH29: DiSEqC tone envelope pin control

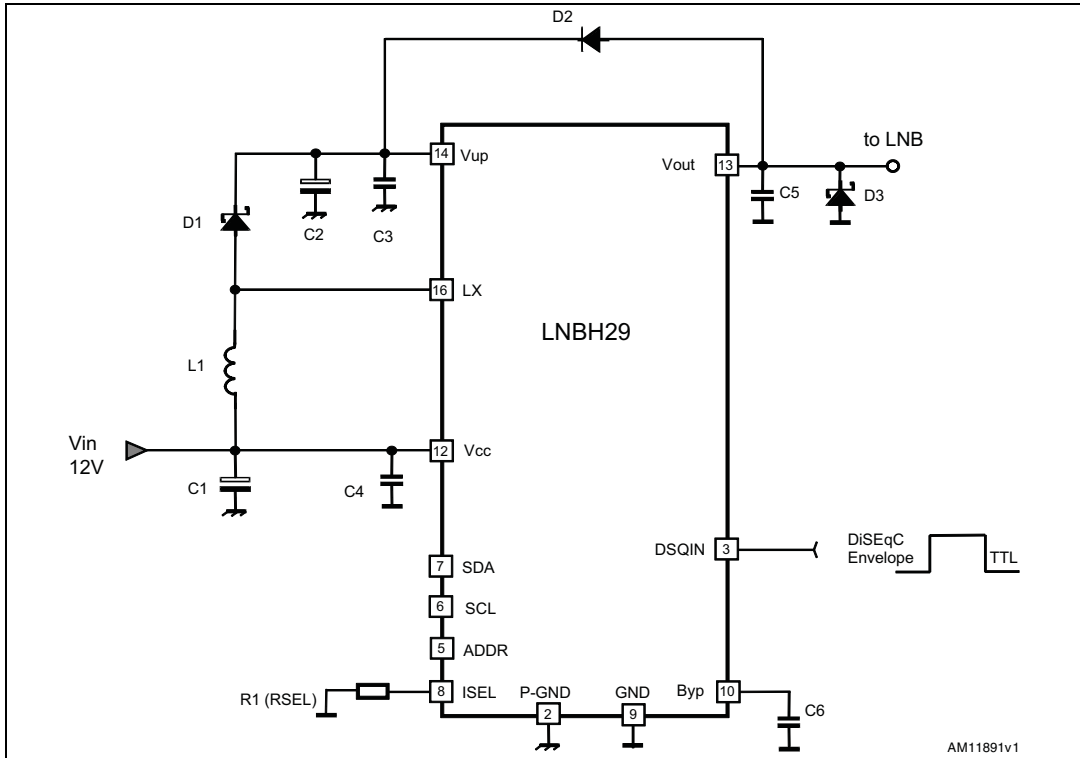

Figure 6. LNBH29E: external 22 kHz DiSEqC pin control

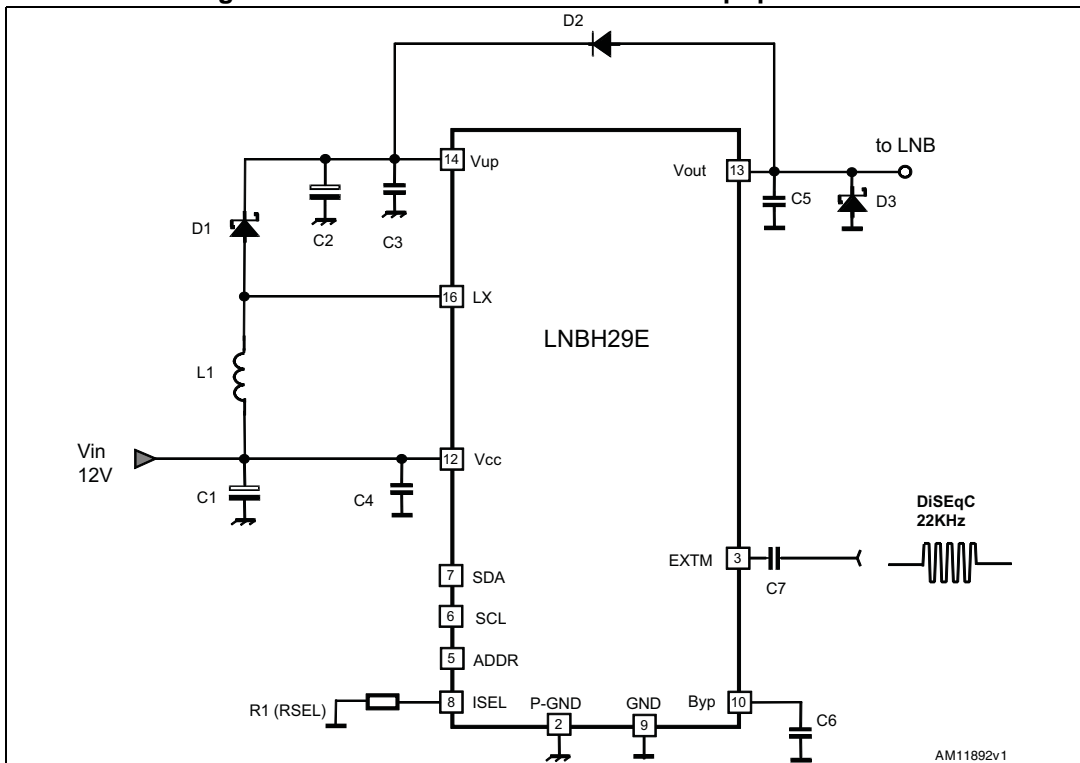

Table 5. Typical application circuit bill of material

Component	Notes
R1 (RSEL)	SMD resistor. Refer to $I_{MAX}$ current limit selection resistor values ( <a href="#">Table 9</a> ).
C1	> 25 V electrolytic capacitor, 100 $\mu$ F or higher is suitable. or > 25 V ceramic capacitor, 10 $\mu$ F or higher is suitable.
C2	With COMP=0, > 25 V electrolytic capacitor, 100 $\mu$ F or higher is suitable. or With COMP=1, > 35 V ceramic capacitor, 22 $\mu$ F (or 2 x 10 $\mu$ F) or higher is suitable.
C3	From 470 nF to 2.2 $\mu$ F ceramic capacitor. Higher values allow lower DC-DC noise.
C5	From 100 nF to 220 nF ceramic capacitor. Higher values allow lower DC-DC noise.
C4, C6	220 nF ceramic capacitors.
C7	100 nF or higher is suitable.
D1	STPS130A or similar Schottky diode.
D3	BAT54, BAT43, 1N5818, or any low power Schottky diode with $I_F(AV) > 0.2$ A, $V_{RRM} > 25$ V, $V_F < 0.5$ V. To be placed as close as possible to $V_{OUT}$ pin.
D2	1N4001-07, S1A-S1M, or any similar general purpose rectifier.
L1	With COMP=0, use 10 $\mu$ H inductor with $I_{sat} > I_{peak}$ where $I_{peak}$ is the boost converter peak current. or With COMP=1 and C2 = 22 $\mu$ F, use 6.8 $\mu$ H inductor with $I_{sat} > I_{peak}$ where $I_{peak}$ is the boost converter peak current.

## 6 I<sup>2</sup>C bus interface

Data transmission from the main microprocessor to the LNBH29 and vice versa takes place through the 2-wire I<sup>2</sup>C bus interface, consisting of the 2 lines SDA and SCL (pull-up resistors to positive supply voltage must be externally connected).

### 6.1 Data validity

As shown in [Figure 7](#), the data on the SDA line must be stable during the high semi-period of the clock. The HIGH and LOW state of the data line can only change when the clock signal on the SCL line is LOW.

### 6.2 Start and stop condition

As shown in [Figure 8](#), a start condition is a HIGH to LOW transition of the SDA line while SCL is HIGH. The stop condition is a LOW to HIGH transition of the SDA line while SCL is HIGH. A stop condition must be sent before each start condition.

### 6.3 Byte format

Every byte transferred to the SDA line must contain 8 bits. Each byte must be followed by an acknowledge bit. The MSB is transferred first.

### 6.4 Acknowledge

The master (microprocessor) puts a resistive HIGH level on the SDA line during the acknowledge clock pulse (see [Figure 9](#)). The peripheral (LNBH29) that acknowledges must pull down (LOW) the SDA line during the acknowledge clock pulse, so that the SDA line is stable LOW during this clock pulse. The peripheral which has been addressed must generate an acknowledge after the reception of each byte, otherwise the SDA line remains at the HIGH level during the ninth clock pulse time. In this case the master transmitter can generate the STOP information in order to abort the transfer. The LNBH29 does not generate an acknowledge if the  $V_{CC}$  supply is below the undervoltage lockout threshold (4.7 V typ.).

### 6.5 Transmission without acknowledge

If the detection of an acknowledge from the LNBH29 is not required, the microprocessor can use a simpler transmission: it simply waits one clock cycle without checking the slave acknowledging, and sends the new data. This approach is of course less protected from misworking and decreases the noise immunity.

Figure 7. Data validity on the I<sup>2</sup>C bus

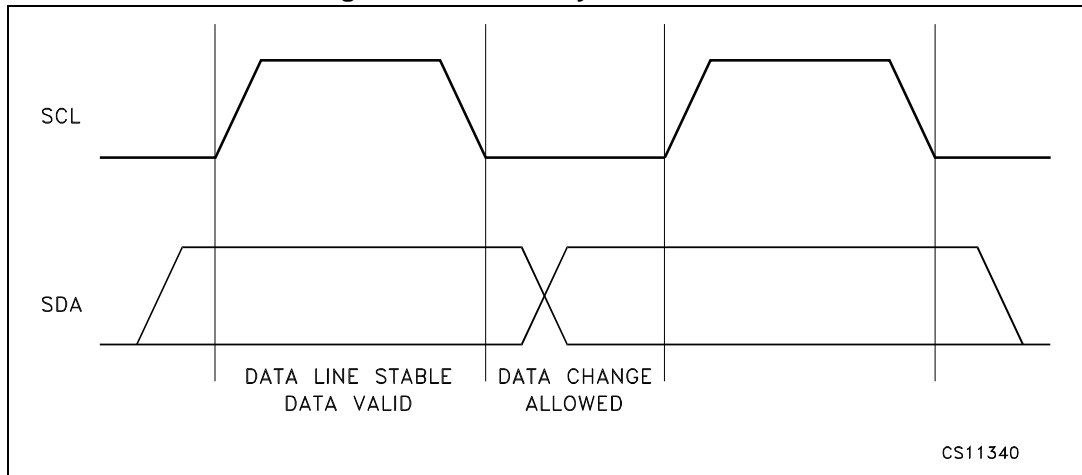

Figure 8. Timing diagram of I<sup>2</sup>C bus

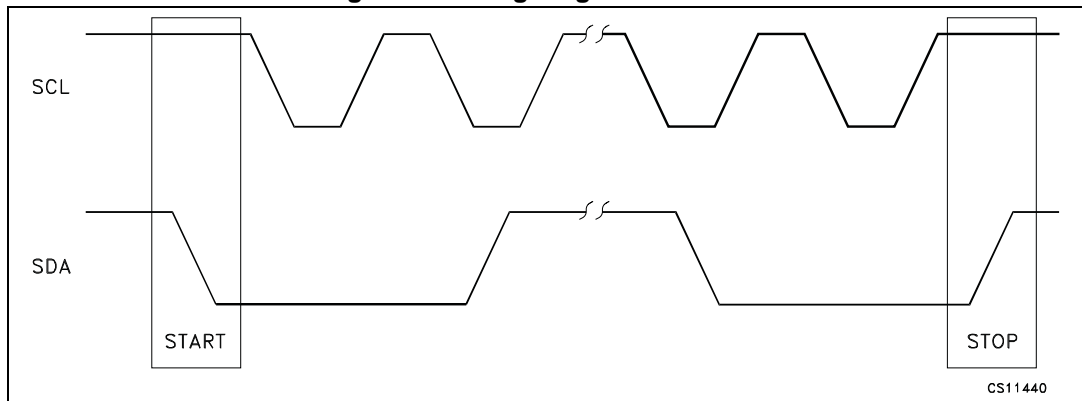
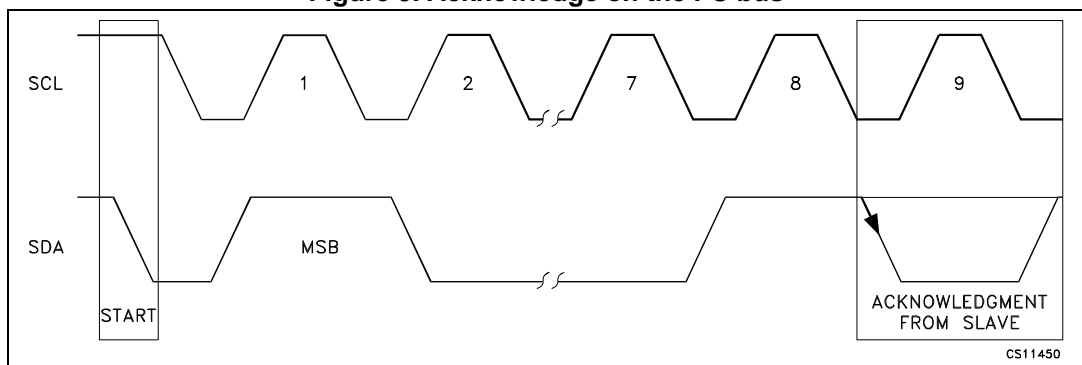

Figure 9. Acknowledge on the I<sup>2</sup>C bus



## 7 I<sup>2</sup>C interface protocol

### 7.1 Write mode transmission

The LNBH29 series interface protocol comprises:

- a start condition (S)
- a chip address byte with the LSB bit R/W = 0
- a register address (internal address of the first register to be accessed)
- a sequence of data (byte to write in the addressed internal register + acknowledge)
- a stop condition (P). The transfer lasts until a stop bit is encountered
- the LNBH29, as slave, acknowledges every byte transfer.

**Figure 10. Example of writing procedure starting with first data address 0x2**

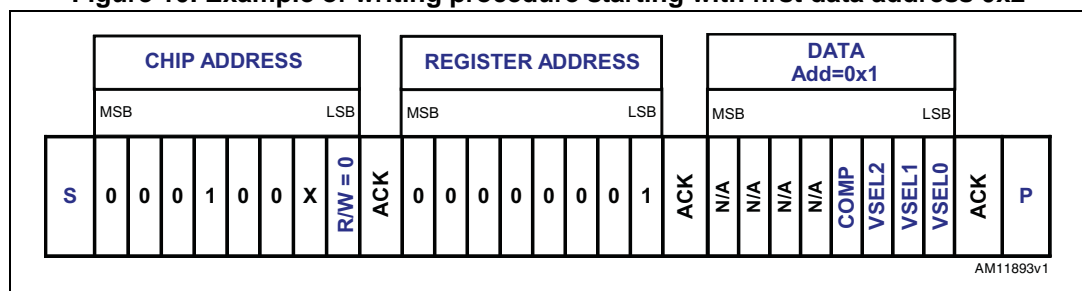

ACK = Acknowledge

S = Start

P = Stop

R/W = 1/0, Read/Write bit

X = 0/1, set the values to select the chip address (see [Table 11](#) for pin selection).

*Note:* One only DATA register address 0x1 is available for the writing procedure.

### 7.2 Read mode transmission

In Read mode the bytes sequence must be as follows:

- a start condition (S)
- a chip address byte with the LSB bit R/W=0
- the register address byte of the internal first register to be accessed
- a stop condition (P)
- a new master transmission with the chip address byte and the LSB bit R/W=1
- after the acknowledge the LNBH29 starts to send the addressed register content. As long as the master keeps the acknowledge LOW, the LNBH29 transmits the next address register byte content.
- the transmission is terminated when the master sets the acknowledge HIGH with a following stop bit.



Figure 11. Example of reading procedure starting with first status address 0X0 (a)

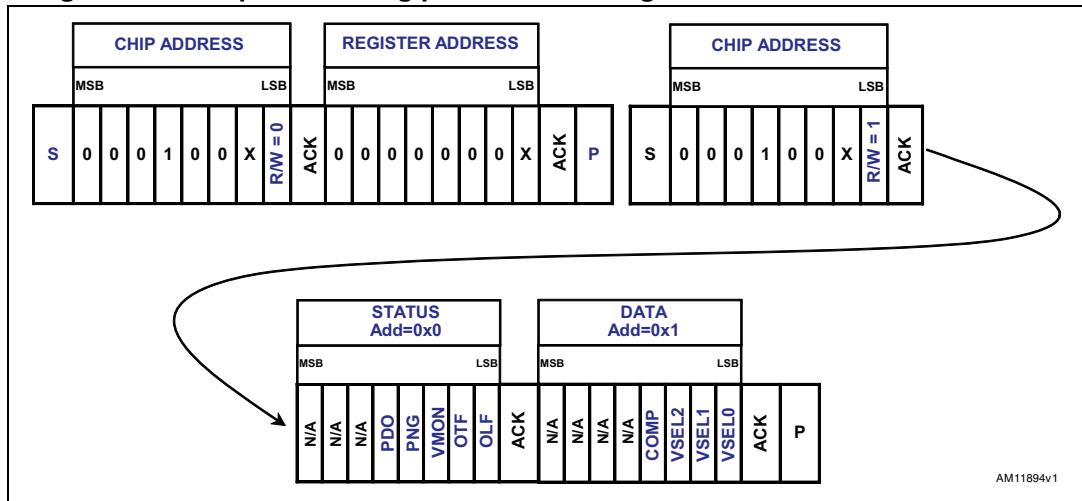

ACK = Acknowledge

S = Start

P = Stop

R/W = 1/0, Read/Write bit

X = 0/1, set the values to select the chip address (see Chip Address pin selection table) and to select the register address (0x0 for STATUS register and 0x1 for DATA register).

### 7.3 DATA register

The DATA register can be addressed both in Write and Read mode. In Read mode it returns the last writing byte status received in the previous write transmission.

Table 6 provides the DATA register values with relevant function description of each bit.

- a. The reading procedure can start from any register address (STATUS or DATA) by simply setting the X values in the register address byte (after the first chip address in Figure 11). It can be also stopped from the master by sending a stop condition after any acknowledge bit.

Table 6. DATA (READ/WRITE register. Register address = 0X1)

BIT	Name	Value	Description
Bit 0 (LSB)	VSEL0	0/1	Output voltage selection bits. (Refer to <a href="#">Table 7</a> )
Bit 1	VSEL1	0/1	
Bit 2	VSEL2	0/1	
Bit 3	COMP	1	DC-DC converter compensation: set to "1" for using very low E.S.R. capacitors or ceramic caps (V <sub>UP</sub> pin).
		0	DC-DC converter compensation: set to "0" for using standard E.S.R. capacitors (V <sub>UP</sub> pin).
Bit 4	N/A	0	Reserved. Keep to "0"
Bit 5	N/A	0	Reserved. Keep to "0"
Bit 6	N/A	0	Reserved. Keep to "0"
Bit 7 (MSB)	N/A	0	Reserved. Keep to "0"

N/A = Reserved bit.

All bits reset to "0" at power-on.

Table 7. Output voltage selection table (DATA register, Write mode)

VSEL2	VSEL1	VSEL0	V <sub>OUT</sub> min.	V <sub>OUT</sub> pin voltage	V <sub>OUT</sub> max.	Function
0	0	0		0.000		V <sub>OUT</sub> disabled. LNBH29/LNBH29E set in Standby mode
0	0	1	12.545	13.000	13.455	
0	1	0	12.867	13.333	13.800	
0	1	1	13.188	13.667	14.000	
1	0	1	17.515	18.150	18.785	
1	1	0	17.836	18.483	19.130	
1	1	1	18.158	18.817	19.475	

## 7.4 STATUS register

The STATUS register can be addressed only in Read mode and provides the diagnostic functions described in [Table 8](#).

**Table 8. STATUS (READ register. Register address = 0X0)**

BIT	Name	Value	Description
Bit 0 (LSB)	OLF	1	Output short-circuit or V <sub>OUT</sub> pin overload protection has been triggered (I <sub>OUT</sub> > I <sub>MAX</sub> ).
		0	No overload protection has been triggered to V <sub>OUT</sub> pin (I <sub>OUT</sub> < I <sub>MAX</sub> ).
Bit 1	OTF	1	Junction overtemperature is detected, T <sub>J</sub> > 150 °C.
		0	Junction overtemperature not detected, T <sub>J</sub> < 135 °C. T <sub>J</sub> is below thermal protection threshold.
Bit 2	VMON	1	Output voltage (V <sub>OUT</sub> pin) lower than V <sub>MON</sub> specification thresholds. Refer to <a href="#">Table 12</a> .
		0	Output voltage (V <sub>OUT</sub> pin) is within the V <sub>MON</sub> specifications.
Bit 3	PNG	1	Input voltage (V <sub>CC</sub> pin) lower than LPD minimum thresholds. Refer to VLP in <a href="#">Table 9</a> .
		0	Input voltage (V <sub>CC</sub> pin) higher than LPD thresholds. Refer to VLP in <a href="#">Table 9</a> .
Bit 4	PDO	1	Overcurrent detected on output pull-down stage for a time longer than de-glitch period. This may happen due to an external voltage source present on the LNB output (V <sub>OUT</sub> pin).
		0	No overcurrent detected on output pull-down stage.
Bit 5	N/A	-	Reserved
Bit 6	N/A	-	Reserved
Bit 7 (MSB)	N/A		Reserved

N/A = Reserved bit.

All bits reset to “0” at power-on.

## 8 Electrical characteristics

Refer to the [Section 5: Typical application circuits](#),  $T_J$  from 0 to 85 °C, DATA register bits set to “0” except VSEL0 = 1, RSEL = 16.2 k $\Omega$ , DSQIN = LOW,  $V_{IN}$  = 12 V,  $I_{OUT}$  = 50 mA, unless otherwise stated. Typical values are referred to  $T_J$  = 25 °C.  $V_{OUT}$  =  $V_{OUT}$  pin voltage. See software description section for I<sup>2</sup>C access to the system register ([Section 6](#) and [Section 7](#)).

**Table 9. Electrical characteristic**

Symbol	Parameter	Test conditions	Min.	Typ.	Max.	Unit
$V_{IN}$	Supply voltage <sup>(1)</sup>		8	12	17.5	V
$I_{IN}$	Supply current	$I_{OUT}$ = 0 mA		6		mA
		22 kHz tone enabled (DSQIN=high), $I_{OUT}$ = 0 mA		10		
		VSEL0=VSEL1=VSEL2=0		1		
$V_{OUT}$	Output voltage total accuracy	Valid at any $V_{OUT}$ selected level	-3.5		+3.5	%
$V_{OUT}$	Line regulation	$V_{IN}$ = 8 to 17.5 V			40	mV
$V_{OUT}$	Load regulation	$I_{OUT}$ from 50 to 500 mA			100	
$I_{MAX}$	Output current limiting thresholds	RSEL = 16.2 k $\Omega$	500		750	mA
		RSEL = 22 k $\Omega$	350		550	
$I_{SC}$	Output short-circuit current	RSEL= 16.2 k $\Omega$		400		mA
SS	Soft-start time	$V_{OUT}$ from 0 to 13 V		4		ms
SS	Soft-start time	$V_{OUT}$ from 0 to 18 V		6		ms
T13-18	Soft transition rise time	$V_{OUT}$ from 13 V to 18 V		1.5		ms
T18-13	Soft transition fall time	$V_{OUT}$ from 18 V to 13 V		1.5		ms
$T_{OFF}$	Dynamic overload protection OFF-time	Output shorted		900		ms
$T_{ON}$	Dynamic overload protection ON-time	Output shorted		$T_{OFF}/10$		
$A_{TONE}$	Tone amplitude	DSQIN = “1” (using internal tone generator) $I_{OUT}$ from 0 to 500 mA $C_{BUS}$ from 0 to 750 nF	0.55	0.675	0.8	$V_{PP}$
$F_{TONE}$	Tone frequency	DSQIN = “1” (using internal tone generator)	20	22	24	kHz
$D_{TONE}$	Tone duty cycle		43	50	57	%
$t_r, t_f$	Tone rise or fall time <sup>(2)</sup>		5	8	15	$\mu$ s
$G_{EXTM}$	External modulation gain <sup>(3)</sup>	$\Delta V_{OUT}/\Delta V_{EXTM}$ , freq. from 10 kHz to 30 kHz		10		
$V_{EXTM}$	External modulation input voltage <sup>(3)</sup>	EXTM AC coupling <sup>(4)</sup>			400	mV <sub>PP</sub>
$Z_{EXTM}$	External modulation impedance <sup>(3)</sup>			230		W

Table 9. Electrical characteristic (continued)

Symbol	Parameter	Test conditions	Min.	Typ.	Max.	Unit
Eff <sub>DC/DC</sub>	DC-DC converter efficiency	I <sub>OUT</sub> = 500 mA		93		%
F <sub>SW</sub>	DC-DC converter switching frequency			440		kHz
UVLO	Undervoltage lockout thresholds	UVLO threshold rising		4.8		V
		UVLO threshold falling		4.7		
V <sub>LP</sub>	Low power diagnostic (LPD) thresholds	V <sub>LP</sub> threshold rising		7.2		V
		V <sub>LP</sub> threshold falling		6.7		
V <sub>IL</sub>	DSQIN, pin logic LOW				0.8	V
V <sub>IH</sub>	DSQIN, pin logic HIGH		2			V
I <sub>IH</sub>	DSQIN, pin input current	V <sub>IH</sub> = 5 V		15		μA
I <sub>OBK</sub>	Output backward current	All VSELx=0 V, V <sub>OBK</sub> =30 V		-3	-6	mA
I <sub>SINK</sub>	Output low-side sink current	V <sub>OUT</sub> forced at V <sub>OUT_nom</sub> + 0.1 V		50		mA
I <sub>SINK_TIME-OUT</sub>	Low-side sink current timeout	V <sub>OUT</sub> forced at V <sub>OUT_nom</sub> + 0.1 V PDO I <sup>2</sup> C bit is set to "1" after this time has elapsed		10		ms
I <sub>REV</sub>	Max. reverse current	V <sub>OUT</sub> forced at V <sub>OUT_nom</sub> + 0.1 V, after PDO bit is set to "1" (I <sub>SINK_TIME-OUT</sub> has elapsed)		2		mA
T <sub>SHDN</sub>	Thermal shutdown threshold			150		°C
ΔT <sub>SHDN</sub>	Thermal shutdown hysteresis			15		°C

1. In applications where  $(V_{CC} - V_{OUT}) > 1.3$  V, the increased power dissipation inside the integrated LDO must be taken into account in the application thermal management design.
2. Guaranteed by design.
3. Only for type LNBH29E.
4. External signal maximum voltage for which the EXTM function is guaranteed.

T<sub>J</sub> from 0 to 85 °C, V<sub>I</sub> = 12 V.

Table 10. I<sup>2</sup>C electrical characteristics

Symbol	Parameter	Test conditions	Min.	Typ.	Max.	Unit
V <sub>IL</sub>	Low level input voltage	SDA, SCL			0.8	V
V <sub>IH</sub>	High level input voltage	SDA, SCL	2			V
I <sub>IN</sub>	Input current	SDA, SCL, V <sub>IN</sub> = 0.4 to 4.5 V	-10		10	μA
V <sub>OL</sub>	Low level output voltage	SDA (open drain), I <sub>OL</sub> = 6 mA			0.6	V
F <sub>MAX</sub>	Maximum clock frequency	SCL			400	kHz

T<sub>J</sub> from 0 to 85 °C, V<sub>I</sub> = 12 V.

**Table 11. Address pin characteristics**

Symbol	Parameter	Test condition	Min.	Typ.	Max.	Unit
V <sub>ADDR-1</sub>	“0001000(R/W)” address pin voltage range	R/W bit determines the transmission mode: read (R/W=1) write (R/W=0)	0		0.8	V
V <sub>ADDR-2</sub>	“0001001(R/W)” address pin voltage range	R/W bit determines the transmission mode: read (R/W=1) write (R/W=0)	2		5	V

Refer to [Section 5: Typical application circuits](#), T<sub>J</sub> from 0 to 85 °C, DATA register bits set to “0”, RSEL = 16 kΩ, DSQIN = LOW, V<sub>IN</sub> = 12 V, I<sub>OUT</sub> = 50 mA, unless otherwise stated. Typical values are referred to T<sub>J</sub> = 25 °C. V<sub>OUT</sub> = V<sub>OUT</sub> pin voltage. See software description section for I<sup>2</sup>C access to the STATUS register.

**Table 12. Output voltage diagnostic (VMON BIT, STATUS register) characteristics**

Symbol	Parameter	Test condition	Min.	Typ.	Max.	Unit
V <sub>TH-L</sub>	Diagnostic low threshold at V <sub>OUT</sub> = 13.0 V	VSEL0=1, VSEL1=VSEL2=0	80	90	95	%
V <sub>TH-L</sub>	Diagnostic low threshold at V <sub>OUT</sub> = 18.15 V	VSEL1=0, VSEL0=VSEL2=1	80	90	95	%

*Note:* If the output voltage is lower than the min. value the VMON I<sup>2</sup>C bit is set to 1.

If VMON = 0 then V<sub>OUT</sub> > 80% of V<sub>OUT</sub> typical.

If VMON = 1 then V<sub>OUT</sub> < 95% of V<sub>OUT</sub> typical.

## 9 Package mechanical data

In order to meet environmental requirements, ST offers these devices in different grades of ECOPACK<sup>®</sup> packages, depending on their level of environmental compliance. ECOPACK specifications, grade definitions and product status are available at: [www.st.com](http://www.st.com). ECOPACK is an ST trademark.

**Table 13. QFN16 (4 x 4 mm.) mechanical data**

Dim.	mm		
	Min.	Typ.	Max.
A	0.80	0.90	1.00
A1	0.00	0.02	0.05
A3		0.20	
b	0.25	0.30	0.35
D	3.90	4.00	4.10
D2	2.50		2.80
E	3.90	4.00	4.10
E2	2.50		2.80
e		0.65	
L	0.30	0.40	0.50

Figure 12. QFN16 (4 x 4 mm) drawing

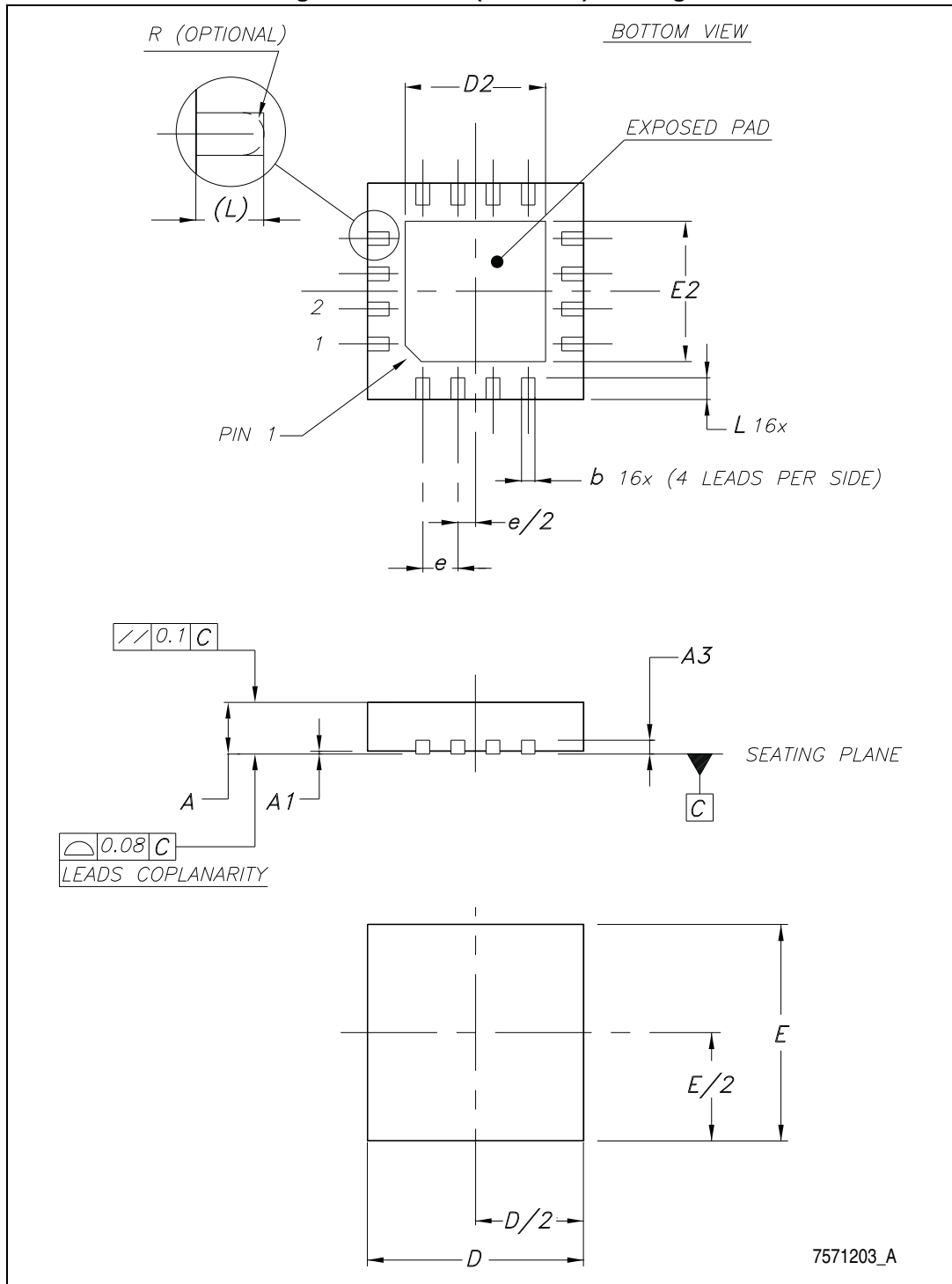
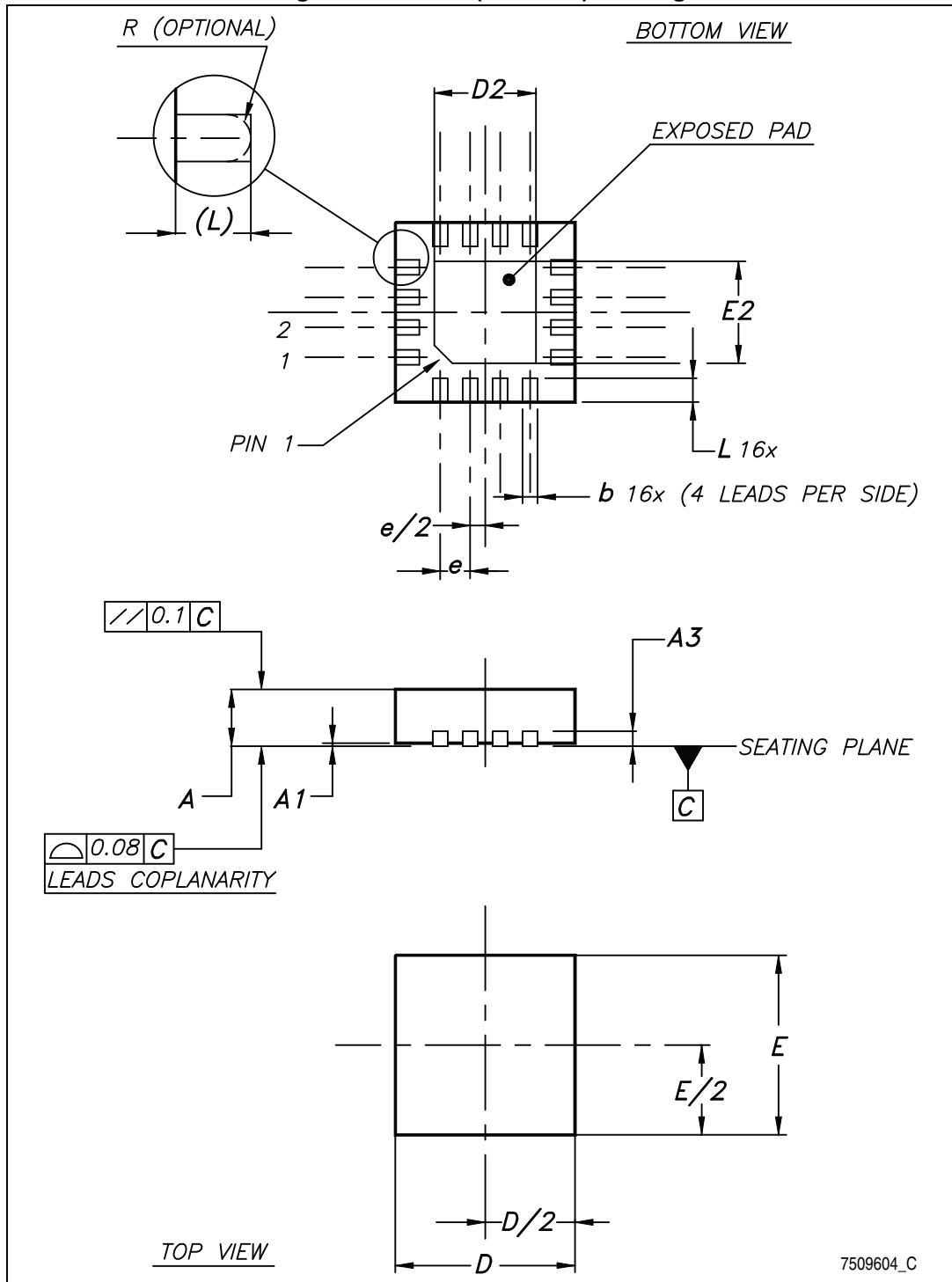



Table 14. QFN16 (3 x 3 mm) mechanical data

Dim.	mm.		
	Min.	Typ.	Max.
A	0.80	0.90	1.00
A1	0.00		0.05
A3		0.20	
b	0.18		0.30
D	2.90	3.00	3.10
D2	1.50		1.80
E	2.90	3.00	3.10
E2	1.50		1.80
e		0.50	
L	0.30		0.50

Figure 13. QFN16 (3 x 3 mm) drawing



7509604\_C

**Tape & reel QFNxx/DFNxx (4x4) mechanical data**

Dim.	mm.			inch.		
	Min.	Typ.	Max.	Min.	Typ.	Max.
A			330			12.992
C	12.8		13.2	0.504		0.519
D	20.2			0.795		
N	99		101	3.898		3.976
T			14.4			0.567
Ao		4.35			0.171	
Bo		4.35			0.171	
Ko		1.1			0.043	
Po		4			0.157	
P		8			0.315	

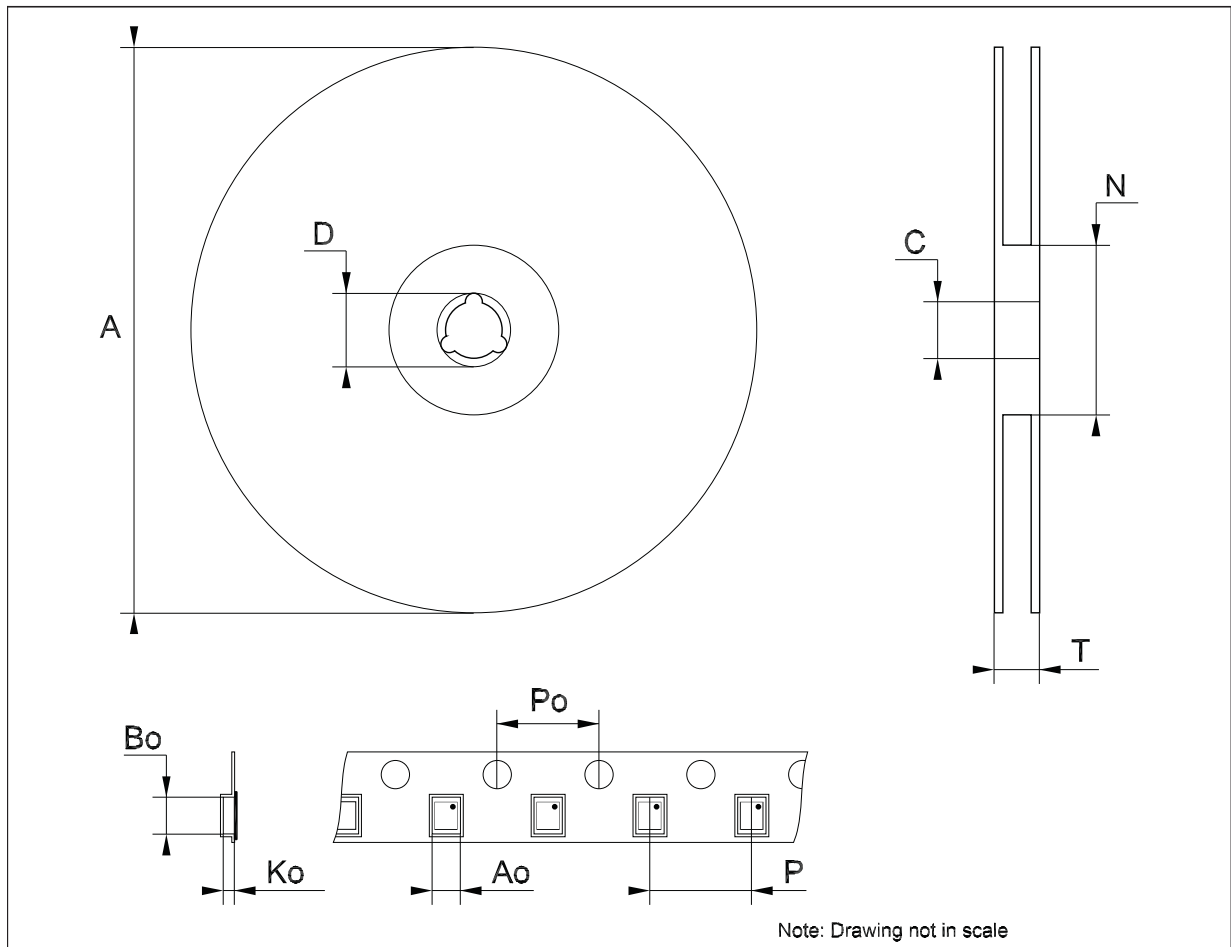

**Tape and reel QFNxx/DFNxx (3x3 mm) mechanical data**

Dim.	mm.			inch.		
	Min.	Typ.	Max.	Min.	Typ.	Max.
A			330			12.992
C	12.8		13.2	0.504		0.519
D	20.2			0.795		
N	60			2.362		
T			18.4			0.724
Ao		3.3			0.130	
Bo		3.3			0.130	
Ko		1.1			0.043	
Po		4			0.157	
P		8			0.315	

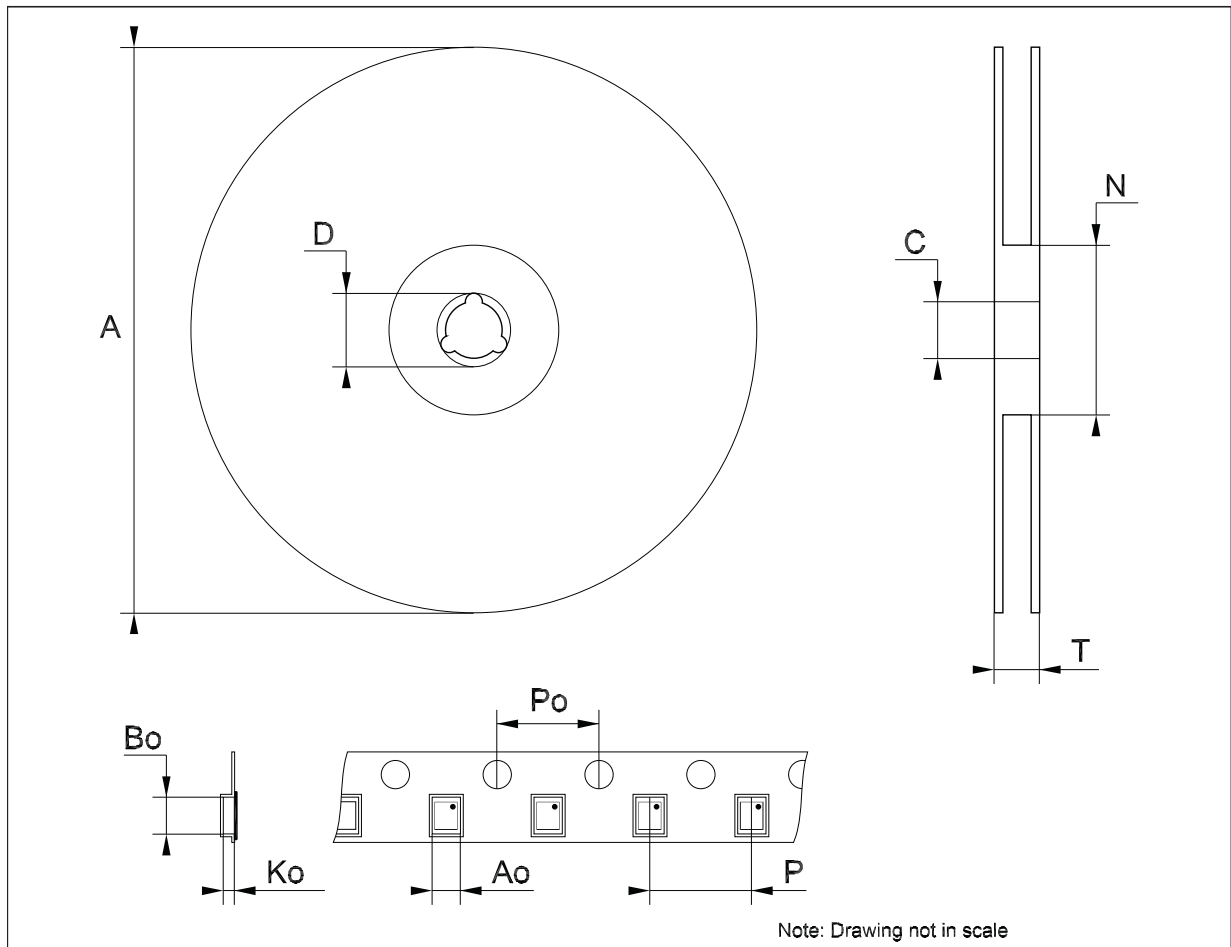

Figure 14. QFN16 (4 x 4) footprint recommended data (mm)

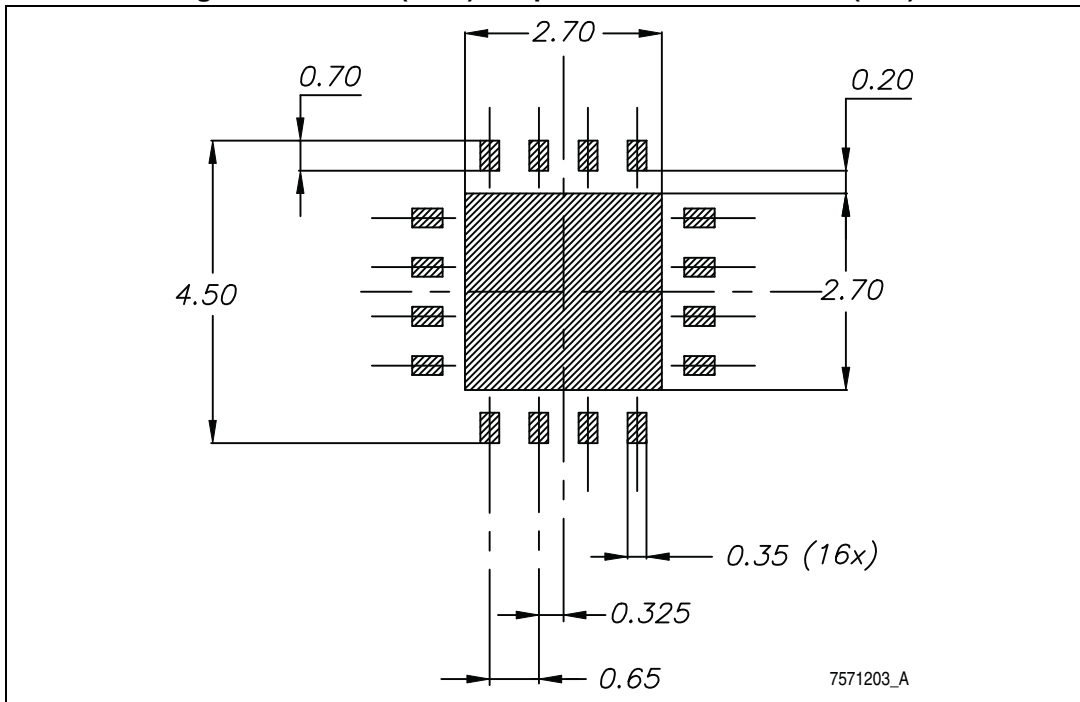
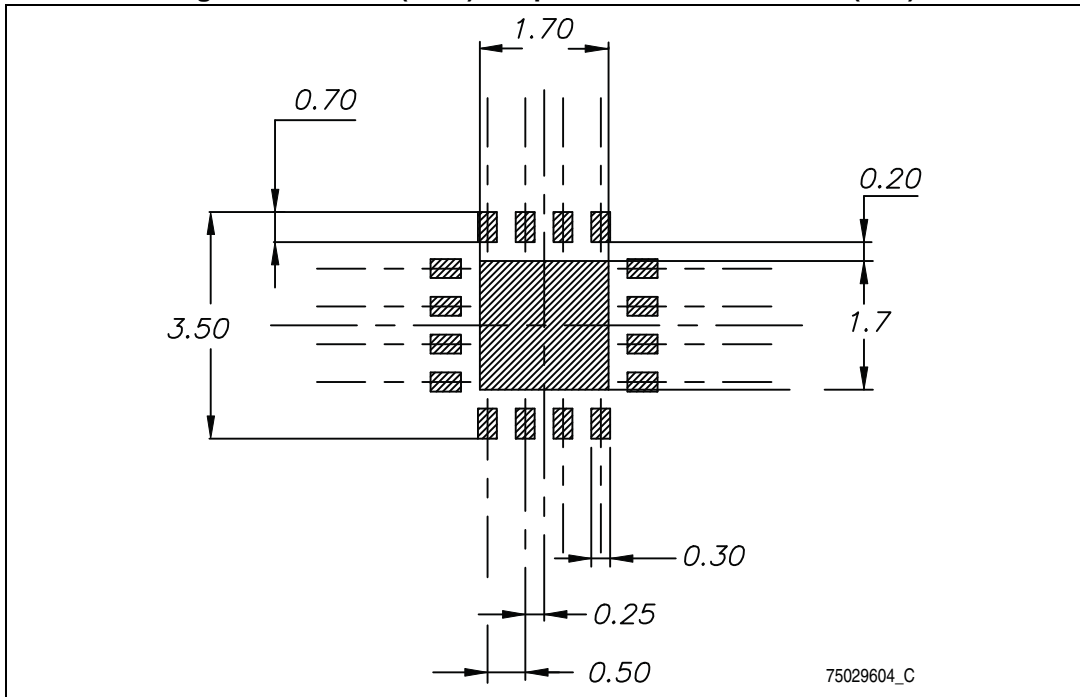

Figure 15. QFN16 (3 x 3) footprint recommended data (mm)



## 10 Revision history

**Table 15. Document revision history**

Date	Revision	Changes
03-Aug-2012	1	Initial release.
01-Oct-2012	2	Modified: L1 notes <a href="#">Table 5 on page 13</a> .
15-Mar-2013	3	Modified: Maximum clock frequency Max. value <a href="#">Table 10 on page 21</a> .

**Please Read Carefully:**

Information in this document is provided solely in connection with ST products. STMicroelectronics NV and its subsidiaries ("ST") reserve the right to make changes, corrections, modifications or improvements, to this document, and the products and services described herein at any time, without notice.

All ST products are sold pursuant to ST's terms and conditions of sale.

Purchasers are solely responsible for the choice, selection and use of the ST products and services described herein, and ST assumes no liability whatsoever relating to the choice, selection or use of the ST products and services described herein.

No license, express or implied, by estoppel or otherwise, to any intellectual property rights is granted under this document. If any part of this document refers to any third party products or services it shall not be deemed a license grant by ST for the use of such third party products or services, or any intellectual property contained therein or considered as a warranty covering the use in any manner whatsoever of such third party products or services or any intellectual property contained therein.

**UNLESS OTHERWISE SET FORTH IN ST'S TERMS AND CONDITIONS OF SALE ST DISCLAIMS ANY EXPRESS OR IMPLIED WARRANTY WITH RESPECT TO THE USE AND/OR SALE OF ST PRODUCTS INCLUDING WITHOUT LIMITATION IMPLIED WARRANTIES OF MERCHANTABILITY, FITNESS FOR A PARTICULAR PURPOSE (AND THEIR EQUIVALENTS UNDER THE LAWS OF ANY JURISDICTION), OR INFRINGEMENT OF ANY PATENT, COPYRIGHT OR OTHER INTELLECTUAL PROPERTY RIGHT.**

**ST PRODUCTS ARE NOT AUTHORIZED FOR USE IN WEAPONS. NOR ARE ST PRODUCTS DESIGNED OR AUTHORIZED FOR USE IN: (A) SAFETY CRITICAL APPLICATIONS SUCH AS LIFE SUPPORTING, ACTIVE IMPLANTED DEVICES OR SYSTEMS WITH PRODUCT FUNCTIONAL SAFETY REQUIREMENTS; (B) AERONAUTIC APPLICATIONS; (C) AUTOMOTIVE APPLICATIONS OR ENVIRONMENTS, AND/OR (D) AEROSPACE APPLICATIONS OR ENVIRONMENTS. WHERE ST PRODUCTS ARE NOT DESIGNED FOR SUCH USE, THE PURCHASER SHALL USE PRODUCTS AT PURCHASER'S SOLE RISK, EVEN IF ST HAS BEEN INFORMED IN WRITING OF SUCH USAGE, UNLESS A PRODUCT IS EXPRESSLY DESIGNATED BY ST AS BEING INTENDED FOR "AUTOMOTIVE, AUTOMOTIVE SAFETY OR MEDICAL" INDUSTRY DOMAINS ACCORDING TO ST PRODUCT DESIGN SPECIFICATIONS. PRODUCTS FORMALLY ESCC, QML OR JAN QUALIFIED ARE DEEMED SUITABLE FOR USE IN AEROSPACE BY THE CORRESPONDING GOVERNMENTAL AGENCY.**

Resale of ST products with provisions different from the statements and/or technical features set forth in this document shall immediately void any warranty granted by ST for the ST product or service described herein and shall not create or extend in any manner whatsoever, any liability of ST.

ST and the ST logo are trademarks or registered trademarks of ST in various countries.

Information in this document supersedes and replaces all information previously supplied.

The ST logo is a registered trademark of STMicroelectronics. All other names are the property of their respective owners.

© 2013 STMicroelectronics - All rights reserved

STMicroelectronics group of companies

Australia - Belgium - Brazil - Canada - China - Czech Republic - Finland - France - Germany - Hong Kong - India - Israel - Italy - Japan - Malaysia - Malta - Morocco - Philippines - Singapore - Spain - Sweden - Switzerland - United Kingdom - United States of America

[www.st.com](http://www.st.com)

