



# 12-Bit Serial Input Multiplying CMOS D/A Converter

## PM-7543

### FEATURES

- **Fast, Flexible Microprocessor Interface with Serial Data Input**
- **Superior Accuracy**  
 $\pm 1/2$  LSB INL Max  
 $\pm 1$  LSB Gain Error Max  
 Low 5ppm/°C Max Tempco
- **Improved ESD Resistance**
- **Auto-Insertable DIP Package**
- **Surface Mount SOL Package**
- **Superior Direct Replacement for AD7543**
- **-40°C to +85°C for the Extended Industrial Temperature Range**
- **Available in Die Form**

### APPLICATIONS

- **Process Control and Industrial Automation**
- **Programmable Amplifiers**
- **Digitally-Controlled Power Supplies, Attenuators, Filters**
- **Instrumentation**
- **Avionics**
- **Auto-Calibration Systems**

### ORDERING INFORMATION†

GAIN ERROR	NON-LINEARITY	TEMPERATURE RANGE		
		MILITARY*	EXTENDED <sup>†††</sup> INDUSTRIAL	COMMERCIAL
$\pm 1$ LSB	$\pm 1/2$ LSB	PM7543AQ	PM7543EQ	-
$\pm 2$ LSB	$\pm 1/2$ LSB	-	-	PM7543GP
$\pm 2$ LSB	$\pm 1$ LSB	PM7543BQ	PM7543FQ	-
$\pm 2$ LSB	$\pm 1$ LSB	PM7543BRC/883	PM7543FP	-
$\pm 2$ LSB	$\pm 1$ LSB	-	PM7543FS	-
$\pm 2$ LSB	$\pm 1$ LSB	-	PM7543FPC	-

\* For devices processed in total compliance to MIL-STD-883, add /883 after part number. Consult factory for /883 data sheet.  
 † Burn-in is available on commercial and industrial temperature range parts in CerDIP, plastic DIP, and TO-can packages.  
 †† For availability and burn-in information on SO and PLCC packages, contact your local sales office.  
 ††† CerDIP and epoxy devices are available in the extended industrial temperature range of -40°C to +85°C.

### CROSS REFERENCE

PMI	ADI	TEMPERATURE RANGE
PM7543AQ	AD7543GTD	MIL
PM7543AQ	AD7543TD	
PM7543BQ	AD7543SD	
PM7543EQ	AD7543GBD	IND
PM7543EQ	AD7543BD	
PM7543FQ	AD7543AD	
PM7543GP	AD7543GKN	COM
PM7543GP	AD7543KN	
PM7543FP	AD7543JN	
PM7543FPC	AD7543JP	

### REV. D

Information furnished by Analog Devices is believed to be accurate and reliable. However, no responsibility is assumed by Analog Devices for its use, nor for any infringements of patents or other rights of third parties which may result from its use. No license is granted by implication or otherwise under any patent or patent rights of Analog Devices.

### GENERAL DESCRIPTION

The PM-7543 is a 12-bit resolution, multiplying, CMOS D/A converter, which features serial data input and current output. Serial data input reduces pin count and allows the PM-7543 to be placed in a smaller package, saving PC board space. Improved analog parameters such as digital charge injection, power supply rejection, output capacitance, feedthrough error, fast microprocessor interface, and improved ESD protective circuitry make the PM-7543 a superior pin-compatible second-source to the industry standard AD7543.

The rising or falling edge (user selected) of the strobe inputs are used to clock serial data (present at the SRI pin) into the input shift register.

When the shift register's data has been updated, the new data word is transferred to the DAC register with use of the LOAD inputs.

*Continued*

### PIN CONNECTIONS

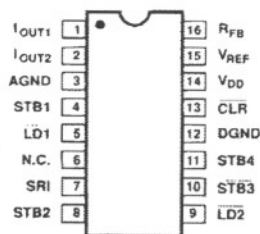

- 16-PIN EPOXY DIP (P-Suffix)
- 16-PIN CERDIP (Q-Suffix)
- 16-PIN SOL (S-Suffix)

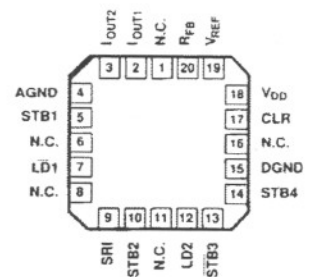

- 20-PIN LCC (RC-Suffix)
- 20-PIN PLCC (PC-Suffix)

### FUNCTIONAL BLOCK DIAGRAM

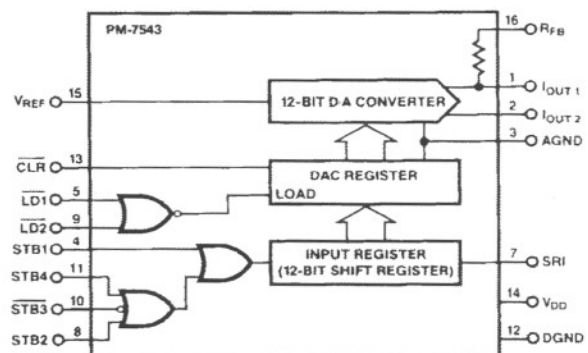

One Technology Way, P.O. Box 9106, Norwood, MA 02062-9106, U.S.A.  
 Tel: 617/329-4700 Fax: 617/326-8703 Twx: 710/394-6577  
 Telex: 924491 Cable: ANALOG NORWOODMASS

# PM-7543

## GENERAL DESCRIPTION *Continued*

Separate LOAD control inputs allow simultaneous output updating of multiple DACs. An asynchronous CLEAR input resets the DAC register without altering the data in the input register.

Improved linearity and gain error performance may permit reduced circuit parts count through the elimination of trimming components. Fast interface timing may reduce timing design considerations while minimizing microprocessor wait states. The PM-7543 is available in standard plastic and CerDIP packages that are compatible with auto-insertion equipment. For an even smaller package, consider the DAC-8043, available in an 8-pin mini-DIP.

CerDIP and epoxy devices are available in the extended industrial temperature range of -40°C to +85°C.

## ABSOLUTE MAXIMUM RATINGS ( $T_A = +25^\circ\text{C}$ , unless otherwise noted.)

$V_{DD}$ to DGND	+17V
$V_{REF}$ to DGND	$\pm 25\text{V}$
$V_{RFB}$ to DGND	$\pm 25\text{V}$
DGND to AGND	$V_{DD} + 0.3\text{V}$
AGND to DGND	$V_{DD} + 0.3\text{V}$
Digital Input Voltage Range	-0.3V to $V_{DD}$
Output Voltage (Pin 1, Pin 2)	-0.3V to $V_{DD}$

## Operating Temperature Range

AQ/BQ Versions	-55°C to +125°C
EQ/FQ/FP/FPC/FS Versions	-40°C to +85°C
GP Version	0°C to +70°C
Junction Temperature	+150°C
Storage Temperature	-65°C to +150°C
Lead Temperature (Soldering, 60 sec)	+300°C

PACKAGE TYPE	$\theta_{JA}$ (Note 1)	$\theta_{JC}$	UNITS
16-Pin Hermetic DIP (Q)	94	12	°C/W
16-Pin Plastic DIP (P)	76	33	°C/W
20-Contact LCC (RC)	88	33	°C/W
20-Pin SOL (S)	88	25	°C/W
20-Contact PLCC (PC)	73	33	°C/W

### NOTE:

- $\theta_{JA}$  is specified for worst case mounting conditions, i.e.,  $\theta_{JA}$  is specified for device in socket for CerDIP, P-DIP, and LCC packages;  $\theta_{JA}$  is specified for device soldered to printed circuit board for SOL and PLCC packages.

### CAUTION:

- Do not apply voltage higher than  $V_{DD}$  or less than DGND potential on any terminal except  $V_{REF}$  (Pin 15) and  $R_{FB}$  (Pin 16).
- The digital control input are zener-protected; however, permanent damage may occur on unprotected units from high-energy electrostatic fields. Keep units in conductive foam at all times until ready to use.
- Use proper antistatic handling procedures.
- Absolute Maximum Ratings apply to both packaged devices and DICE. Stresses above those listed under Absolute Maximum Ratings may cause permanent damage to the device.

## ELECTRICAL CHARACTERISTICS at $V_{DD} = +5\text{V}$ ; $V_{REF} = +10\text{V}$ ; $V_{OUT1} = V_{OUT2} = V_{AGND} = V_{DGND} = 0\text{V}$ ; $T_A = \text{Full Temperature Range}$ specified under Absolute Maximum Ratings, unless otherwise noted.

PARAMETER	SYMBOL	CONDITIONS	PM-7543			UNITS
			MIN	TYP	MAX	
<b>STATIC ACCURACY</b>						
Resolution	N		12	-	-	Bits
Nonlinearity (Note 1)	INL	PM-7543A/E/G PM-7543B/F	-	-	$\pm 1/2$ $\pm 1$	LSB
Differential Nonlinearity (Note 2)	DNL	PM-7543A/E PM-7543B/F/G	-	-	$\pm 1/2$ $\pm 1$	LSB
Gain Error (Note 3)	$G_{FSE}$	$T_A = +25^\circ\text{C}$ PM-7543A/E PM-7543B/F/G $T_A = \text{Full Temp. Range}$ All Grades	-	-	$\pm 1$ $\pm 2$ $\pm 2$	LSB
Gain Tempco ( $\Delta\text{Gain}/\Delta\text{Temp}$ ) (Note 6)	$TC_{GFS}$		-	-	$\pm 5$	ppm/°C
Power Supply Rejection Ratio ( $\Delta\text{Gain}/\Delta V_{DD}$ )	PSRR	$\Delta V_{DD} = \pm 5\%$	-	$\pm 0.0006$	$\pm 0.002$	%/%
Output Leakage Current (Notes 4,5)	$I_{LKG}$	$T_A = +25^\circ\text{C}$ $T_A = \text{Full Temp. Range}$ PM-7543A/B PM-7543E/F/G	-	-	$\pm 1$ $\pm 100$ $\pm 10$	nA
Zero Scale Error (Notes 8, 13)	$I_{ZSE}$	$T_A = +25^\circ\text{C}$ $T_A = \text{Full Temp. Range}$ PM-7543A/B PM-7543E/F/G	-	$\pm 0.002$ $\pm 0.05$ $\pm 0.01$	$\pm 0.006$ $\pm 0.61$ $\pm 0.06$	LSB
Input Resistance (Note 9)	$R_{IN}$	$V_{REF}$ pin	7	11	15	k $\Omega$

## PM-7543

**ELECTRICAL CHARACTERISTICS** at  $V_{DD} = +5V$ ;  $V_{REF} = +10V$ ;  $V_{OUT1} = V_{OUT2} = V_{AGND} = V_{DGND} = 0V$ ;  $T_A = \text{Full Temperature Range}$  specified under Absolute Maximum Ratings, unless otherwise noted. *Continued*

PARAMETER	SYMBOL	CONDITIONS	MIN	PM-7543 TYP	MAX	UNITS
<b>AC PERFORMANCE</b>						
Output Current Setting Time (Notes 6,7)	$t_s$		-	0.380	1	$\mu s$
AC Feedthrough Error ( $V_{REF}$ to $I_{OUT1}$ ) (Note 6, 12)	FT	$V_{REF} = 20V_{p-p}$ @ $f = 10kHz$ $T_A = +25^\circ C$	-	-	2.0	mV p-p
Digital to Analog Glitch Energy (Note 6, 11)	Q	$V_{REF} = 0V$ $I_{OUT}$ Load = $100\Omega$ $C_{EXT} = 13pF$ DAC register loaded alternately with all 0s and all 1s	-	-	20	nVs
Total Harmonic Distortion (Note 6)	THD	$V_{REF} = 6V$ RMS @ $1kHz$ DAC register loaded with all 1s	-	-	-92	dB
Output Noise Voltage Density (Notes 6, 14)	$e_n$	10Hz to 100kHz between $R_{FB}$ and $I_{OUT}$	-	-	13	nV/ $\sqrt{Hz}$
<b>DIGITAL INPUTS</b>						
Digital Input HIGH	$V_{IH}$		2.4	-	-	V
Digital Input LOW	$V_{IL}$		-	-	0.8	V
Input Leakage Current (Note 10)	$I_{IN}$	$V_{IN} = 0V$ to $+5V$	-	-	$\pm 1$	$\mu A$
Input Capacitance (Note 6)	$C_{IN}$	$V_{IN} = 0V$	-	-	8	pF
<b>ANALOG OUTPUTS</b>						
Output Capacitance (Note 6)	$C_{OUT1}$ $C_{OUT2}$	Digital Inputs = all 1s Digital Inputs = all 0s	-	-	90	pF
Output Capacitance (Note 6)	$C_{OUT1}$ $C_{OUT2}$	Digital Inputs = all 0s Digital Inputs = all 1s	-	-	60	pF
<b>TIMING CHARACTERISTICS</b>						
Serial Input to Strobe Setup Times ( $t_{STB} = 80nS$ )	$t_{DS1}$	STB1 used as the strobe	$T_A = +25^\circ C$ $T_A = \text{Full Temp. Range}$	50 50	- -	- -
	$t_{DS2}$	STB2 used as the strobe	$T_A = +25^\circ C$ $T_A = \text{Full Temp. Range}$	20 20	- -	- -
	$t_{DS3}$	STB3 used as the strobe	$T_A = +25^\circ C$ $T_A = \text{Full Temp. Range}$	10 20	- -	- -
	$t_{DS4}$	STB4 used as the strobe	$T_A = +25^\circ C$ $T_A = \text{Full Temp. Range}$	20 20	- -	- -
Serial Input to Strobe Hold Times ( $t_{STB} = 80nS$ )	$t_{DH1}$	STB1 used as the strobe	$T_A = +25^\circ C$ $T_A = \text{Full Temp. Range}$	40 50	- -	- -
	$t_{DH2}$	STB2 used as the strobe	$T_A = +25^\circ C$ $T_A = \text{Full Temp. Range}$	50 60	- -	- -
	$t_{DH3}$	STB3 used as the strobe	$T_A = +25^\circ C$ $T_A = \text{Full Temp. Range}$	80 80	- -	- -
	$t_{DH4}$	STB4 used as the strobe	$T_A = +25^\circ C$ $T_A = \text{Full Temp. Range}$	80 80	- -	- -

# PM-7543

**ELECTRICAL CHARACTERISTICS** at  $V_{DD} = +5V$ ;  $V_{REF} = +10V$ ;  $V_{OUT1} = V_{OUT2} = V_{AGND} = V_{DGND} = 0V$ ;  $T_A =$  Full Temperature Range specified under Absolute Maximum Ratings, unless otherwise noted. *Continued*

PARAMETER	SYMBOL	CONDITIONS	MIN	PM-7543 TYP	MAX	UNITS
SRI Data Pulse Width	$t_{SRI}$	$T_A =$ Full Temp. Range	100	-	-	ns
STB1 Pulse Width (STB1 = 80ns) (Note 15)	$t_{STB1}$	$T_A =$ Full Temp. Range	80	-	-	ns
STB2 Pulse Width (STB2 = 10ns) (Note 15)	$t_{STB2}$	$T_A =$ Full Temp. Range	80	-	-	ns
STB3 Pulse Width (STB3 = 80ns) (Note 15)	$t_{STB3}$	$T_A =$ Full Temp. Range	80	-	-	ns
STB4 Pulse Width (STB4 = 80ns) (Note 15)	$t_{STB4}$	$T_A =$ Full Temp. Range	80	-	-	ns
Load Pulse Width	$t_{LD1}, t_{LD2}$	$T_A = +25^\circ C$ $T_A =$ Full Temp. Range	140 180	- -	- -	ns
LSB Strobe into Input Register to Load DAC Register Time	$t_{ASB}$	$T_A =$ Full. Temp. Range	0	-	-	ns
CLR Pulse Width	$t_{CLR}$	$T_A =$ Full Temp. Range	80	-	-	ns
<b>POWER SUPPLY</b>						
Supply Voltage	$V_{DD}$		4.75	5	5.25	V
Supply Current	$I_{DD}$	All Digital Inputs = $V_{IH}$ or $V_{IL}$ All Digital Inputs = 0V or $V_{DD}$	- -	- -	2 0.1	mA

**NOTES:**

- $\pm 1/2$  LSB =  $\pm 0.012\%$  of Full Scale.
- All grades are monotonic to 12-bits over temperature.
- Using internal feedback resistor.
- Applies to  $I_{OUT1}$ ; all digital inputs =  $V_{IL}$ ,  $V_{REF} = +10V$ .
- Specification also applies for  $I_{OUT2}$  when all digital inputs =  $V_{IH}$ .
- Guaranteed by design and not tested.
- $I_{OUT1}$  Load = 100 $\Omega$ ,  $C_{EXT} = 13pF$ , digital input = 0V to  $V_{DD}$  or  $V_{DD}$  to 0V. Extrapolated to 1/2 LSB:  $t_s =$  propagation delay ( $t_{PD}$ ) + 9 $\tau$ , where  $\tau =$  measured time constant of the final RC decay.
- $V_{REF} = +10V$ , all digital inputs = 0V.
- Absolute temperature coefficient is less than +300ppm/ $^\circ C$ .
- Digital inputs are CMOS gates;  $I_{IN}$  is typically 1nA at +25 $^\circ C$ .
- $V_{REF} = 0V$ , all digital inputs = 0V to  $V_{DD}$  or  $V_{DD}$  to 0V.
- All digital inputs = 0V.
- Calculated from worst case  $R_{REF}$ :  
 $I_{ZSE}$  (in LSBs) =  $R_{REF} \times I_{LKG} \times 4096 / V_{REF}$ .
- Calculations from  $e_n = \sqrt{4K TRB}$  where:  
K = Boltzmann constant, J/ $^\circ K$     R = resistance  $\Omega$   
T = resistor temperature,  $^\circ K$     B = bandwidth, Hz
- Minimum low time pulse width for STB1, STB2, and STB4, and minimum high time pulse width for STB3.

PM-7543

DICE CHARACTERISTICS

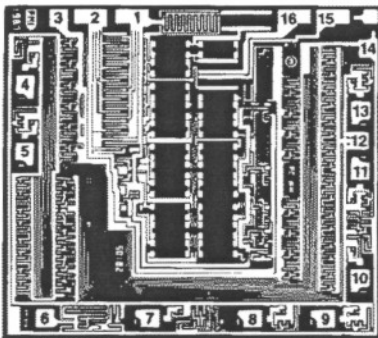

- |                      |                          |
|----------------------|--------------------------|
| 1. $I_{OUT1}$        | 9. $\overline{LD2}$      |
| 2. $I_{OUT2}$        | 10. $\overline{STB3}$    |
| 3. AGND              | 11. $\overline{STB4}$    |
| 4. $\overline{STB1}$ | 12. DGND                 |
| 5. $\overline{LD1}$  | 13. $\overline{CLR}$     |
| 6. N.C.              | 14. $V_{DD}$ (Substrate) |
| 7. SRI               | 15. $V_{REF}$            |
| 8. $\overline{STB2}$ | 16. $R_{FB}$             |

Substrate (die backside) is internally connected to  $V_{DD}$ .

DIE SIZE 0.099 x 0.107 inch, 10,543 sq. mils  
(2.51 x 2.72 mm, 6.83 sq. mm)

WAFER TEST LIMITS at  $V_{DD} = +5V$ ;  $V_{REF} = +10V$ ;  $V_{OUT1} = V_{OUT2} = V_{AGND} = V_{DGND} = 0V$ ,  $T_A = +25^\circ C$ .

PARAMETER	SYMBOL	CONDITIONS	PM-7543G LIMITS	UNITS
<b>STATIC ACCURACY</b>				
Resolution	N		12	Bits MIN
Integral Nonlinearity	INL		$\pm 1$	LSB MAX
Differential Nonlinearity	DNL		$\pm 1$	LSB MAX
Gain Error	$G_{FSE}$	Using internal feedback resistor	$\pm 2$	LSB MAX
Power Supply Rejection Ratio	PSRR	$\Delta V_{DD} = \pm 5\%$	$\pm 0.002$	%/ % MAX
Output Leakage Current ( $I_{OUT1}$ )	$I_{LKG}$	Digital Inputs = $V_{IL}$	$\pm 1$	nA MAX
<b>REFERENCE INPUT</b>				
Input Resistance	$R_{IN}$	$V_{REF}$ pad	7/15	k $\Omega$ MIN/MAX
<b>DIGITAL INPUTS</b>				
Digital Input HIGH	$V_{IH}$		2.4	V MIN
Digital Input LOW	$V_{IL}$		0.8	V MAX
Input Leakage Current	$I_{IL}$	$V_{IN} = 0V$ to $V_{DD}$	$\pm 1$	$\mu A$ MAX
<b>POWER SUPPLY</b>				
Supply Current	$I_{DD}$	Digital Inputs = $V_{IH}$ or $V_{IL}$	2.0	mA MAX
		Digital Inputs = $0V$ or $V_{DD}$	0.1	

NOTE:

Electrical tests are performed at wafer probe to the limits shown. Due to variations in assembly methods and normal yield loss, yield after packaging is not guaranteed for standard product dice. Consult factory to negotiate specifications based on dice lot qualifications through sample lot assembly and testing.

# PM-7543

## TYPICAL PERFORMANCE CHARACTERISTICS

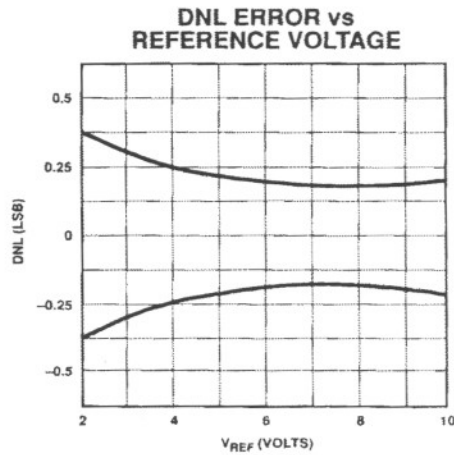
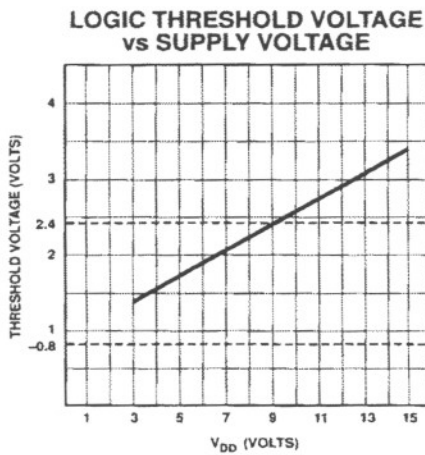
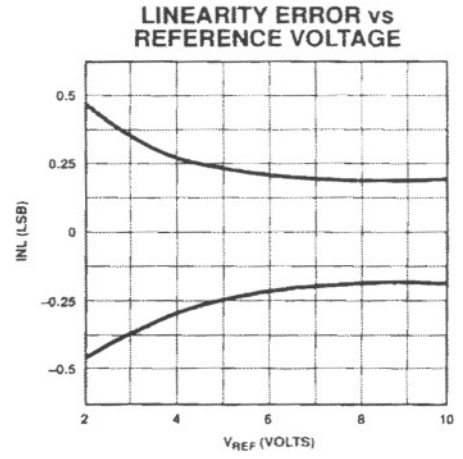
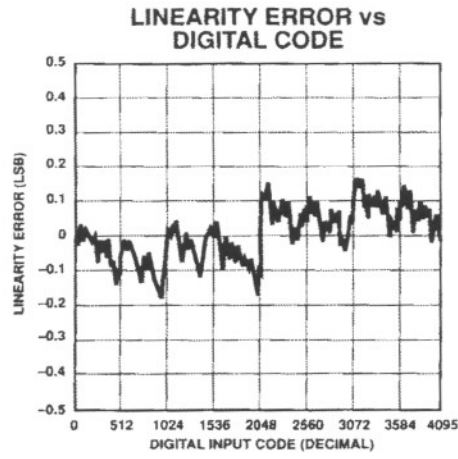
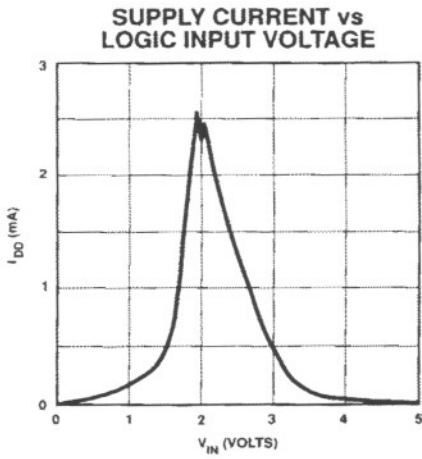
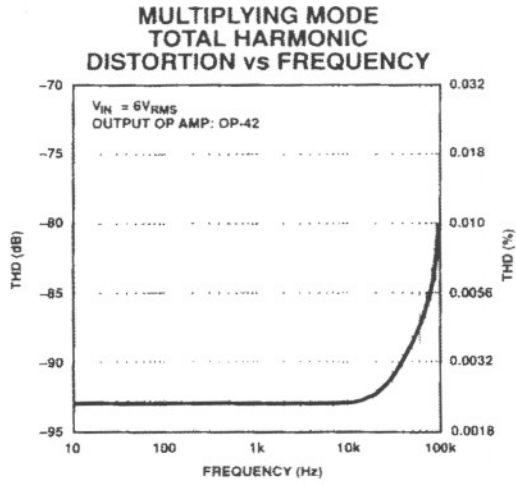
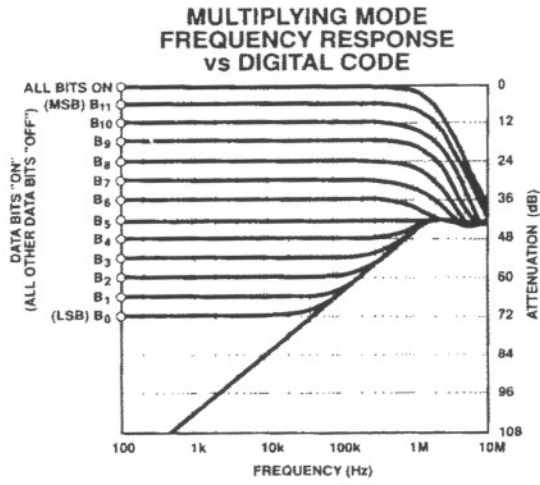

**SPECIFICATION DEFINITIONS**

**RESOLUTION**

The resolution of a DAC is the number of states ( $2^n$ ) that the full-scale range (FSR) is divided (or resolved) into, where "n" is equal to the number of bits.

**SETTLING TIME**

Time required for the analog output of the DAC to settle to within 1/2 LSB of its final value for a given digital input stimulus; i.e. zero to full scale.

**GAIN**

Ratio of the DAC's external operational amplifier output voltage to the  $V_{REF}$  input voltage when all digital inputs are HIGH.

**FEEDTHROUGH ERROR**

Error caused by capacitive coupling from  $V_{REF}$  to output. Feedthrough error limits are specified with all switches OFF.

**OUTPUT CAPACITANCE**

Capacitance from  $I_{OUT1}$  to ground.

**OUTPUT LEAKAGE CURRENT**

Current appearing at  $I_{OUT1}$  when all digital inputs are LOW, or at  $I_{OUT2}$  terminal when all inputs are HIGH.

**GENERAL CIRCUIT INFORMATION**

The PM-7543 is a 12-bit multiplying D/A converter with a very low temperature coefficient, R-2R resistor ladder network, data input and control logic, and two data registers. The digital circuitry forms an interface in which serial data can be loaded, under microprocessor control, into a 12-bit shift register and then transferred, in parallel, to the 12-bit DAC register.

An asynchronous CLEAR function allows resetting the DAC register to a zero code (0000 0000 0000) without altering data stored in the registers.

A simplified circuit of the PM-7543 DAC is shown in Figure 1. An inverted R-2R ladder network consisting of silicon-chrome, thin-film resistors, and twelve pairs of NMOS current-steering switches. These switches steer binarily weighted currents into either  $I_{OUT1}$  or  $I_{OUT2}$ . Switching current to  $I_{OUT1}$  or  $I_{OUT2}$  yields a constant current in each ladder leg, regardless of digital input code. This constant current results in a constant input resistance at  $V_{REF}$  equal to R (typically 11kΩ). The  $V_{REF}$  input may be driven by any reference voltage or current, AC or DC, that is within the limits stated in the Absolute Maximum Ratings chart.

The twelve output current-steering switches are in series with the R-2R resistor ladder, and therefore, can introduce bit errors. It was essential to design these switches such that the switch "ON" resistance be binarily scaled so that the voltage drop across each switch remains constant. If, for example, switch 1 of Figure 1 was designed with an "ON" resistance of 10 ohms, switch 2 for 20 ohms, etc., a constant 5mV drop would then be maintained across each switch.

To further insure accuracy across the full temperature range, permanently "ON" MOS switches were included in series with

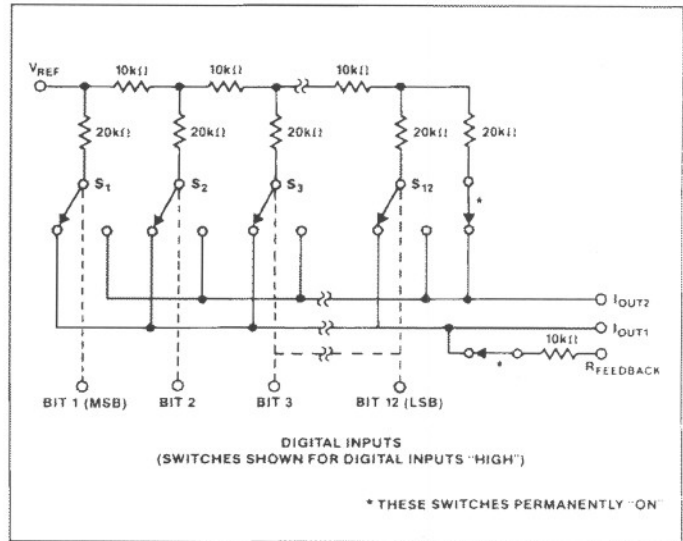

FIGURE 1: Simplified DAC Circuit

the feedback resistor and the R-2R ladder's terminating resistor. The "Simplified DAC Circuit," Figure 1, shows the location of these switches. These series switches are equivalently scaled to two times switch 1 (MSB) and to switch 12 (LSB) to maintain constant relative voltage drops with varying temperature. During any testing of the resistor ladder or  $R_{FEEDBACK}$  (such as incoming inspection),  $V_{DD}$  must be present to turn "ON" these series switches.

**ESD PROTECTION**

The PM-7543 data inputs have been designed with ESD resistance incorporated through careful layout and the inclusion of input protection circuitry.

Figure 2 shows the input protection diodes. High voltage static charges applied to the digital inputs are shunted to the supply and ground rails through forward biased diodes.

These protection diodes were designed to clamp the inputs well below dangerous levels during static discharge conditions.

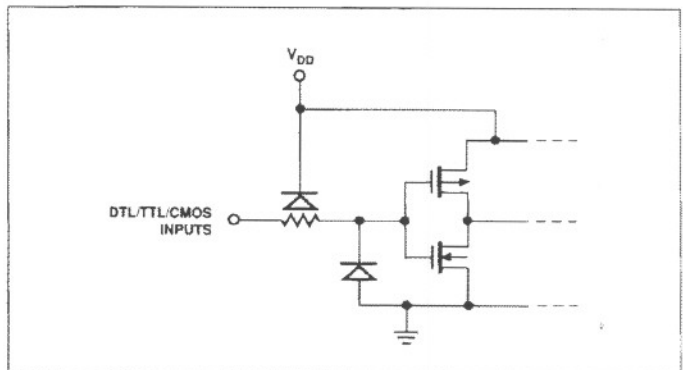

FIGURE 2: Digital Input Protection

## PM-7543

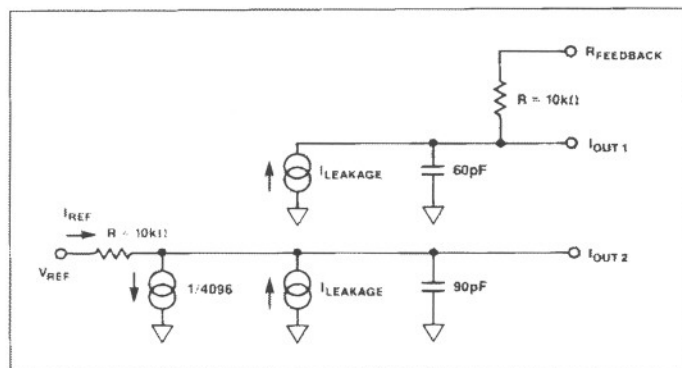

FIGURE 3: PM-7543 Equivalent Circuit (All Inputs LOW)

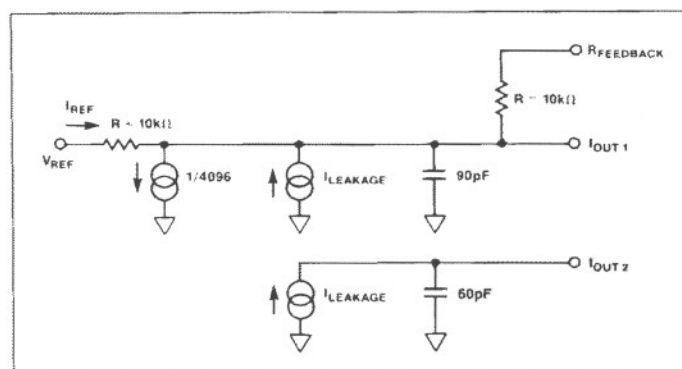

FIGURE 4: PM-7543 Equivalent Circuit (All Digital Inputs HIGH)

## EQUIVALENT CIRCUIT ANALYSIS

Figures 3 and 4 show equivalent circuits for the PM-7543's internal DAC with all bits LOW and HIGH, respectively. The reference current is switched to  $I_{OUT2}$  when all data bits are LOW, and to  $I_{OUT1}$  when all bits are HIGH. The  $I_{LEAKAGE}$  current source is the combination of surface and junction leakages to the substrate. The  $1/4096$  current source represents the constant 1-bit current drain through the ladder's terminating resistor.

Output capacitance is dependent upon the digital input code. This is because the gate capacitance of MOS transistors increases with applied gate voltage. This output capacitance varies between the low and high values.

## DYNAMIC PERFORMANCE

## OUTPUT IMPEDANCE

The output resistance, as in the case of the output capacitance, varies with the digital input code. This resistance, looking back into the  $I_{OUT1}$  terminal, may be between  $11k\Omega$  (the feedback resistor alone when all digital inputs are LOW) and  $7.5k\Omega$  (the feedback resistor in parallel with approximately  $30k\Omega$  of the R-2R ladder network resistance when any single bit logic is HIGH). Static accuracy and dynamic performance will be affected by these variations.

The gain and phase stability of the output amplifier, board layout, and power supply decoupling will all affect the dynamic performance of the PM-7543. The use of a small compensation capacitor may be required when high-speed operational amplifiers are used. It may be connected across the amplifiers feedback resistor to provide the necessary phase compensation to critically damp the output.

The considerations when using high-speed amplifiers are:

1. Phase compensation (see Figures 7 and 8).
2. Power supply decoupling at the device socket and use of proper grounding techniques.

## APPLICATIONS INFORMATION

## APPLICATION TIPS

In most applications, linearity depends upon the potential of  $I_{OUT1}$ ,  $I_{OUT2}$ , and AGND (pins 1, 2, and 3) being exactly equal to each other. In most applications, the DAC is connected to an external op amp with its noninverting input tied to ground (see Figures 7 and 8). The amplifier selected should have a low input bias current and low drift over temperature. The amplifier's input offset voltage should be nulled to less than  $\pm 200\mu V$  (less than 10% of 1 LSB).

The operational amplifier's noninverting input should have a minimum resistance connection to ground; the usual bias current compensation resistor should not be used. This resistor can cause a variable offset voltage appearing as a varying output error. All grounded pins should tie to a single common ground point, avoiding ground loops. The  $V_{DD}$  power supply should have a low noise level with no transients greater than  $+17V$ .

It is recommended that the digital inputs be taken to ground or  $V_{DD}$  via a high value ( $1M\Omega$ ) resistor; this will prevent the accumulation of static charge if the PC card is disconnected from the system.

Peak supply current flows as the digital inputs pass through the transition region (see the Supply Current vs Logic Input Voltage graph under the Typical Performance Characteristics). The supply current decreases as the input voltage approaches the supply rails ( $V_{DD}$  or DGND), i.e. rapidly slewing logic signals that settle very near the supply rails will minimize supply current.

## OUTPUT AMPLIFIER CONSIDERATIONS

When using high speed op amps, a small feedback capacitor (typically 5-30pF) should be used across the amplifier to minimize overshoot and ringing. For low speed or static applications, AC specifications of the amplifier are not very critical. In high-speed applications, slew rate, settling time, open-loop gain, and gain/phase margin specifications of the amplifier should be selected for the desired performance. It has already been noted that an offset can be caused by including the usual bias current compensation resistor in the amplifier's noninverting input terminal. This resistor should not be used. Instead, the amplifier should have a bias current which is low over the temperature range of interest.



**PM-7543**

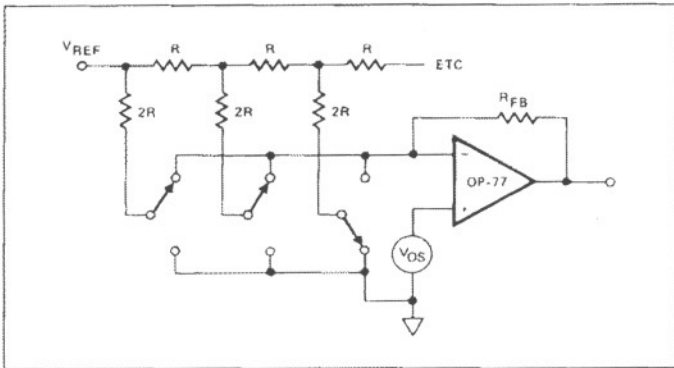

**FIGURE 5: Simplified Circuit**

Static accuracy is affected by the variation in the DAC's output resistance. This variation is best illustrated by using the circuit of Figure 5 and the equation:

$$V_{ERROR} = V_{OS} \left( 1 + \frac{R_{FB}}{R_O} \right)$$

where  $R_O$  is a function of the digital code, and:

- $R_O = 10k\Omega$  for more than four bits of logic 1,
- $R_O = 30k\Omega$  for any single bit of logic 1.

Therefore, the offset gain varies as follows:

at code 0011 1111 1111,

$$V_{ERROR1} = V_{OS} \left( 1 + \frac{10k\Omega}{10k\Omega} \right) = 2 V_{OS}$$

at code 0100 0000 0000,

$$V_{ERROR2} = V_{OS} \left( 1 + \frac{10k\Omega}{30k\Omega} \right) = 4/3 V_{OS}$$

The error difference is  $2/3 V_{OS}$ .

Since one LSB has a weight (for  $V_{REF} = +10V$ ) of 2.4mV for the PM-7543, it is clearly important that  $V_{OS}$  be minimized, either using the amplifier's nulling pins, an external nulling network, or by selection of

an amplifier with inherently low  $V_{OS}$ . Amplifiers with sufficiently low  $V_{OS}$  include PMI's OP-77, OP-97, OP-07, OP-27 and OP-42.

**INTERFACE LOGIC OPERATION**

The microprocessor interface of the PM-7543 has been designed with multiple STROBE and LOAD inputs to maximize interfacing options. Control signals decoding may be done on-chip or with the use of external decoding circuitry (see Figure 11).

Serial data can be clocked into the input register with STB1, STB2, or STB4. The strobe inputs are active on the rising edge. STB3 may be used with a falling edge to clock-in data.

Holding any STROBE input at its selected state (i.e. STB1, STB2 or STB4 at logic HIGH or STB3 at logic LOW) will act to prevent any further data input.

When a new data word has been entered into the input register, it is transferred to the DAC register by asserting both LOAD inputs.

The CLR input allows asynchronous resetting of the DAC register to 0000 0000 0000. This reset does not affect data held in the input registers. While in unipolar mode, a CLEAR will result in the analog output going to 0V. In bipolar mode, the output will go to  $-V_{REF}$ .

**INTERFACE INPUT DESCRIPTION**

**STB1 (Pin 4), STB2 (Pin 8), STB4 (Pin 11) – Input Register Strobe. Inputs Active on Rising Edge.** Selected to load serial data into input register. See Table 1 for details.

**STB3 (Pin 10) – Input Register Strobe Input. Active on Falling Edge.** Selected to load serial data into input register. See Table 1 for details.

**LD1 (Pin 5), LD2 (Pin 9) – Load DAC Register Inputs. Active Low.** Selected together to load contents of Input Register into DAC register.

**CLR (Pin 13) – Clear Input. Active Low. Asynchronous.** When LOW, 12-bit DAC register is forced to a zero code (0000 0000 0000) regardless of other interface inputs.

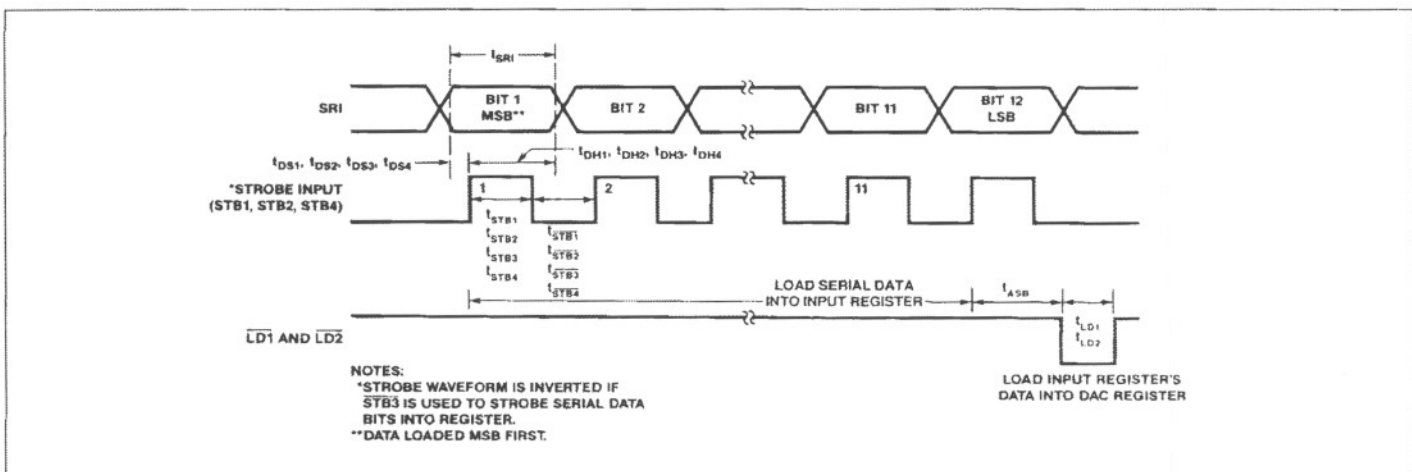

**FIGURE 6: Timing Diagram**

# PM-7543

TABLE 1: PM-7543 Truth Table

PM-7543 Logic Inputs							PM-7543 Operation	Notes
Input Register		Control Inputs		DAC Register		Control Inputs		
STB4	STB3	STB2	STB1	CLR	LD2	LD1		
0	1	0	$\uparrow$	X	X	X	Serial Data Bit Loaded from SRI into Input Register	2,3
0	1	$\uparrow$	0	X	X	X		
0	$\downarrow$	0	0	X	X	X		
$\uparrow$	1	0	0	X	X	X		
1	X	X	X				No Operation (Input Register)	3
X	0	X	X					
X	X	1	X					
X	X	X	1					
				0	X	X	Reset DAC Register to Zero Code (Code: 0000 0000 0000) (Asynchronous Operation)	1,3
				1	1	X	No Operation (DAC Register)	3
				1	X	1		
				1	0	0	Load DAC Register with the Contents of Input Register	3

**NOTES:**

1. CLR = 0 Asynchronously resets DAC Register to 0000 0000 0000, but has no effect on Input Register.
2. Serial data is loaded into Input Register MSB first, on edges shown  $\uparrow$  is positive edge,  $\downarrow$  is negative edge.
3. 0 = Logic LOW, 1 = Logic HIGH, X = Don't Care.

**UNIPOLAR OPERATION (2-QUADRANT)**

The circuit shown in Figures 7 and 8 may be used with an AC or DC reference voltage. The circuit's output will range between 0V and approximately  $-V_{REF}$  (4095/4096) depending upon the digital input code. The relationship between the digital input and the analog output is shown in Table 2. The  $V_{REF}$  voltage range is the maximum input voltage range of the op amp or  $\pm 25V$ , whichever is lowest.

In many applications the PM-7543's negligible zero scale error and very low gain error permit the elimination of the trimming of the components ( $R_1$  and the external  $R_{FEEDBACK}$ ) without adverse effects on circuit performance.

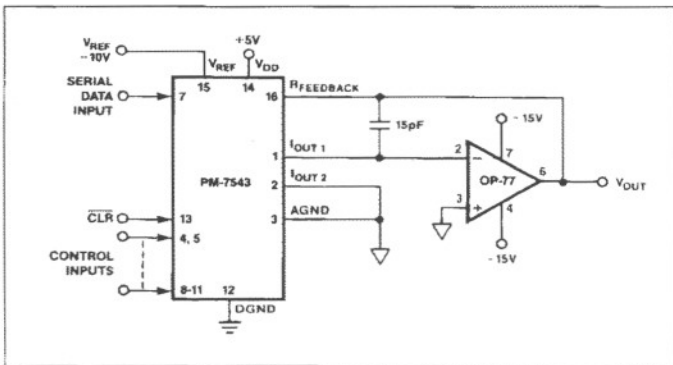

FIGURE 7: Unipolar Operation with High Accuracy Op Amp (2-Quadrant)

TABLE 2: Unipolar Code Table

DIGITAL INPUT			NOMINAL ANALOG OUTPUT
MSB		LSB	( $V_{OUT}$ as shown in Figures 7 and 8)
1	1 1 1	1 1 1 1	$-V_{REF} \left( \frac{4095}{4096} \right)$
1	0 0 0	0 0 0 1	$-V_{REF} \left( \frac{2049}{4096} \right)$
1	0 0 0	0 0 0 0	$-V_{REF} \left( \frac{2048}{4096} \right) = -\frac{V_{REF}}{2}$
0	1 1 1	1 1 1 1	$-V_{REF} \left( \frac{2047}{4096} \right)$
0	0 0 0	0 0 0 1	$-V_{REF} \left( \frac{1}{4096} \right)$
0	0 0 0	0 0 0 0	$-V_{REF} \left( \frac{0}{4096} \right) = 0$

**NOTES:**

1. Nominal full scale for the circuits of Figures 7 and 8 is given by  $FS = -V_{REF} \left( \frac{4095}{4096} \right)$ .
2. Nominal LSB magnitude for the circuits of Figures 7 and 8 is given by  $LSB = V_{REF} \left( \frac{1}{4096} \right)$  or  $V_{REF} (2^{-n})$ .

For applications requiring a tighter gain error than 0.024% at 25°C for the top grade part, or 0.048% for the lower grade part, the circuit in Figure 8 may be used. Gain error may be trimmed by adjusting  $R_1$ .

# PM-7543

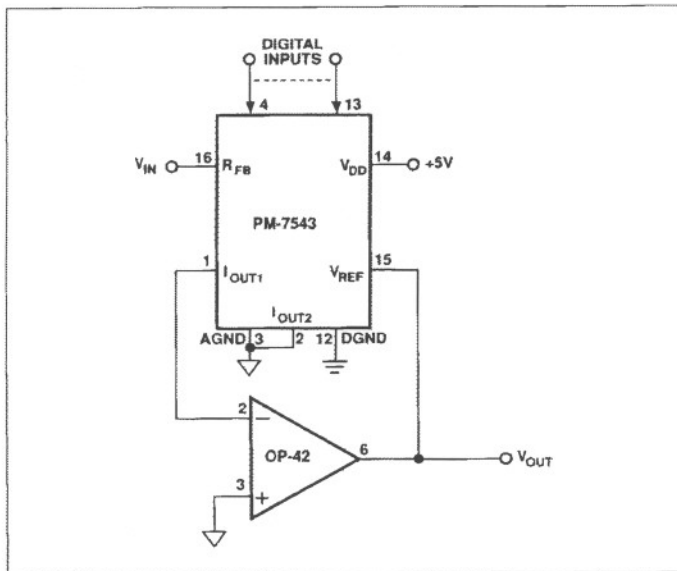

FIGURE 10: Analog/Digital Divider

The transfer function is modified when the DAC is connected in the feedback of an operational amplifier as shown in Figure 10 and is:

$$V_O = \left( \frac{-V_{IN}}{\frac{A_1}{2^1} + \frac{A_2}{2^2} + \frac{A_3}{2^3} + \dots + \frac{A_{12}}{2^{12}}} \right)$$

The above transfer function is the division of an analog voltage ( $V_{REF}$ ) by a digital word. The amplifier goes to the rails with all bits "OFF" since division by zero is infinity. With all bits "ON," the gain is 1 ( $\pm 1$  LSB). The gain becomes 4096 with the LSB, bit 12, "ON."

### INTERFACING TO THE MC6800

As shown in Figure 11, the PM-7543 may be interfaced to the 6800 by successively executing memory WRITE instructions while manipulating the data between WRITES, so that each WRITE presents the next bit.

In this example, the most significant bits are found in memory locations 0000 and 0001. The four MSBs are found in the lower half of 0000, the eight LSBs in 0001. The data is taken from the  $DB_7$  line.

The serial data loading is triggered by STB1 which is asserted by a decoded memory WRITE to a memory location, R/W, and  $\phi 2$ . A WRITE to another address location transfers data from input register to DAC register.

### PM-7543 INTERFACE TO THE 8085

The PM-7543's interface to the 8085 microprocessor is shown in Figure 12. Note that the microprocessor's SOD line is used to present data serially to the DAC.

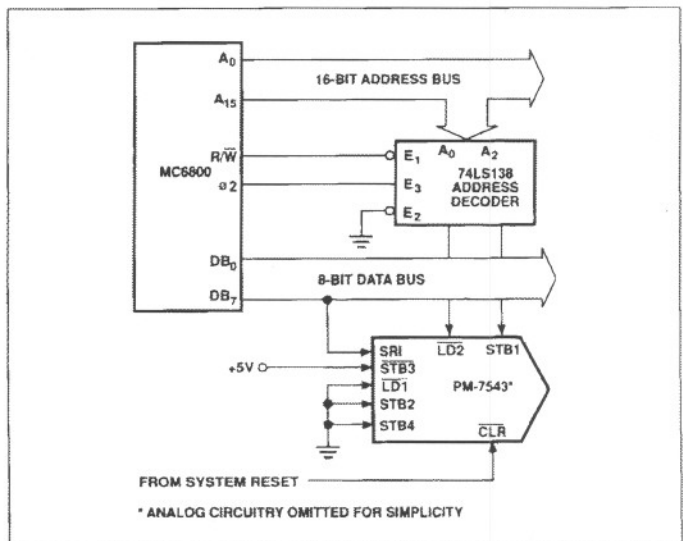

FIGURE 11: PM-7543 - MC6800 Interface

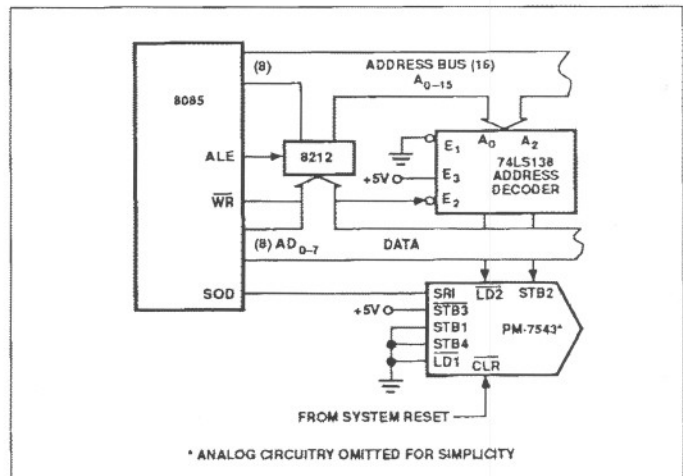

FIGURE 12: PM-7543 - 8085 Interface

Data is strobed into the PM-7543 by executing memory write instructions. The strobe 2 input is generated by decoding an address location and  $\overline{WR}$ . Data is loaded into the DAC register with a memory write instruction to another address location.

Serial data supplied to the PM-7543 must be present in the right-justified format in registers H and L of the microprocessor.

Chain ID	MktName	AppName	1st Ten	11_20	21_30	31_49
1001	Audio	Computer Audio				X
1002	Audio	Consumer Audio/Speaker Phone			X	
1003	Audio	Pro Audio				X
1043	Audio	Speech		X		
1044	Automotive	High-Side Current Sense				X
1045	Automotive	Telematics System	#			
1004	Communications (Wired)	Cable Modem		X		
1005	Communications (Wired)	Modem				X
1006	Communications (Wired)	Networking (Wired)			X	
1007	Communications (Wired)	Set-top Box	#			
1008	Communications (Wired)	Video Conferencing		X		
1009	Communications (Wired)	xDSL				X
1042	Communications (Wired)	Home Power Line Modem				X
1046	Communications (Wired)	Voice Over IP				X
1010	(Wireless)	Basestation		X		
1011	(Wireless)	Handset/Soft Cell				X
1012	(Wireless)	Networking (Wireless)			X	
1047	(Wireless)	PDA	#			
1013	Computer	Disk Drive				X
1014	Computer	Motherboard		X		
1015	Imaging/Video	Camcorder			X	
1016	Imaging/Video	Digital Camera	#			
1017	Imaging/Video	Digital Video		X		
1018	Imaging/Video	Document Scanner/Fax				X
1019	Imaging/Video	Video Capture Board	#			
1020	Industrial	Flow Metering			X	
1021	Industrial	Machine Vision		X		
1022	Industrial	Measurement/Process Control	#			
1023	Industrial	Motor Control			X	
1024	Industrial	Vibration Analysis				X
1025	Industrial	Weigh Scale		X		
1026	Instrumentation	ATE Equipment				X
1027	Instrumentation	Data Acquisition			X	
1028	Instrumentation	Digital Storage Scope				X
1029	Instrumentation	Portable System Tester				X
1030	Instrumentation	Signal Source		X		
1031	Instrumentation	Spectrum Analyzer	#			
1032	Medical	Blood Analyzer			X	
1033	Medical	ECG/EKG	#			
1034	Medical	Medical Imaging/Ultrasound		X		
1035	Medical	Patient Monitor				X
1048	Medical	CAT Scanner			X	
1036	Military/Aerospace	Communications				X
1037	Optical Networking	Fiber EDFA	#			
1038	Optical Networking	Fiber Cross-Connect				X
1039	Optical Networking	RX Solution	#			
1040	Optical Networking	TX Solution				X
1041	Optical Networking	Fiber EDFA (High-Power)				X
1049	Optical Networking	Optical Test Equipment			X	
NOTE: 1ST ten live; 21-30 end of July/1st of August; all 49 needed for Matrix 3.0 release end of June 03						

**PM-7543**

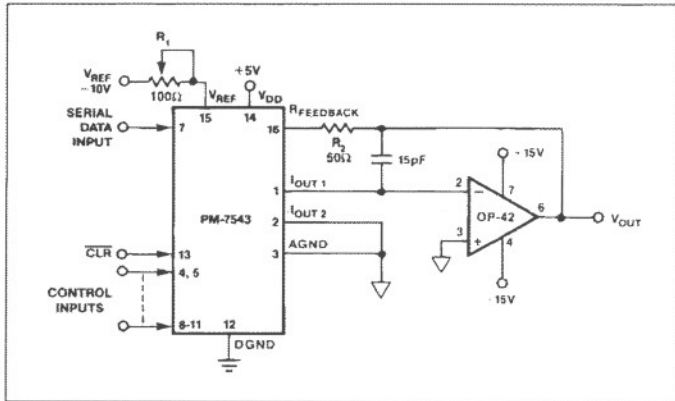

**FIGURE 8:** Unipolar Operation with Fast Op Amp and Gain Error Trimming (2-Quadrant)

The DAC register must first be loaded with all 1s.  $R_1$  is then adjusted until  $V_{OUT} = -V_{REF}$  (4095/4096). In the case of an adjustable  $V_{REF}$ ,  $R_1$  and  $R_{FEEDBACK}$  may be omitted, with  $V_{REF}$  adjusted to yield the desired full-scale output.

**BIPOLAR OPERATION (4-QUADRANT)**

Figure 9 details a suggested circuit for bipolar, or offset binary operation. Table 3 shows the digital input to analog output relationship. The circuit uses offset binary coding. Two's complement code can be converted to offset binary by software inversion of the MSB or by the addition of an external inverter to the MSB input.

Resistors  $R_3$ ,  $R_4$ , and  $R_5$  must be selected to match within 0.01% and must all be of the same (preferably metal foil) type to assure temperature coefficient match. Mismatching between  $R_3$  and  $R_4$  causes offset and full-scale errors while an  $R_5$  to  $R_4$  and  $R_3$  mismatch will result in full-scale error.

Calibration is performed by loading the DAC register with 1000 0000 0000 and adjusting  $R_1$  until  $V_{OUT} = 0V$ .  $R_1$  and  $R_2$  may be omitted by

**TABLE 3:** Bipolar (Offset Binary) Code Table

DIGITAL INPUT			NOMINAL ANALOG OUTPUT
MSB	LSB		( $V_{OUT}$ as shown in Figure 9)
1 1 1 1	1 1 1 1	1 1 1 1	$+V_{REF} \left( \frac{2047}{2048} \right)$
1 0 0 0	0 0 0 0	0 0 0 1	$+V_{REF} \left( \frac{1}{2048} \right)$
1 0 0 0	0 0 0 0	0 0 0 0	0
0 1 1 1	1 1 1 1	1 1 1 1	$-V_{REF} \left( \frac{1}{2048} \right)$
0 0 0 0	0 0 0 0	0 0 0 1	$-V_{REF} \left( \frac{2047}{2048} \right)$
0 0 0 0	0 0 0 0	0 0 0 0	$-V_{REF} \left( \frac{2048}{2048} \right)$

**NOTES:**

- Nominal full scale for the circuits of Figure 9 is given by  $FS = V_{REF} \left( \frac{2047}{2048} \right)$ .
- Nominal LSB magnitude for the circuits of Figure 9 is given by  $LSB = V_{REF} \left( \frac{1}{2048} \right)$ .

adjusting the ratio of  $R_3$  to  $R_4$  to yield  $V_{OUT} = 0V$ . Full scale can be adjusted by loading the DAC register with 1111 1111 1111 and either adjusting the amplitude of  $V_{REF}$  or the value of  $R_5$  until the desired  $V_{OUT}$  is achieved.

**ANALOG/DIGITAL DIVISION**

The transfer function for the PM-7543 connected in the multiplying mode as shown in Figures 7 and 8 is:

$$V_O = -V_{IN} \left( \frac{A_1}{2^1} + \frac{A_2}{2^2} + \frac{A_3}{2^3} + \dots + \frac{A_{12}}{2^{12}} \right)$$

where  $A_x$  assumes a value of 1 for an "ON" bit and 0 for an "OFF" bit.

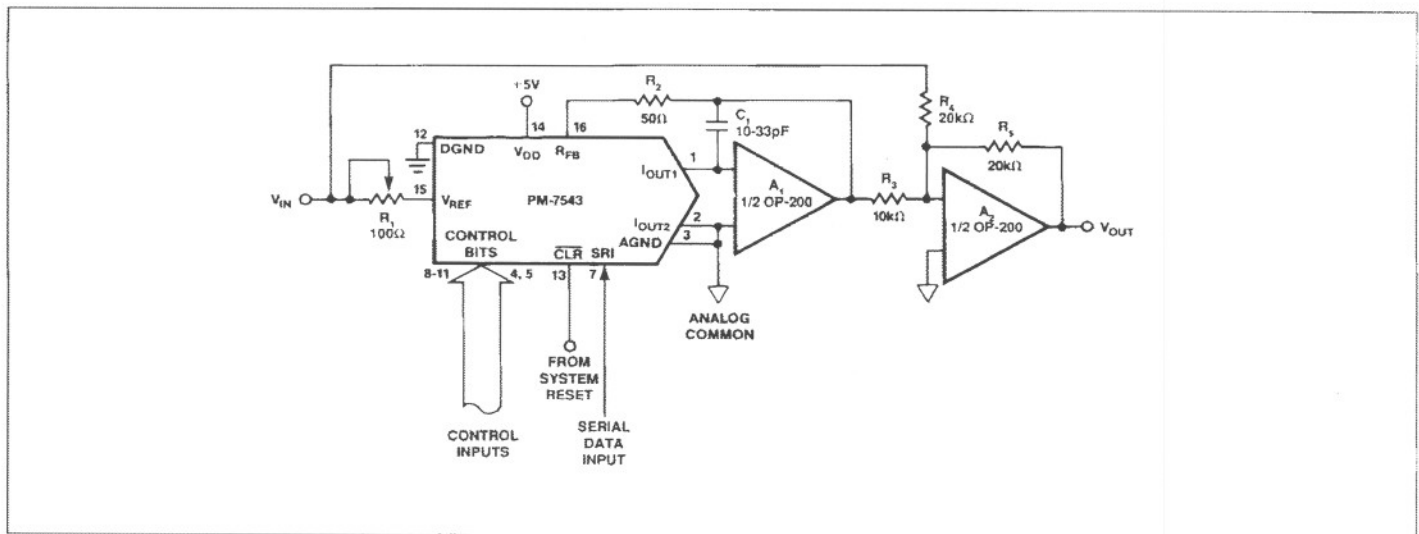

**FIGURE 9:** Bipolar Operation (4-Quadrant, Offset Binary)