

Nov.1.2016 Copyright 2016 HIROSE ELECTRIC CO., LTD. All Rights Reserved.

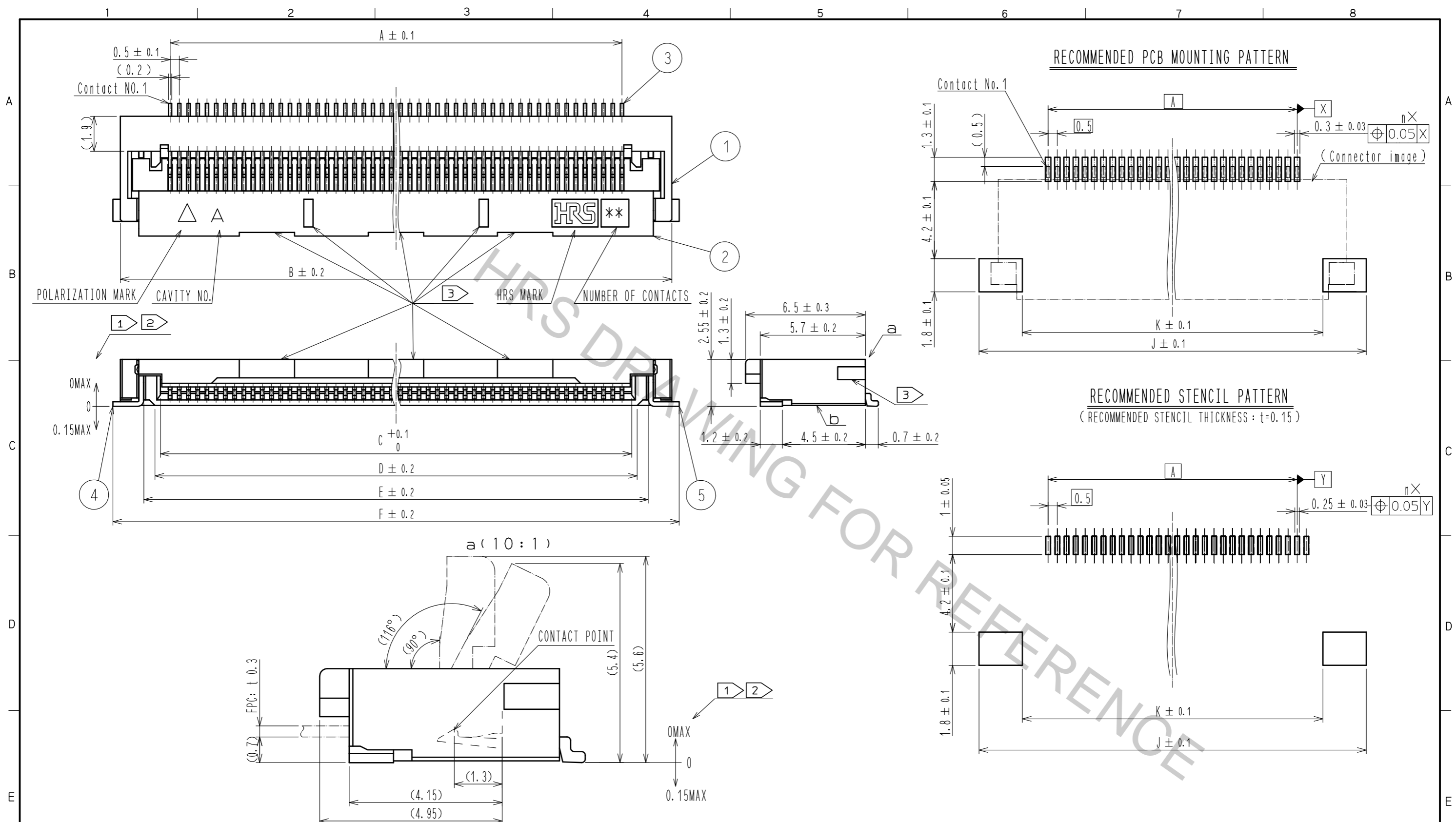

- NOTES
- ① Lead CO-PLANARITY including reinforced metal fittings shall be 0.1 MAX.
 - ② Dimension: from reference b.
 - ③ Indicates notches or holes to prevent sink marks. The design and the location are discretionary, depending on the number of contacts.
 - 4. This product satisfies halogen free requirements defined as 900ppm maximum chlorine, 900ppm maximum bromine, and 1500ppm maximum total of chlorine and bromine.
 - 5. 'n' represents the number of contacts.
 - 6. The dimensions in parentheses are for reference.

5	BRASS	TIN PLATING 1#mMIN OVER NICKEL 1#mMIN						
4	BRASS	TIN PLATING 1#mMIN OVER NICKEL 1#mMIN	9	(CONNECTOR)				
3	PHOSPHOR BRONZE	GOLD PLATING 0.05#mMIN OVER NICKEL 1#mMIN	8	POLYSTYRENE				
2	LCP	(BLACK) UL94V-0	7	POLYESTER				
1	LCP	(GRAY) UL94V-0	6	POLYSTYRENE				
NO.	MATERIAL	FINISH . REMARKS	NO.	MATERIAL	FINISH . REMARKS			
UNITS	mm	SCALE	5 : 1	COUNT	DESCRIPTION OF REVISIONS	DESIGNED	CHECKED	DATE
APPROVED		: NF. MIYAZAKI		15. 10. 17		DRAWING NO. EDC-156370-05-05		
CHECKED		: HS. SAKAMOTO		15. 10. 17		PART NO. FH28E-*S-0.5SH(C05)		
DESIGNED		: RT. IKEDA		15. 10. 17		CODE NO. CL586		
DRAWN		: RN. IIDA		15. 10. 15		1/4		

Nov.1.2016 Copyright 2016 HIROSE ELECTRIC CO., LTD. All Rights Reserved.

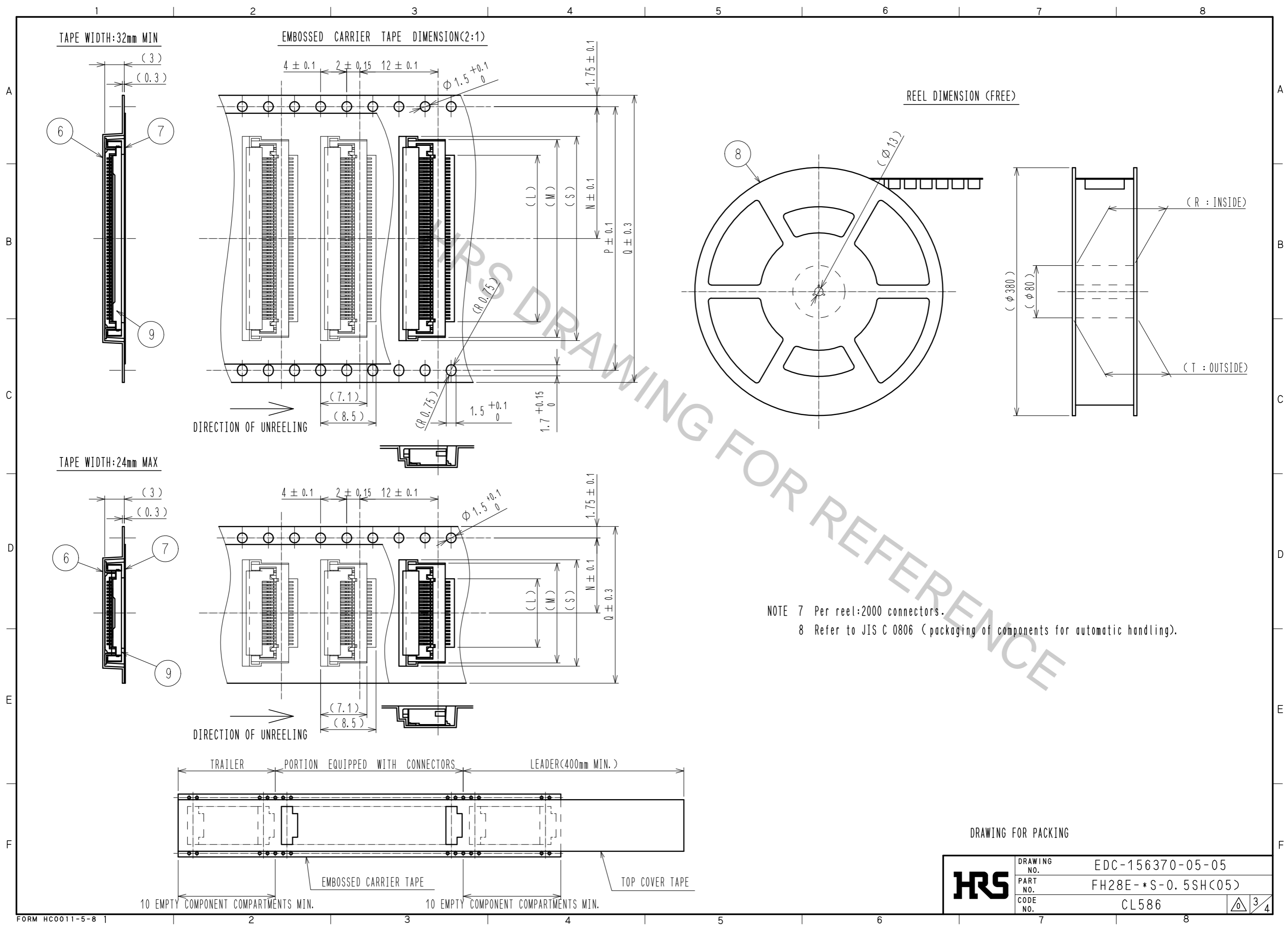

HRS	DRAWING NO.	EDC-156370-05-05
	PART NO.	FH28E-*S-0.5SH<05>
	CODE NO.	CL586
		\triangle 3/4

1 2 3 4 5 6 7 8

A
B
C
D
E
F

A
B
C
D
E
F

HRS DRAWING REFERENCE

PART NO.	CODE NO.	Number of contact	DIMENSION TABLE OF CONNECTOR, FPC, FFC, LAND PATTERN AND STENCIL PATTERN										DIMENSION TABLE OF DRAWING FOR PACKING							
			A	B	C	D	E	F	G	H	J	K	L	M	N	P	Q	R	T	S
FH28E-20S-0.5SH(05)	CL580-1822-2-05	20	9.5	14.9	10.57	11.15	12.35	15.7	10.5	12.1	16.7	12	10.5	15.3	11.5	-	24	25.4	29.4	16.3
FH28E-30S-0.5SH(05)	CL580-1833-9-05	30	14.5	19.9	15.57	16.15	17.35	20.7	15.5	17.1	21.7	17	15.5	20.3	14.2	28.4	32	33.4	37.4	21.3
⑨ FH28E-40S-0.5SH(07)	CL580-1814-4-07	40	19.5	24.9	20.57	21.15	22.35	25.7	20.5	22.1	26.7	22	20.5	25.3	20.2	40.4	44	45.4	49.4	26.3
FH28E-50S-0.5SH(05)	CL580-1815-7-05	50	24.5	29.9	25.57	26.15	27.35	30.7	25.5	27.1	31.7	27	25.5	30.3	20.2	40.4	44	45.4	49.4	31.3
FH28E-60S-0.5SH(05)	CL580-1834-1-05	60	29.5	34.9	30.57	31.15	32.35	35.7	30.5	32.1	36.7	32	30.5	35.3	26.2	52.4	56	57.4	61.4	36.3
FH28E-68S-0.5SH(05)	CL580-1841-7-05	68	33.5	38.9	34.57	35.15	36.35	39.7	34.5	36.1	40.7	36	34.5	39.3	26.2	52.4	56	57.4	61.4	40.3

⑨ : The specification of (07) is applied to FH28E-40S-0.5SH.

HRS	DRAWING NO.	EDC-156370-05-05
	PART NO.	FH28E-*S-0.5SH(05)
	CODE NO.	CL586
		④ 4/4