

Photoelectrics Diffuse-reflective Type PH18CND..., DC

CARLO GAVAZZI



- Miniature sensor range
- Range: 1 m
- Sensitivity adjustment by potentiometer
- Modulated, red light 625 nm
- Supply voltage: 10 to 30 VDC
- Output: 100 mA, NPN or PNP, N.O & N.C.
- Degree of protection IP67, IP69K
- LED indication for output, stability and power ON
- Protection: reverse polarity, short circuit and transients
- Cable, plug and pigtail versions
- Excellent EMC performance



Product Description

The PH18CND10... is part of a family of inexpensive general purpose diffuse reflective sensors in industrial standard 18 mm cylindrical and square ABS housing. The sensors are useful in applications where high-accuracy detection as well as small size is required.

Compact housing and high power LED for excellent performance-size ratio. The potentiometer used for adjustment of the sensitivity makes the sensors highly flexible. The output type is NPN or PNP and the output switching function is NO and NC.

Ordering Key

PH18CND10PAM1SA

Type	PH18CND10PAM1SA
Housing style square	PH18CND10PAM1SA
Housing size	PH18CND10PAM1SA
Housing material	PH18CND10PAM1SA
Housing type neutral	PH18CND10PAM1SA
Detection principle	PH18CND10PAM1SA
Sensing distance	PH18CND10PAM1SA
Output type	PH18CND10PAM1SA
Output configuration	PH18CND10PAM1SA
Connection type	PH18CND10PAM1SA
Sensitive adjustment	PH18CND10PAM1SA

Type Selection

Housing style	Range S _n	Connection	Ordering no. NPN Make & break switching	Ordering no. PNP Make & break switching
M18 Square type	1 m	Cable	PH 18 CND 10 NASA	PH 18 CND 10 PASA
M18 Square type	1 m	Plug	PH 18 CND 10 NAM1SA	PH 18 CND 10 PAM1SA
M18 Square type	1 m	Pigtail M12	PH 18 CND 10 NAT1SA	PH 18 CND 10 PAT1SA

Specifications according to EN60947-5-2

Rated operating distance (S_n)	Up to 1 m, reference target Kodak test card R27, white, 90% reflective, 200 x 200 mm	Voltage drop (U_d)	≤ 2.0 VDC @ 100 mA
Blind zone	2 mm @ S _n max.	Protection	Short-circuit, reverse polarity and transients
Sensitivity control	Adjustable by potentiometer	Light source	InGaAlP, LED, 625 nm
Electrical adjustment	210°	Light type	Red, modulated
Mechanical adjustment	240°	Sensing angle	± 2°
Adjustable distance	50-1000 mm	Ambient light	30.000 lux Incandescent lamp
Temperature drift	≤ 0.2%/°C	Light spot Diameter	Ø 30 mm @ 0.5 m
Hysteresis (H) (differential travel)	≤ 20%	Operating frequency	500 Hz
Rated operational volt. (U_B)	10 to 30 VDC (ripple included)	Response time	OFF-ON (t _{ON}) ≤ 1.0 ms ON-OFF (t _{OFF}) ≤ 1.0 ms
Ripple (U_{rpp})	≤ 10%	Power ON delay (t_v)	≤ 100 ms
Output current	Continuous (I _a) ≤ 100 mA Short-time (I) ≤ 100 mA (max. load capacity 100 nF)	Output function	Type: NPN or PNP Switching function: NO and NC
No load supply current (I_o)	≤ 25 mA @ 24 VDC	Indication	Output ON: LED, yellow Signal stability and power ON: LED, green
Minimum operational current (I_m)	0.5 mA		
OFF-state current (I_r)	≤ 100 µA		



Specifications (cont.)

Environment		Cable gland	POM, Black
Installation category	III (IEC 60664/60664A; 60947-1)	Trimmer shaft	POM, Dark Grey
Pollution degree	3 (IEC 60664/60664A; 60947-1)	Locknuts	PP, black
Degree of protection	IP 67, IP 69K*	Mounting bracket	PPA, black
Ambient temperature		Connection	
Operating	-25° to +60°C (-13° to +140°F)	Cable	PVC, grey, 2 m 4 x 0.25 mm ² , Ø = 4.5 mm M12, 4-pin (CONB14NF-series)
Storage	-40° to +70°C (-40° to +158°F)	Plug	PUR, grey, 30 cm 4 x 0.25 mm ² , Ø = 4.5 mm M12, 4-pin (CONB14NF-series)
Vibration	10 to 150 Hz, 1 mm/15 g (IEC 60068-2-6)	Pigtail	With cable: 85 g With pigtail: 40 g With plug: 25 g
Shock	30 g / 11ms, 3 pos, 3 neg per axis (IEC 60068-2-6, 60068-2-32)	Weight	Yes
Rated insulation voltage	500 VAC (rms) IEC protection class III	CE-marking	Yes
Housing material		Approvals	cULus (UL508) supply class 2
Body	ABS, grey		
Backpart	PC-Transparent		
Front material	PMMA, red		

* The IP69K test according to DIN 40050-9 for high-pressure, high-temperature wash-down applications. The sensor must not only be dust tight (IP6X), but also able to withstand high-pressure and steam cleaning. The sensor is exposed to high pressure water from a spray nozzle that is fed with 80°C water at 8'000–10'000 KPa (80–100bar) and a flow rate of 14–6L/min. The nozzle is held 100 –150 mm from the sensor at angles of 0°, 30°, 60° and 90° for 30s each. The test device sits on a turntable that rotates with a speed of 5 times per minute. The sensor must not suffer any damaging effects from the high pressure water in appearance and function.

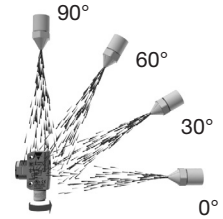

Operation Diagram

tv = Power ON delay

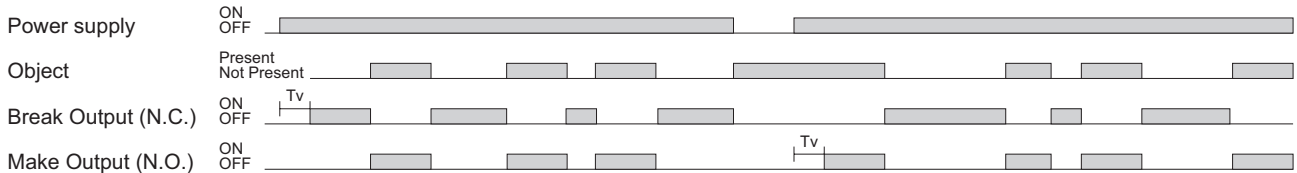

Wiring Diagrams

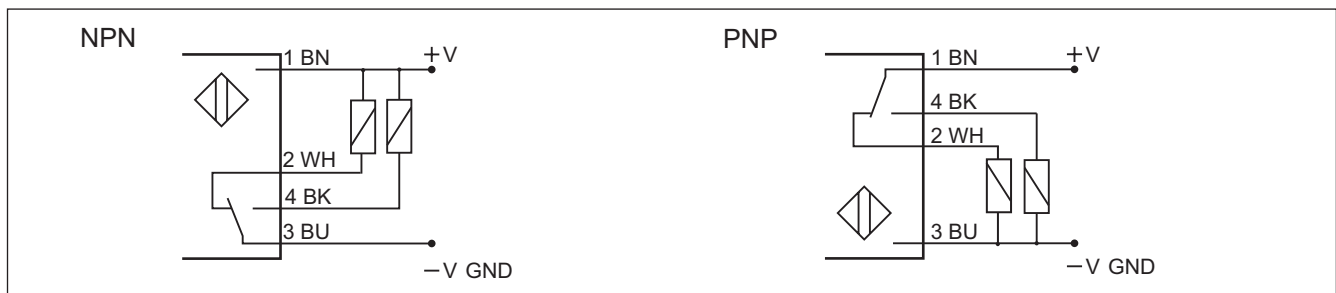

Detection Diagram

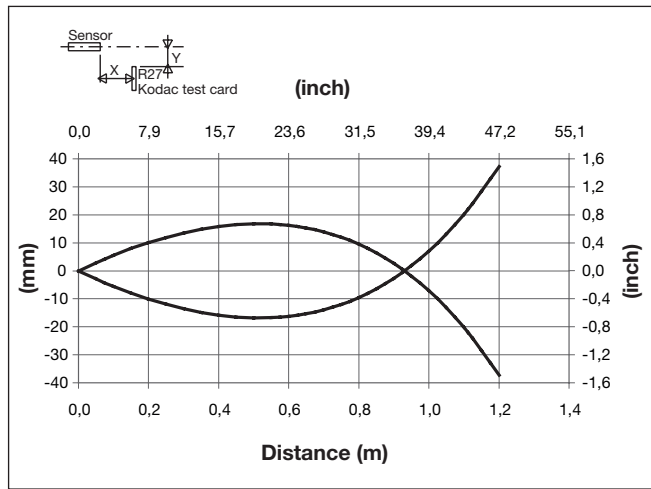

Excess Gain

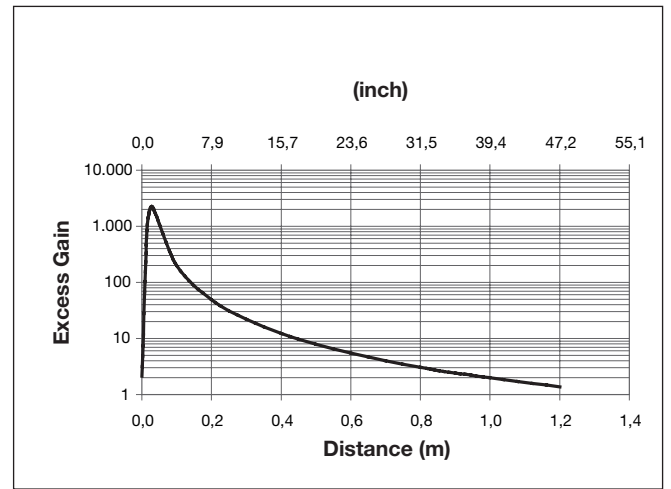

Signal Stability Indication

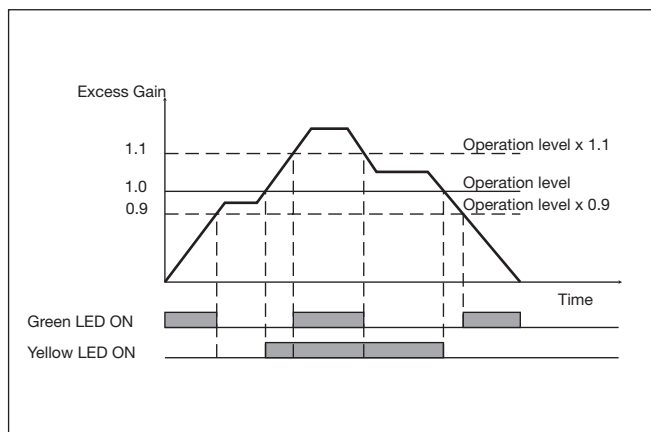

APH18-MB1

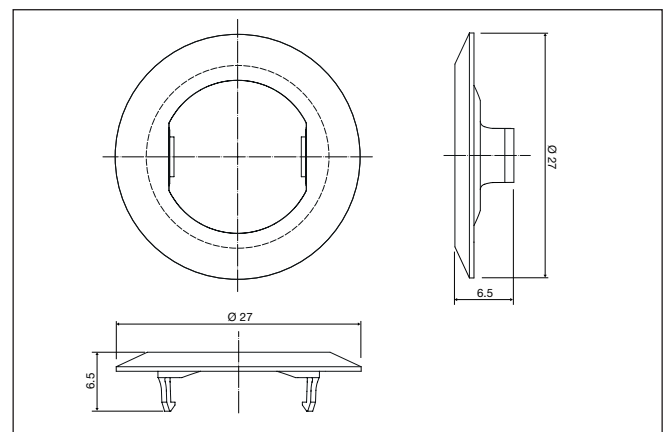

Mounting Systems

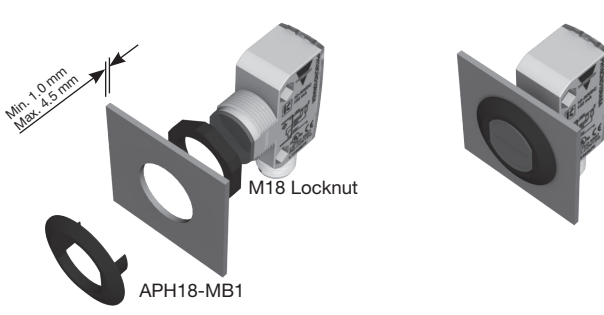

Min. 1.0 mm
Max. 4.5 mm

M18 Locknut

APH18-MB1

PH18 mounting with a combination of 1 x APH18-MB1 and 1 x M18 locknut.
Maximum torque 0.9 NM

Dimensions

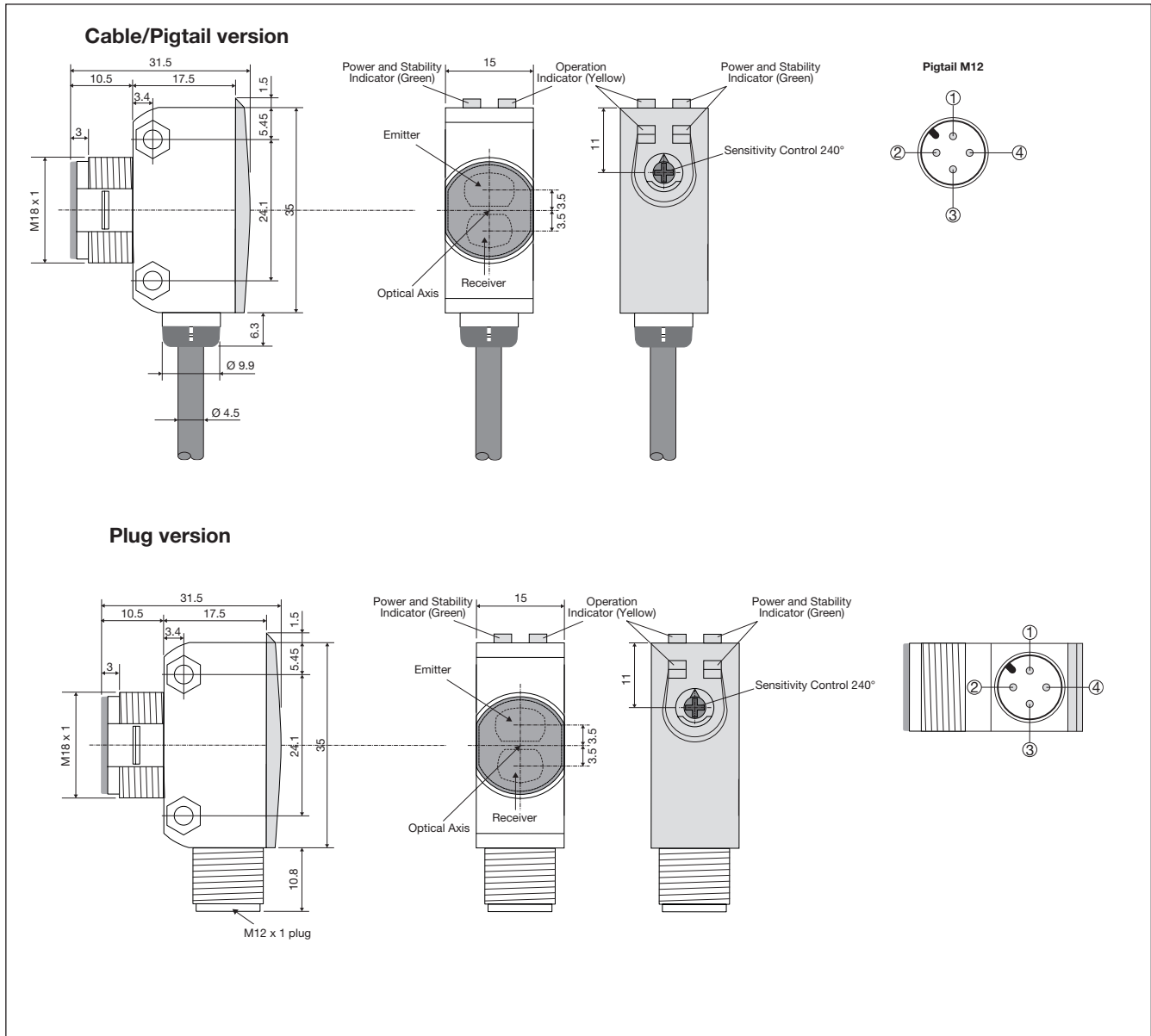

Installation Hints

To avoid interference from inductive voltage / current peaks, separate the proximity switch cables from any other power cables. E.g. Engine, contactor or solenoid cables

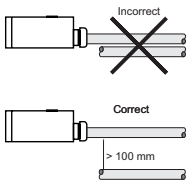

Relief of the cable strain

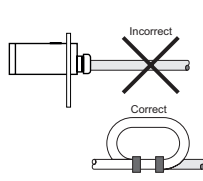

The cable should not be pulled

Protection of the sensing face

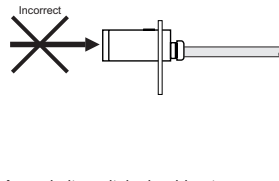

A proximity switch should not serve as mechanical stop

Sensor mounted on a mobile carrier

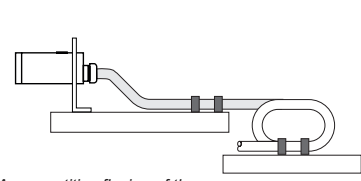

Any repetitive flexing of the cable should be avoided

Delivery Contents

- Photoelectric switch: PH 18 CND...
- Installation instruction on plastic bag
- Screwdriver
- Mounting bracket APH18-MB1
- 1 M18 locknuts
- **Packaging:** Plastic bag

Accessories

- Connector type CONG1A.. / CONB14NF.. series

Mouser Electronics

Authorized Distributor

Click to View Pricing, Inventory, Delivery & Lifecycle Information:

[Carlo Gavazzi:](#)

[PH18CND10NAM1SA](#) [PH18CND10NASA](#) [PH18CND10NAT1SA](#) [PH18CND10PAM1SA](#) [PH18CND10PASA](#)
[PH18CND10PAT1SA](#)