

LOC		DIST		REVISIONS			
AD	00	REV	DATE	BY	CHK	APPV	
E3		REVISED PER ECO-11-005033	28MAR11	RK	HMR		
F		ECR-12-010652	25NOV12	SY	AC		

### CONNECTOR ASSEMBLY EXAMPLARY LOADED

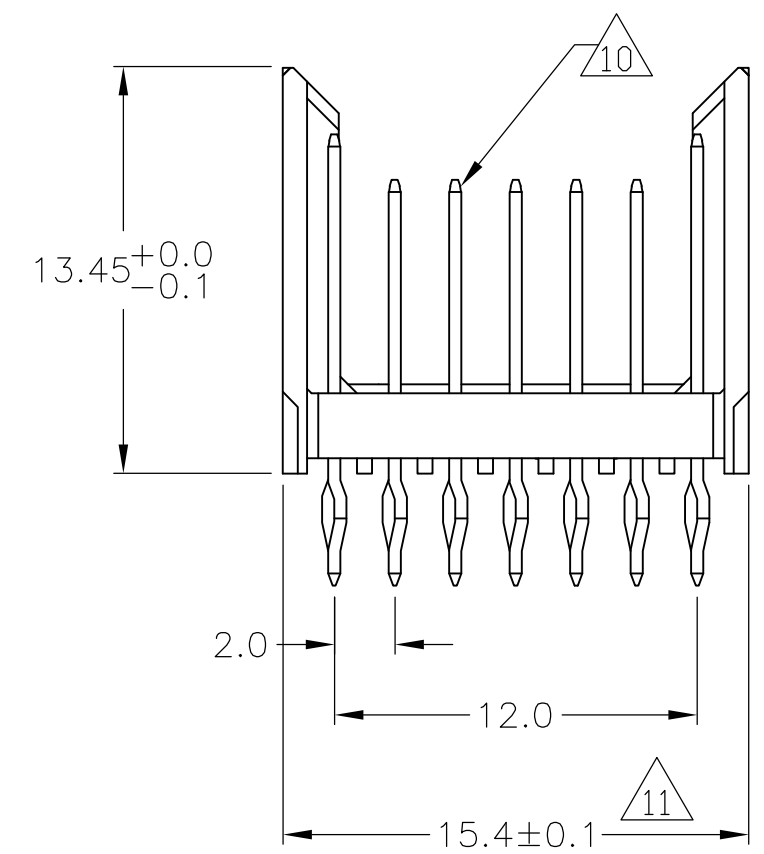
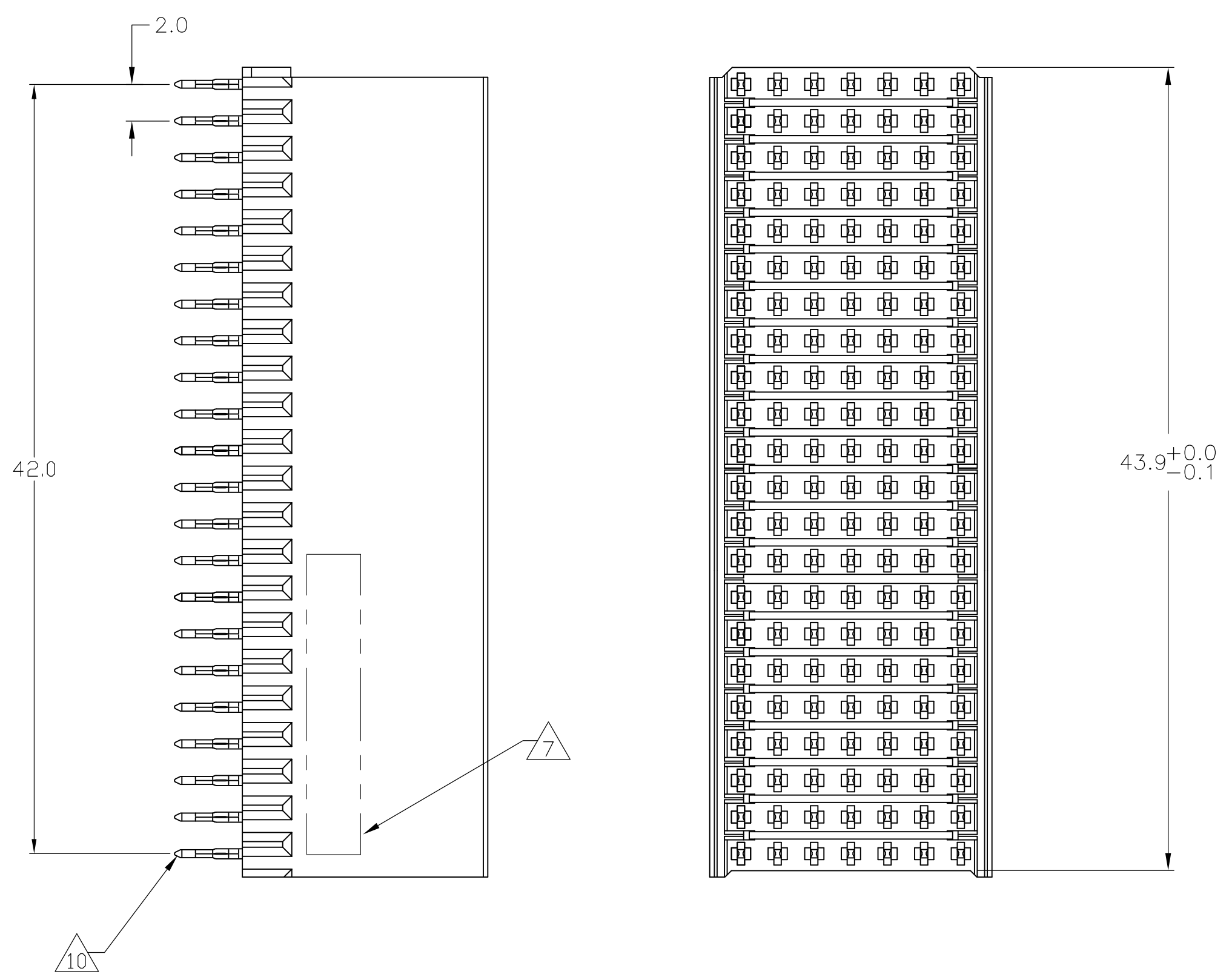

### CONTACT DIMENSIONS

SCALE 5:1

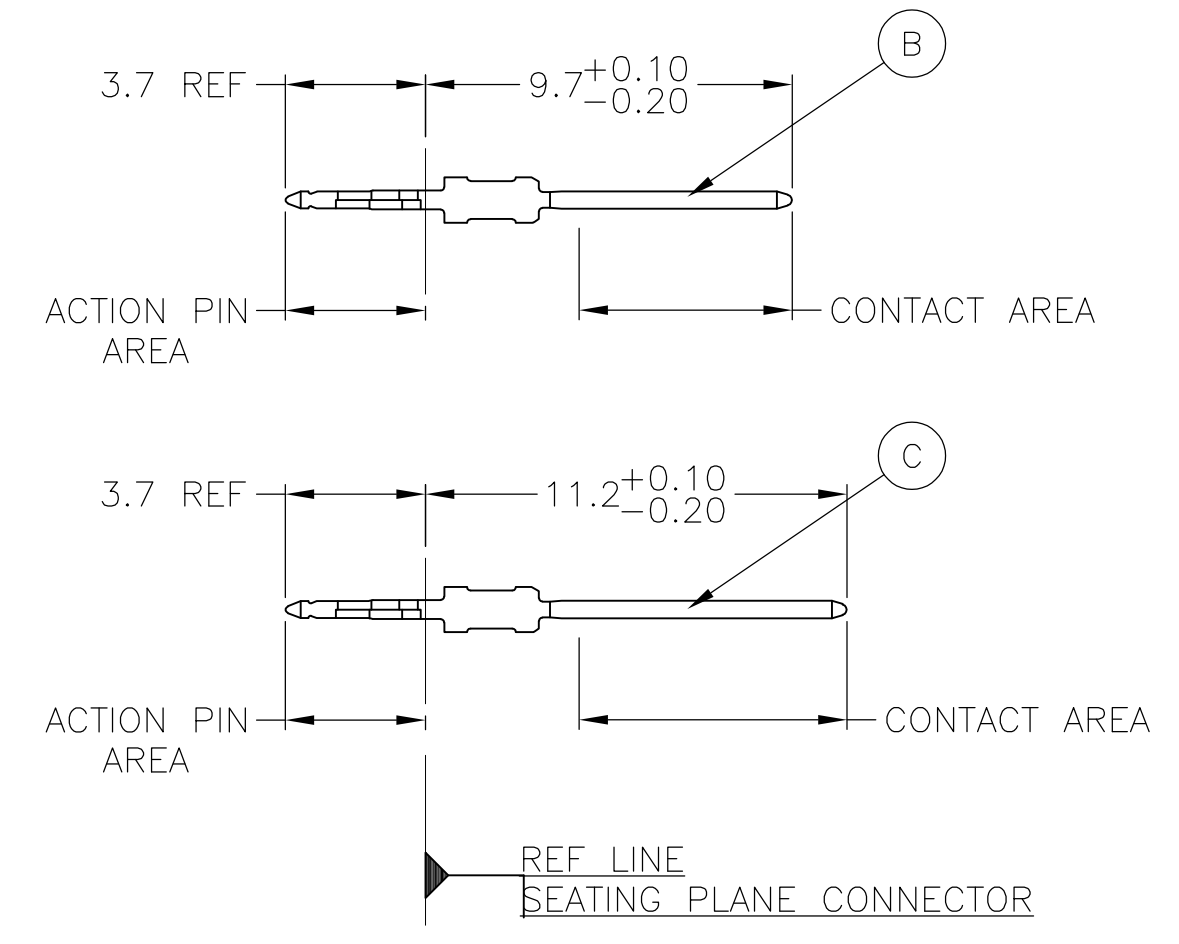

### CONTACT LAYOUT

	z	a	b	c	d	e	f
1	C	B	B	B	B	B	C
2	C	B	B	B	B	B	C
3	C	B	B	B	B	B	C
4	C	B	B	B	B	B	C
5	C	B	B	B	B	B	C
6	C	B	B	B	B	B	C
7	C	B	B	B	B	B	C
8	C	B	B	B	B	B	C
9	C	B	B	B	B	B	C
10	C	B	B	B	B	B	C
11	C	B	B	B	B	B	C
12	C	B	B	B	B	B	C
13	C	B	B	B	B	B	C
14	C	B	B	B	B	B	C
15	C	B	B	B	B	B	C
16	C	B	B	B	B	B	C
17	C	B	B	B	B	B	C
18	C	B	B	B	B	B	C
19	C	B	B	B	B	B	C
20	C	B	B	B	B	B	C
21	C	B	B	B	B	B	C
22	C	B	B	B	B	B	C

### RECOMMENDED PCB-HOLE LAYOUT COMPONENT SIDE SHOWN

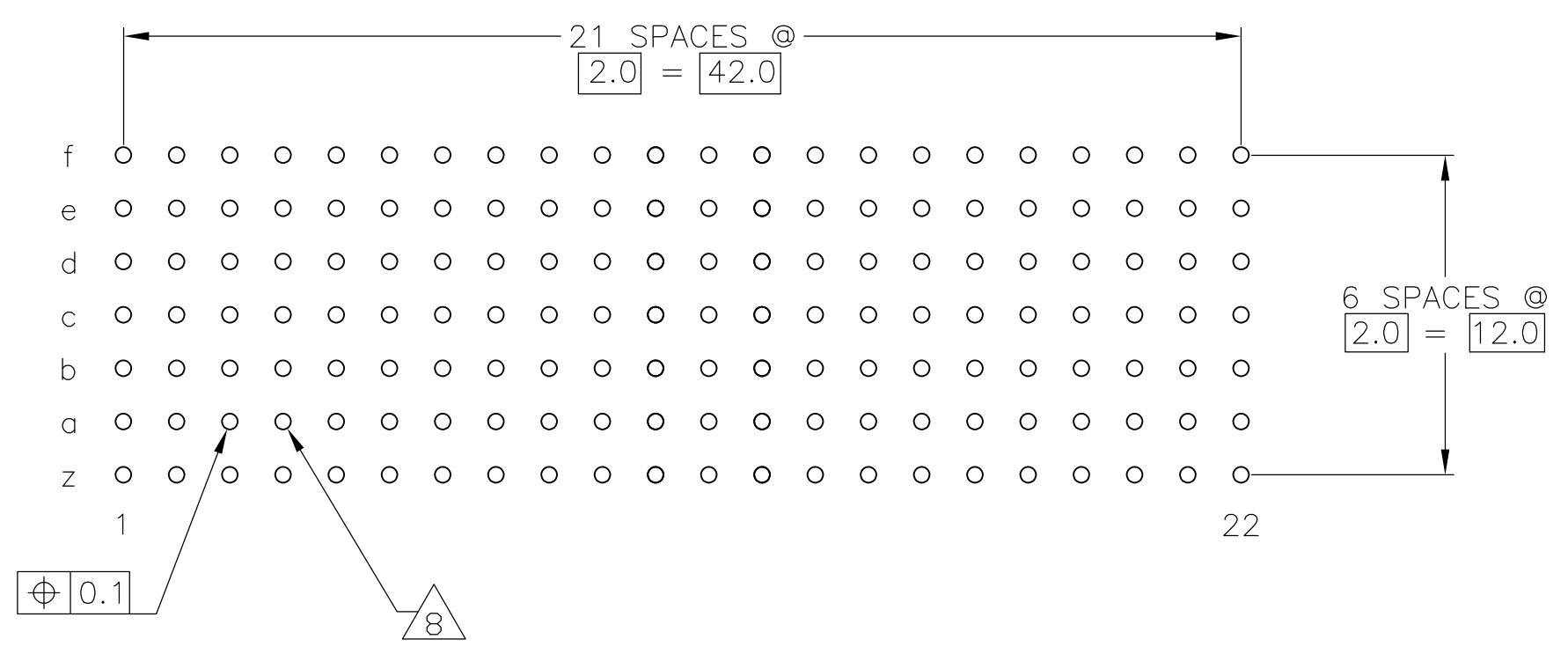

### PLATED THRU HOLES PARAMETERS

REFERENCE APPLICATION SPECIFICATION

	2 5 12 13	3-188835-1
	2 3 13	3-188835-0
	2 6 12	1-188835-9
OBSOLETE	2 5 12	<del>1-188835-9</del>
	2 4	188835-4
	2 3	188835-1
	FINISH	PART NUMBER

THIS DRAWING IS A CONTROLLED DOCUMENT.		DIN B CARBO 130DEC05		STE TE Connectivity	
DIMENSIONS: mm		TOLERANCES UNLESS OTHERWISE SPECIFIED:		NAME	
0.1		0.1		108-19082	
1		1		114-19029	
MATERIAL		FINISH		WEIGHT	
SEE TABLE		SEE TABLE		A1 00779 C=188835	
CUSTOMER DRAWING		SCALE 4:1		SHEET 1 OF 2 REV F	

THIS DRAWING IS UNPUBLISHED. RELEASED FOR PUBLICATION  
 © COPYRIGHT - By - ALL RIGHTS RESERVED.

LOC		DIST		REVISIONS				
AD	00	REV	LYR	DESCRIPTION	DATE	DMN	APVO	
-	-	-	-	SEE SHEET 1	-	-	-	

- 1 MATERIAL:  
CONTACT: PHOSPHOR BRONZE.  
HOUSING: GLASS-FILLED POLYESTER.
- 2 GENERAL PLATING SPECIFICATION: UNDERPLATING  
(ENTIRE CONTACT): 1.27µm MIN NICKEL AND ACTION  
PIN: 0.5µm MIN TIN LEAD.  
FOR PLATING OF MATING SURFACES SEE APPLICABLE  
SPECIFICATION REFERENCE FOR EACH DASH NUMBER.
- 3 CONFORMS TO ALL TESTING ACCORDING TO IEC 61076-4-101  
PERFORMANCE LEVEL 2.
- 4 CONFORMS TO ALL TESTING ACCORDING TO IEC 61076-4-101  
PERFORMANCE LEVEL 1.
- 5 CONNECTOR TESTED AND QUALIFIED AGAINST TELCORDIA GR-1217-CORE QUALITY LEVEL 3,  
CENTRAL OFFICE APPLICATIONS.
- 6 CONNECTOR TESTED AND QUALIFIED AGAINST TELCORDIA GR-1217-CORE QUALITY LEVEL 3,  
UNCONTROLLED ENVIROMENT APPLICATIONS.
- 7 CONNECTOR MARKED WITH PART NUMBER AND DATE CODE.  
ADDITIONAL CHARACTERS OR MARKINGS, AS WELL AS THE LOCATION OF THE MARKINGS,  
MAY BE ADDED FOR TRACEABILITY BASED UPON MANUFACTURERS DISCRETION.
- 8 PLATED-THROUGH HOLES AT 2x2mm SQUARE GRID  
PATTERN DEFINED BY CONTACT LAYOUT.
- 9 FOR ACTUAL PIN LOADING SEE "CONTACT LAYOUT".
- 10 FOR ACTUAL PIN DIMENSIONS SEE "CONTACT DIMENSIONS".
- 11 TO BE MEASURED AT BOTTOM OF SHROUD.
- 12 CONNECTOR LUBRICATED WITH BELCORE APPROVED LUBRICANT,  
TECHNICAL REFERENCE: TR-NWT-001217 ISSUE 1, SEP 1992.
- 13 0.76µm MIN GOLD PLATING AT MATING SURFACES.

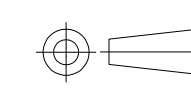
THIS DRAWING IS A CONTROLLED DOCUMENT.		DIN E CARBO 13DEC05	 TE Connectivity	
		CHK G SKIPPER 13DEC05		
		APVO G SKIPPER 13DEC05	NAME	
DIMENSIONS: mm		PRODUCT SPEC 108-19082		MALE ASSEMBLY, Z-PACK 2mm HM, TYPE B
 0 PLC ± - 1 PLC ± 0.1 2 PLC ± - 3 PLC ± - 4 PLC ± - ANGLES ± ± -		APPLICATION SPEC 114-19029		RESTRICTED TO
MATERIAL SEE SHEET 1	FINISH SEE SHEET 1	WEIGHT -	SIZE A1	CAGE CODE 00779
		DRAWING NO 188835		REV F
		CUSTOMER DRAWING		SCALE 4:1 SHEET 2 OF 2

# Mouser Electronics

Authorized Distributor

Click to View Pricing, Inventory, Delivery & Lifecycle Information:

[TE Connectivity:](#)

[188835-1](#)