

QJxx16xHx Series

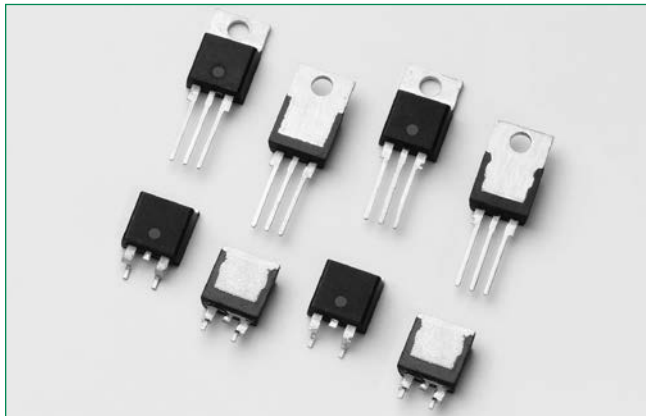

Agency Approval

Agency	Agency File Number
	E71639*

* - L Package only

Main Features

Symbol	Value	Unit
$I_{T(RMS)}$	16	A
V_{DRM}/V_{RRM}	400, 600, or 800	V
$I_{GT(Q1)}$	10 to 80	mA

Schematic Symbol

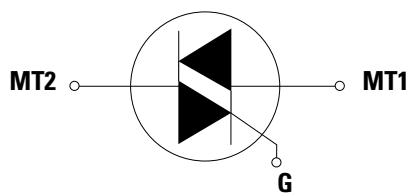

Description

This 16A high temperature Alternistor TRIAC, offered in TO-220AB, TO-220 isolated and TO-263 package, has 150°C maximum junction temperature and 200A I_{TSM} (60Hz). This series enables easier thermal management and higher surge handling capability in AC power control applications such as heater control, motor speed control, lighting controls, and static switching relays. Alternistor TRIAC operates in quadrants I, II, & III and offers high performance in applications requiring high commutation capability.

Features & Benefits

- High T_j of 150°C
- Voltage capability up to 600V
- Surge capability of 200A at 60Hz half cycle
- Mechanically and thermally robust TO-220 and TO-218 clip-attach assembly
- Internally-isolated TO-220 and TO-218 packages
- Halogen free and RoHS compliant
- Recognized to UL 1557 as an Electrically Isolated Semiconductor Devices

Applications

TRIAC is an excellent AC switch in applications such as heating, lighting, and motor speed controls.

Typical applications are

- Heater control such as coffee brewer, tankless water heater and infrared heater
- AC solid-state relays
- Light dimmers including incandescent and LED lighting
- Motor speed control in kitchen appliances, power tools, home/brow/white goods and light industrial applications as compressor motor control

Alternistor TRIAC is used with high inductive loads requiring the high commutation capability. Internally isolated packages offer better heat sinking with higher isolation voltage.

Absolute Maximum Ratings – Alternistor Triac (3 Quadrants)

Symbol	Parameter	Value	Unit		
$I_{T(RMS)}$	RMS on-state current (full sine wave)	QJxx16LHy $T_C = 115^\circ\text{C}$	16	A	
		QJxx16RHx QJxx16NHx $T_C = 130^\circ\text{C}$			
I_{TSM}	Non repetitive surge peak on-state current (Single half cycle, T_J initial = 25°C)	f = 50Hz t = 20 ms	167	A	
		f = 60Hz t = 16.7 ms	200		
I^2t	I^2t Value for fusing	$t_p = 8.3$ ms	166	A^2s	
di/dt	Critical rate of rise of on-state current	f = 60Hz $T_J = 150^\circ\text{C}$	100	A/ μs	
I_{GTM}	Peak gate trigger current	$t_p \leq 10\mu\text{s};$ $I_{GT} \leq I_{GTM}$ $T_J = 150^\circ\text{C}$	2.0	A	
$P_{G(AV)}$	Average gate power dissipation	$T_J = 150^\circ\text{C}$	0.5	W	
T_{stg}	Storage temperature range		-40 to 150	$^\circ\text{C}$	
T_J	Operating junction temperature range		-40 to 150	$^\circ\text{C}$	
V_{DSM}/V_{RSM}	Peak non-repetitive blocking voltage	Pulse Width = 100 μs	600V	$V_{DRM}/V_{RRM} + 100$	V
V_{DSM}/V_{RSM}	Peak non-repetitive blocking voltage	Pulse Width = 100 μs	800V	$V_{DRM}/V_{RRM} + 200$	V

xx = voltage/10, y = sensitivity

Electrical Characteristics ($T_J = 25^\circ\text{C}$, unless otherwise specified) – Alternistor Triac (3 Quadrants)

Symbol	Test Condition	Quadrant	QJxx16xH2	QJxx16xH3	QJxx16xH4	QJxx16xH5	QJxx16xH6	Unit	
I_{GT}	$V_D = 12\text{V}$ $R_L = 60\Omega$	I-II-III	MAX.	10	20	35	50	80	mA
V_{GT}		I-II-III	MAX.	1.3					V
V_{GD}	$V_D = V_{DRM}$ $R_L = 3.3\text{k}\Omega$ $T_J = 150^\circ\text{C}$	I-II-III	MIN.	0.15					V
I_H	$I_T = 100\text{mA}$		MAX.	15	35	50	50	70	mA
dv/dt	$V_D = V_{DRM}$ Gate Open $T_J = 150^\circ\text{C}$	600V	MIN.	-	250	350	-	850	V/ μs
		800V		-	-	400	600	-	
	$V_D = 2/3V_{DRM}$ Gate Open $T_J = 150^\circ\text{C}$	600V	MIN.	50	300	400	-	925	
		800V		-	600	700	800	-	
(dv/dt)c	(di/dt)c = 8.6A/ms $T_J = 150^\circ\text{C}$		MIN.	2	20	25	30	30	V/ μs
t_{gt}	$I_G = 2X I_{GT}$ PW = 15s $I_T = 22.6\text{A(pk)}$		TYP.	3	3	3	5	5	μs

Static Characteristics

Symbol	Test Conditions	Value	Unit		
V_{TM}	$I_T = 22.6\text{A}$ $t_p = 380\mu\text{s}$	MAX	1.60	V	
I_{DRM}/I_{RRM}	@ V_{DRM}/V_{RRM}	$T_J = 25^\circ\text{C}$	MAX	5	μA
		$T_J = 150^\circ\text{C}$	MAX	4	mA

Thermal Resistances

Symbol	Parameter	Value	Unit	
$R_{\theta(J-C)}$	Junction to case (AC)	QJxx16RHx QJxx16NHx	0.90	$^\circ\text{C/W}$
		QJxx16LHy	1.8	
$R_{\theta(J-A)}$	Junction to ambient	QJxx16RHx QJxx16NHx	45	$^\circ\text{C/W}$
		QJxx16LHy	50	

xx = voltage/10, y = sensitivity

Figure 1: Definition of Quadrants

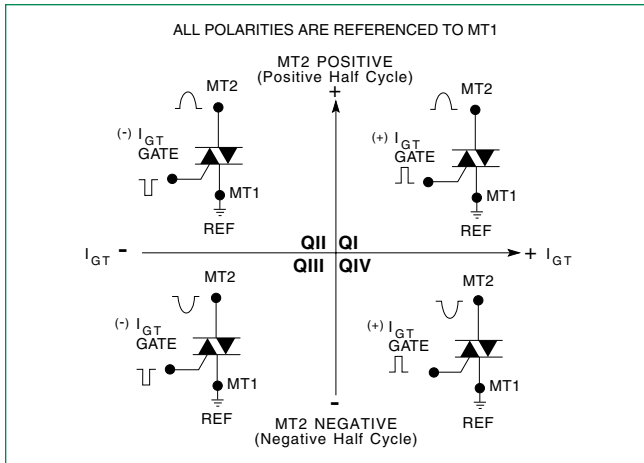

Note: Alternistors will not operate in QIV

Figure 2: Normalized DC gate trigger current for Quadrants I, II, and III vs Junction Temperature

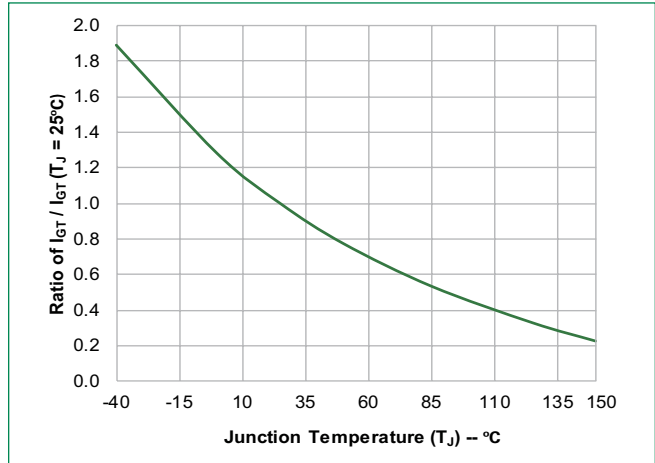

Figure 3: Normalized DC Holding Current vs. Junction Temperature

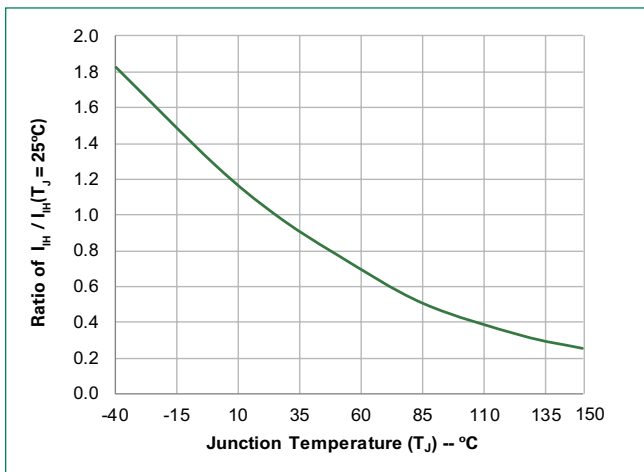

Figure 4: Normalized DC gate trigger current for Quadrants I, II, and III vs Junction Temperature

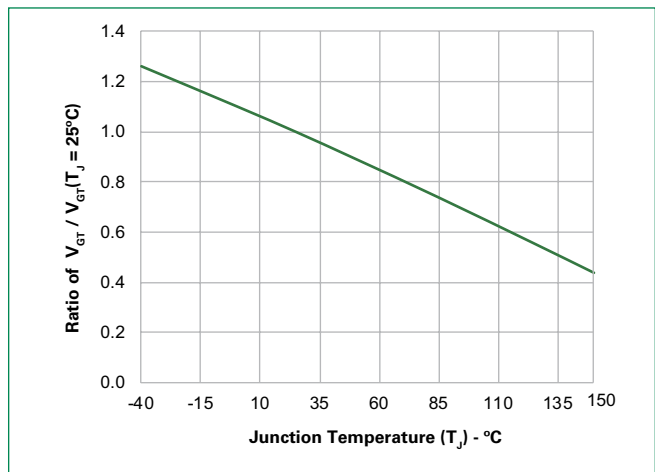

Figure 5: Power Dissipation (Typical) vs. RMS On-State Current

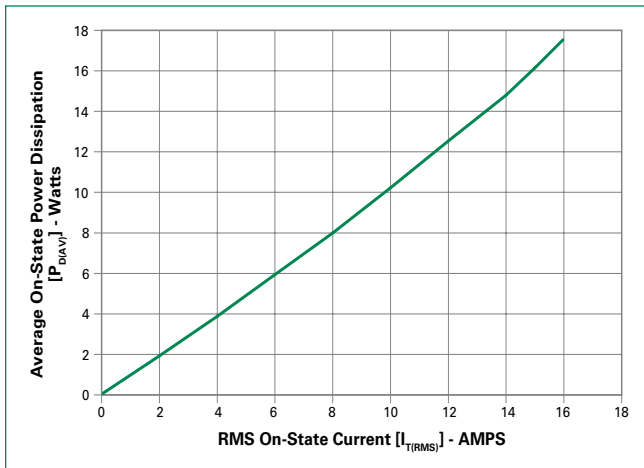

Figure 6: On-State Current vs. On-State Voltage (Typical)

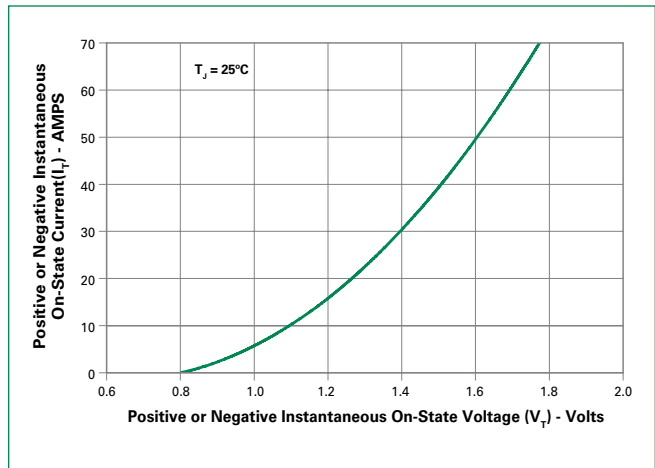

Figure 7: Maximum Allowable Case Temperature vs. RMS On-State Current

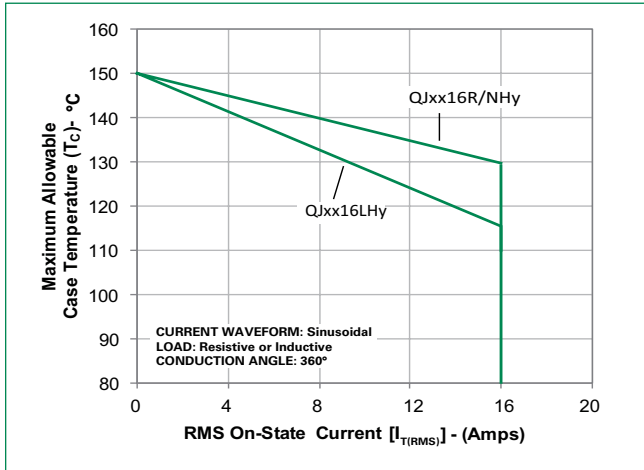
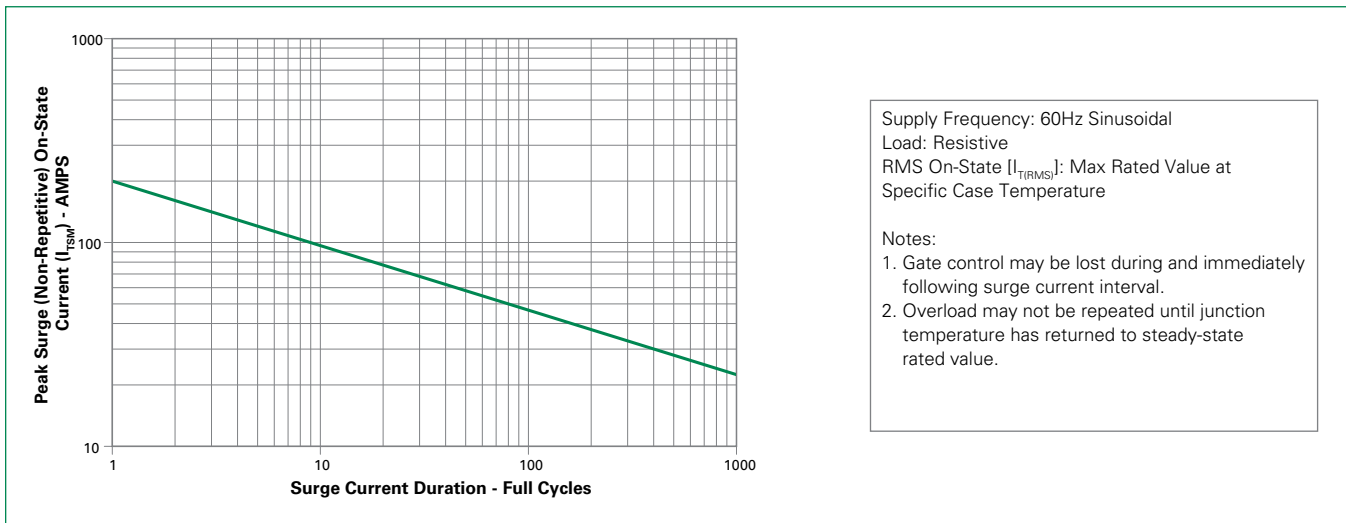
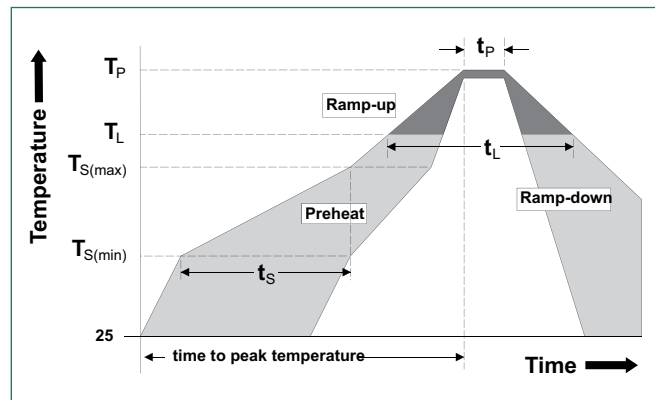

Figure 8: Surge Peak On-State Current vs. Number of Cycles



Soldering Parameters

Reflow Condition		Pb – Free assembly
Pre Heat	- Temperature Min ($T_{s(min)}$)	150°C
	- Temperature Max ($T_{s(max)}$)	200°C
	- Time (min to max) (t_s)	60 – 180 secs
Average ramp up rate (Liquidus Temp) (T_L) to peak		5°C/second max
$T_{S(max)}$ to T_L - Ramp-up Rate		5°C/second max
Reflow	- Temperature (T_L) (Liquidus)	217°C
	- Time (t_L)	60 – 150 seconds
Peak Temperature (T_p)		260 ^{+0/-5} °C
Time within 5°C of actual peak Temperature (t_p)		20 – 40 seconds
Ramp-down Rate		5°C/second max
Time 25°C to peak Temperature (T_p)		8 minutes Max.
Do not exceed		280°C



Physical Specifications

Terminal Finish	100% Matte Tin-plated
Body Material	UL Recognized compound meeting flammability rating V-0
Terminal Material	Copper Alloy

Design Considerations

Careful selection of the correct component for the application's operating parameters and environment will go a long way toward extending the operating life of the Thyristor. Good design practice should limit the maximum continuous current through the main terminals to 75% of the component rating. Other ways to ensure long life for a power discrete semiconductor are proper heat sinking and selection of voltage ratings for worst case conditions. Overheating, overvoltage (including dv/dt), and surge currents are the main killers of semiconductors. Correct mounting, soldering, and forming of the leads also help protect against component damage.

Environmental Specifications

Test	Specifications and Conditions
AC Blocking	MIL-STD-750, M-1040, Cond A Applied Peak AC voltage @ 150°C for 1008 hours
Temperature Cycling	MIL-STD-750, M-1051, 100 cycles; -40°C to +150°C; 15-min dwell time
Temperature/Humidity	EIA / JEDEC, JESD22-A101 1008 hours; 160V - DC: 85°C; 85% rel humidity
High Temp Storage	MIL-STD-750, M-1031, 1008 hours; 150°C
Low-Temp Storage	1008 hours; -40°C
Resistance to Solder Heat	MIL-STD-750 Method 2031
Solderability	ANSI/J-STD-002, category 3, Test A
Lead Bend	MIL-STD-750, M-2036 Cond E
Moisture Sensitivity Level	Level 1, JEDEC-J-STD-020

Dimensions – TO-220AB (R-Package) – Non-Isolated Mounting Tab Common with Center Lead

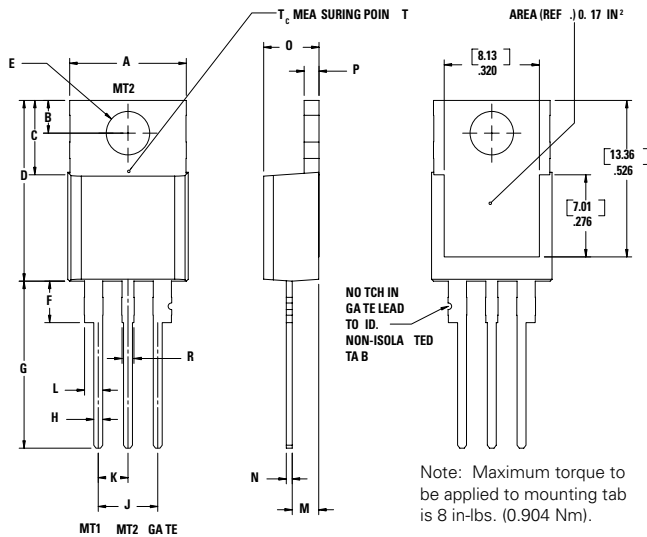

Dimension	Inches		Millimeters	
	Min	Max	Min	Max
A	0.380	0.420	9.65	10.67
B	0.105	0.115	2.66	2.92
C	0.230	0.250	5.84	6.35
D	0.590	0.620	14.99	15.75
E	0.142	0.147	3.61	3.73
F	0.110	0.130	2.79	3.30
G	0.540	0.575	13.72	14.61
H	0.025	0.035	0.64	0.89
J	0.195	0.205	4.95	5.21
K	0.095	0.105	2.41	2.67
L	0.060	0.075	1.52	1.91
M	0.085	0.095	2.16	2.41
N	0.018	0.024	0.46	0.61
O	0.178	0.188	4.52	4.78
P	0.045	0.060	1.14	1.52
R	0.038	0.048	0.97	1.22

Dimensions – TO-220AB (L-Package) – Isolated Mounting Tab

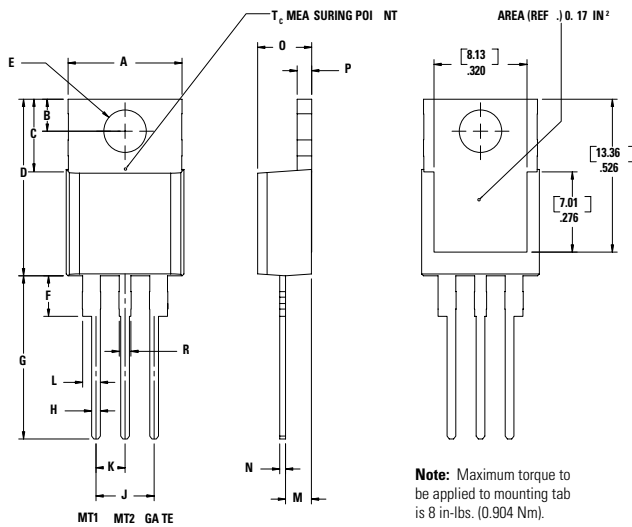

Dimension	Inches		Millimeters	
	Min	Max	Min	Max
A	0.380	0.420	9.65	10.67
B	0.105	0.115	2.67	2.92
C	0.230	0.250	5.84	6.35
D	0.590	0.620	14.99	15.75
E	0.142	0.147	3.61	3.73
F	0.110	0.130	2.79	3.30
G	0.540	0.575	13.72	14.60
H	0.025	0.035	0.64	0.89
J	0.195	0.205	4.95	5.21
K	0.095	0.105	2.41	2.67
L	0.060	0.075	1.52	1.91
M	0.085	0.095	2.16	2.41
N	0.018	0.024	0.46	0.61
O	0.178	0.188	4.52	4.78
P	0.045	0.060	1.14	1.52
R	0.038	0.048	0.97	1.22

Dimensions – TO-263AB (N-Package) – D²Pak Surface Mount

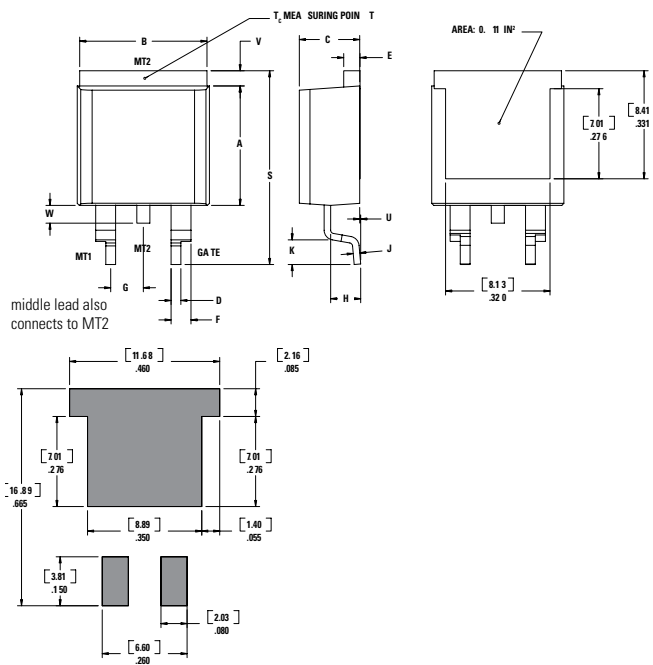

Dimension	Inches		Millimeters	
	Min	Max	Min	Max
A	0.360	0.370	9.14	9.40
B	0.380	0.420	9.65	10.67
C	0.178	0.188	4.52	4.78
D	0.025	0.035	0.64	0.89
E	0.045	0.060	1.14	1.52
F	0.060	0.075	1.52	1.91
G	0.095	0.105	2.41	2.67
H	0.092	0.102	2.34	2.59
J	0.018	0.024	0.46	0.61
K	0.090	0.110	2.29	2.79
S	0.590	0.625	14.99	15.88
V	0.035	0.045	0.89	1.14
U	0.002	0.010	0.05	0.25
W	0.040	0.070	1.02	1.78

Product Selector

Part Number	Voltage			Gate Sensitivity Quadrants	Type	Package
	400V	600V	800V	I – II – III		
QJxx16LH2	X	X	-	10 mA	Alternistor Triac	TO-220L
QJxx16RH2	X	X	-	10 mA	Alternistor Triac	TO-220R
QJxx16NH2	X	X	-	10 mA	Alternistor Triac	TO-263 D ² -PAK
QJxx16LH3	X	X	X	20 mA	Alternistor Triac	TO-220L
QJxx16RH3	X	X	X	20 mA	Alternistor Triac	TO-220R
QJxx16NH3	X	X	X	20 mA	Alternistor Triac	TO-263 D ² -PAK
QJxx16LH4	X	X	X	35 mA	Alternistor Triac	TO-220L
QJxx16RH4	X	X	X	35 mA	Alternistor Triac	TO-220R
QJxx16NH4	X	X	X	35 mA	Alternistor Triac	TO-263 D ² -PAK
QJxx16LH6	X	X	-	80 mA	Alternistor Triac	TO-220L
QJxx16RH6	X	X	-	80 mA	Alternistor Triac	TO-220R
QJxx16NH6	X	X	-	80 mA	Alternistor Triac	TO-263 D ² -PAK
QJxx16LH5	-	-	X	50 mA	Alternistor Triac	TO-220L
QJxx16RH5	-	-	X	50 mA	Alternistor Triac	TO-220R
QJxx16NH5	-	-	X	50 mA	Alternistor Triac	TO-263 D ² -PAK

Packing Options

Part Number	Marking	Weight	Packing Mode	Base Quantity
QJxx16L/RHyTP	QJxx16L/RHy	2.2 g	Tube Pack	500 (50 per tube)
QJxx16NHyTP	QJxx16NHy	1.6 g	Tube Pack	500 (50 per tube)
QJxx16NHyRP	QJxx16NHy	1.6 g	Embossed Carrier	500

xx = voltage/10; y = Sensitivity

Part Numbering System

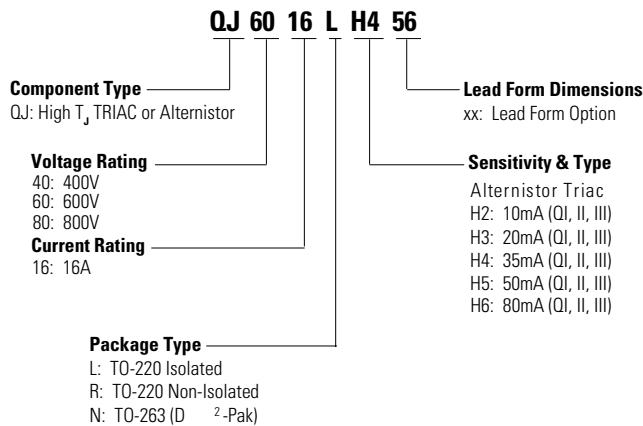

Part Marking System

TO-220 AB - (L and R Package)
TO-263 AB - (N Package)

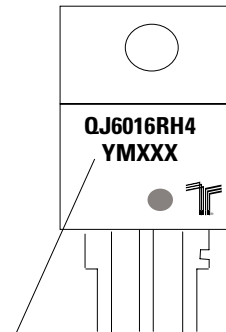

Date Code Marking
Y: Year Code
M: Month Code
XXX: Lot Trace Code

TO-263 Embossed Carrier Reel Pack (RP)

Meets all EIA-481-2 Standards

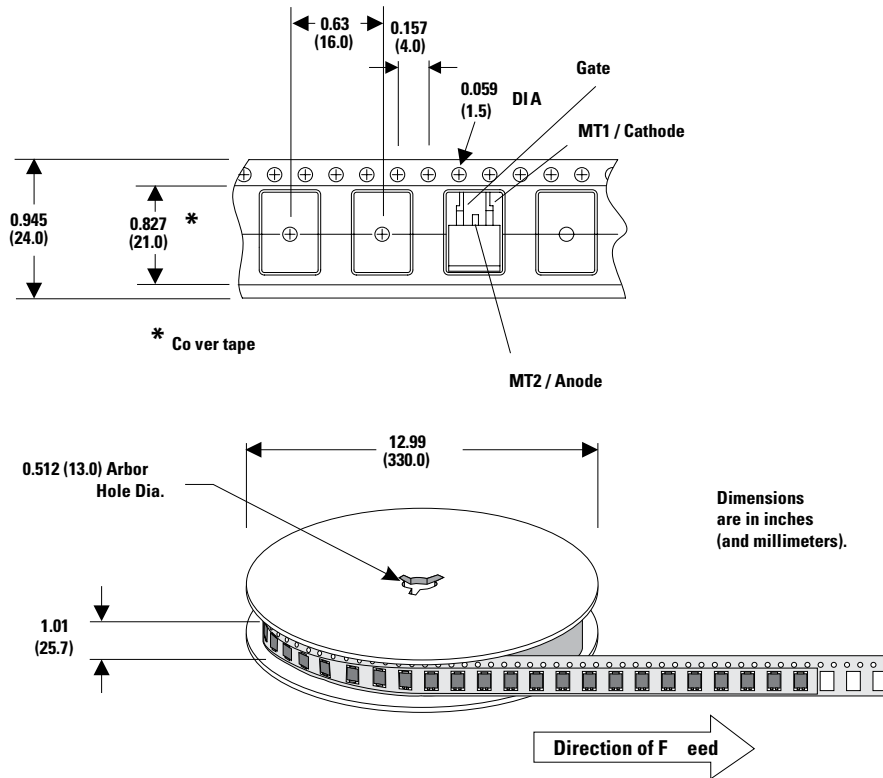

Mouser Electronics

Authorized Distributor

Click to View Pricing, Inventory, Delivery & Lifecycle Information:

Littelfuse:

[QJ6016NH4RP](#) [QJ4016LH6TP](#) [QJ6016LH2TP](#) [QJ6016LH6TP](#) [QJ6016NH2RP](#) [QJ4016RH4TP](#) [QJ4016RH3TP](#)
[QJ4016NH3RP](#) [QJ4016LH3TP](#) [QJ6016RH2TP](#) [QJ4016NH2RP](#) [QJ6016RH6TP](#) [QJ6016RH3TP](#) [QJ4016RH2TP](#)
[QJ4016NH6RP](#) [QJ6016LH4TP](#) [QJ4016LH4TP](#) [QJ6016NH3RP](#) [QJ4016NH4RP](#) [QJ6016RH4TP](#) [QJ6016LH3TP](#)
[QJ4016RH6TP](#) [QJ6016NH6RP](#) [QJ4016LH2TP](#) [QJ8016LH3TP](#) [QJ8016LH4TP](#) [QJ8016LH5TP](#) [QJ8016NH3RP](#)
[QJ8016NH4RP](#) [QJ8016NH5RP](#) [QJ8016RH3TP](#) [QJ8016RH4TP](#) [QJ8016RH5TP](#)