

## STEREO DIGITAL AMPLIFIER POWER STAGE

### FEATURES

- 2×100 W at 10% THD+N Into 4-Ω BTL <sup>(1)</sup>
- 2×80 W at 10% THD+N Into 6-Ω BTL
- 2×65 W at 10% THD+N Into 8-Ω BTL
- 4×40 W at 10% THD+N Into 3-Ω SE
- 4×30 W at 10% THD+N Into 4-Ω SE
- 1×160 W at 10% THD+N Into 3-Ω PBTL
- 1×200 W at 10% THD+N Into 2-Ω PBTL <sup>(1)</sup>
- >100 dB SNR (A-Weighted)
- <0.1% THD+N at 1 W
- Two Thermally Enhanced Package Options:
  - DKD (36-pin PSOP3)
  - DDV (44-pin HTSSOP)
- High-Efficiency Power Stage (>90%) With 140-mΩ Output MOSFETs
- Power-On Reset for Protection on Power Up Without Any Power-Supply Sequencing
- Integrated Self-Protection Circuits Including Undervoltage, Overtemperature, Overload, Short Circuit
- Error Reporting
- EMI Compliant When Used With Recommended System Design
- Intelligent Gate Drive

### APPLICATIONS

- Mini/Micro Audio System
- DVD Receiver
- Home Theater

### DESCRIPTION

The TAS5142 is a third-generation, high-performance, integrated stereo digital amplifier power stage with an improved protection system. The TAS5142 is capable of driving a 4-Ω bridge-tied load (BTL) at up to 100 W per channel with low integrated noise at the output, low THD+N performance, and low idle power dissipation.

A low-cost, high-fidelity audio system can be built using a TI chipset, comprising a modulator (e.g., TAS5508) and the TAS5142. This system only

requires a simple passive LC demodulation filter to deliver high-quality, high-efficiency audio amplification with proven EMI compliance. This device requires two power supplies, at 12 V for GVDD and VDD, and at 32 V for PVDD. The TAS5142 does not require power-up sequencing due to internal power-on reset. The efficiency of this digital amplifier is greater than 90% into 6 Ω, which enables the use of smaller power supplies and heatsinks.

The TAS5142 has an innovative protection system integrated on-chip, safeguarding the device against a wide range of fault conditions that could damage the system. These safeguards are short-circuit protection, overcurrent protection, undervoltage protection, and overtemperature protection. The TAS5142 has a new proprietary current-limiting circuit that reduces the possibility of device shutdown during high-level music transients. A new programmable overcurrent detector allows the use of lower-cost inductors in the demodulation output filter.

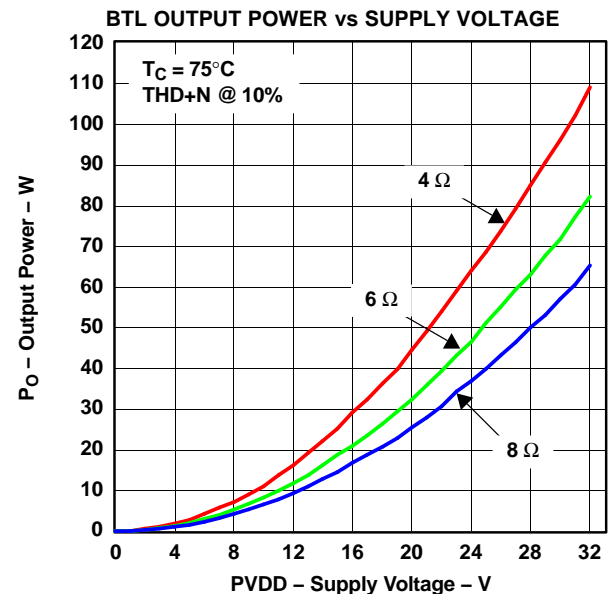

- (1) It is not recommended to drive 200 W (total power) into the DDV package continuously. For multichannel systems that require two channels to be driven at full power with the DDV package option, it is recommended to design the system so that the two channels are in two separate devices.



Please be aware that an important notice concerning availability, standard warranty, and use in critical applications of Texas Instruments semiconductor products and disclaimers thereto appears at the end of this data sheet.

PurePath Digital, PowerPad are trademarks of Texas Instruments.  
All trademarks are the property of their respective owners.



These devices have limited built-in ESD protection. The leads should be shorted together or the device placed in conductive foam during storage or handling to prevent electrostatic damage to the MOS gates.

### GENERAL INFORMATION

#### Terminal Assignment

The TAS5142 is available in two thermally enhanced packages:

- 36-pin PSOP3 package (DKD)
- 44-pin HTSSOP PowerPad™ package (DDV)

Both package types contain a heat slug that is located on the top side of the device for convenient thermal coupling to the heatsink.

DKD PACKAGE  
(TOP VIEW)

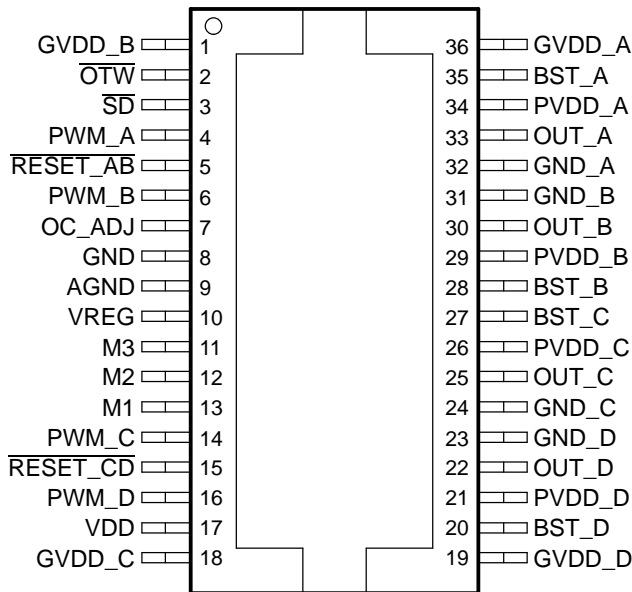

P0018-01

DDV PACKAGE  
(TOP VIEW)

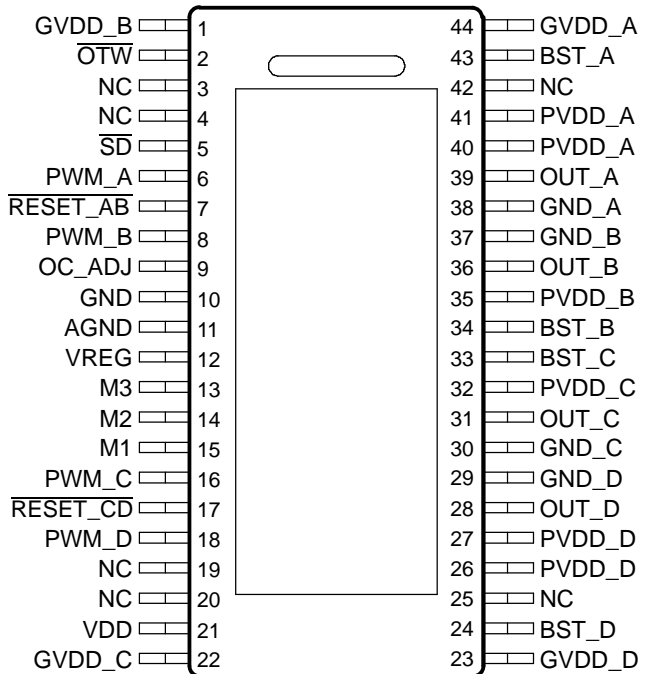

P0016-02

**GENERAL INFORMATION (continued)**

**MODE Selection Pins for Both Packages**

MODE PINS			PWM INPUT	OUTPUT CONFIGURATION	PROTECTION SCHEME
M3	M2	M1			
0	0	0	2N <sup>(1)</sup> AD/BD modulation	2 channels BTL output	BTL mode <sup>(2)</sup>
0	0	1	Reserved		
0	1	0	1N <sup>(1)</sup> AD modulation	2 channels BTL output	BTL mode <sup>(2)</sup>
0	1	1	1N <sup>(1)</sup> AD modulation	1 channel PBTL output	PBTL mode. Only PWM_A input is used.
1	0	0	1N <sup>(1)</sup> AD modulation	4 channels SE output	Protection works similarly to BTL mode <sup>(2)</sup> . Only difference in SE mode is that OUT_X is Hi-Z instead of a pulldown through internal pulldown resistor.
1	0	1	Reserved		
1	1	0			
1	1	1			

- (1) The 1N and 2N naming convention is used to indicate the required number of PWM lines to the power stage per channel in a specific mode.
- (2) An overload protection (OLP) occurring on A or B causes both channels to shut down. An OLP on C or D works similarly. Global errors like overtemperature error (OTE), undervoltage protection (UVP), and power-on reset (POR) affect all channels.

**Package Heat Dissipation Ratings<sup>(1)</sup>**

PARAMETER	TAS5142DKD	TAS5142DDV
R <sub>θJC</sub> (°C/W)—2 BTL or 4 SE channels (8 transistors)	1.28	1.28
R <sub>θJC</sub> (°C/W)—1 BTL or 2 SE channel(s) (4 transistors)	2.56	2.56
R <sub>θJC</sub> (°C/W)—(1 transistor)	8.6	8.6
Pad area <sup>(2)</sup>	80 mm <sup>2</sup>	36 mm <sup>2</sup>

- (1) JC is junction-to-case, CH is case-to-heatsink.
- (2) R<sub>θCH</sub> is an important consideration. Assume a 2-mil thickness of typical thermal grease between the pad area and the heatsink. The R<sub>θCH</sub> with this condition is 0.8°C/W for the DKD package and 1.8°C/W for the DDV package.

**ABSOLUTE MAXIMUM RATINGS**over operating free-air temperature range unless otherwise noted <sup>(1)</sup>

TAS5142	
VDD to AGND	–0.3 V to 13.2 V
GVDD_X to AGND	–0.3 V to 13.2 V
PVDD_X to GND_X <sup>(2)</sup>	–0.3 V to 50 V
OUT_X to GND_X <sup>(2)</sup>	–0.3 V to 50 V
BST_X to GND_X <sup>(2)</sup>	–0.3 V to 63.2 V
VREG to AGND	–0.3 V to 4.2 V
GND_X to GND	–0.3 V to 0.3 V
GND_X to AGND	–0.3 V to 0.3 V
GND to AGND	–0.3 V to 0.3 V
PWM_X, OC_ADJ, M1, M2, M3 to AGND	–0.3 V to 4.2 V
RESET_X, SD, OTW to AGND	–0.3 V to 7 V
Maximum continuous sink current (SD, OTW)	9 mA
Maximum operating junction temperature range, T <sub>J</sub>	0°C to 125°C
Storage temperature	–40°C to 125°C
Lead temperature, 1,6 mm (1/16 inch) from case for 10 seconds	260°C
Minimum pulse duration, low	50 ns

- (1) Stresses beyond those listed under "absolute maximum ratings" may cause permanent damage to the device. These are stress ratings only, and functional operation of the device at these or any other conditions beyond those indicated under "recommended operating conditions" is not implied. Exposure to absolute-maximum-rated conditions for extended periods may affect device reliability.
- (2) These voltages represent the dc voltage + peak ac waveform measured at the terminal of the device in all conditions.

**ORDERING INFORMATION**

T <sub>A</sub>	PACKAGE	DESCRIPTION
0°C to 70°C	TAS5142DKD	36-pin PSOP3
0°C to 70°C	TAS5142DDV	44-pin HTSSOP

For the most current specification and package information, see the TI Web site at [www.ti.com](http://www.ti.com).

**Terminal Functions**

TERMINAL			FUNCTION (1)	DESCRIPTION
NAME	DKD NO.	DDV NO.		
AGND	9	11	P	Analog ground
BST_A	35	43	P	HS bootstrap supply (BST), external capacitor to OUT_A required
BST_B	28	34	P	HS bootstrap supply (BST), external capacitor to OUT_B required
BST_C	27	33	P	HS bootstrap supply (BST), external capacitor to OUT_C required
BST_D	20	24	P	HS bootstrap supply (BST), external capacitor to OUT_D required
GND	8	10	P	Ground
GND_A	32	38	P	Power ground for half-bridge A
GND_B	31	37	P	Power ground for half-bridge B
GND_C	24	30	P	Power ground for half-bridge C
GND_D	23	29	P	Power ground for half-bridge D
GVDD_A	36	44	P	Gate-drive voltage supply requires 0.1- $\mu$ F capacitor to AGND
GVDD_B	1	1	P	Gate-drive voltage supply requires 0.1- $\mu$ F capacitor to AGND
GVDD_C	18	22	P	Gate-drive voltage supply requires 0.1- $\mu$ F capacitor to AGND
GVDD_D	19	23	P	Gate-drive voltage supply requires 0.1- $\mu$ F capacitor to AGND
M1	13	15	I	Mode selection pin
M2	12	14	I	Mode selection pin
M3	11	13	I	Mode selection pin
NC	–	3, 4, 19, 20, 25, 42	–	No connect. Pins may be grounded.
OC_ADJ	7	9	O	Analog overcurrent programming pin requires resistor to ground
OTW	2	2	O	Overtemperature warning signal, open-drain, active-low
OUT_A	33	39	O	Output, half-bridge A
OUT_B	30	36	O	Output, half-bridge B
OUT_C	25	31	O	Output, half-bridge C
OUT_D	22	28	O	Output, half-bridge D
PVDD_A	34	40, 41	P	Power supply input for half-bridge A requires close decoupling of 0.1- $\mu$ F capacitor to GND_A.
PVDD_B	29	35	P	Power supply input for half-bridge B requires close decoupling of 0.1- $\mu$ F capacitor to GND_B.
PVDD_C	26	32	P	Power supply input for half-bridge C requires close decoupling of 0.1- $\mu$ F capacitor to GND_C.
PVDD_D	21	26, 27	P	Power supply input for half-bridge D requires close decoupling of 0.1- $\mu$ F capacitor to GND_D.
PWM_A	4	6	I	Input signal for half-bridge A
PWM_B	6	8	I	Input signal for half-bridge B
PWM_C	14	16	I	Input signal for half-bridge C
PWM_D	16	18	I	Input signal for half-bridge D
RESET_AB	5	7	I	Reset signal for half-bridge A and half-bridge B, active-low
RESET_CD	15	17	I	Reset signal for half-bridge C and half-bridge D, active-low
$\overline{SD}$	3	5	O	Shutdown signal, open-drain, active-low
VDD	17	21	P	Power supply for digital voltage regulator requires 0.1- $\mu$ F capacitor to GND.
VREG	10	12	P	Digital regulator supply filter pin requires 0.1- $\mu$ F capacitor to AGND.

(1) I = input, O = output, P = power

SYSTEM BLOCK DIAGRAM

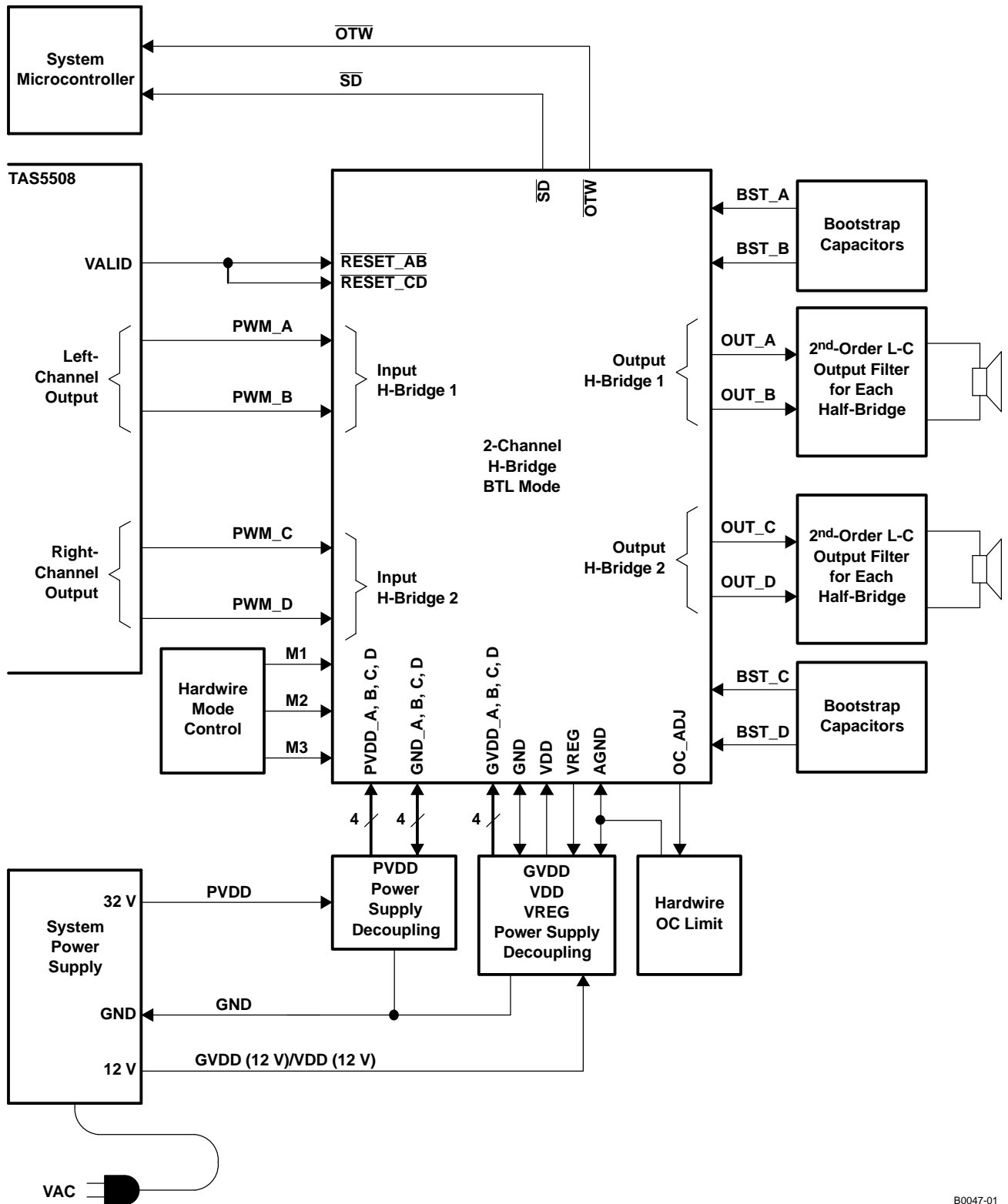

**FUNCTIONAL BLOCK DIAGRAM**

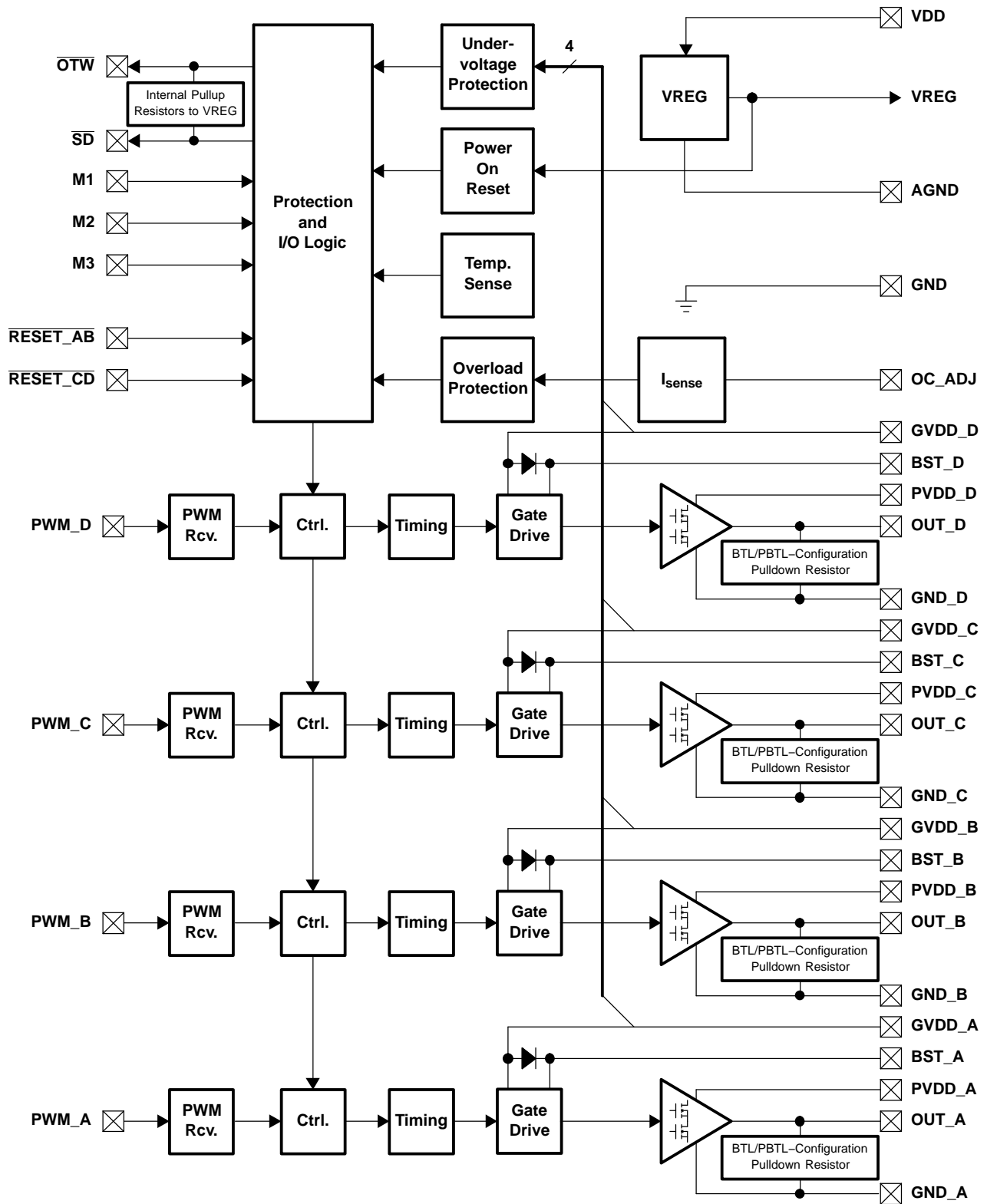

B0034-02

**RECOMMENDED OPERATING CONDITIONS**

			MIN	TYP	MAX	UNIT
PVDD_X	Half-bridge supply	DC supply voltage	0	32	34	V
GVDD_X	Supply for logic regulators and gate-drive circuitry	DC supply voltage	10.8	12	13.2	V
VDD	Digital regulator input	DC supply voltage	10.8	12	13.2	V
R <sub>L</sub> (BTL)	Load impedance	Output filter: L = 10 μH, C = 470 nF. Output AD modulation, switching frequency > 350 kHz	3	4		Ω
R <sub>L</sub> (SE)			2	3		
R <sub>L</sub> (PBTL)			1.5	2		
L <sub>Output</sub> (BTL)	Output-filter inductance	Minimum output inductance under short-circuit condition	5	10		μH
L <sub>Output</sub> (SE)			5	10		
L <sub>Output</sub> (PBTL)			5	10		
F <sub>PWM</sub>	PWM frame rate		192	384	432	kHz
T <sub>J</sub>	Junction temperature		0		125	°C

**AUDIO SPECIFICATIONS (BTL)**

PVDD\_X = 32 V, GVDD = VDD = 12 V, BTL mode, R<sub>L</sub> = 4 Ω, audio frequency = 1 kHz, AES17 filter, F<sub>PWM</sub> = 384 kHz, case temperature = 75°C, unless otherwise noted. Audio performance is recorded as a chipset, using TAS5508 PWM processor with an effective modulation index limit of 96.1%. All performance is in accordance with recommended operating conditions unless otherwise specified.

PARAMETER	TEST CONDITIONS	TAS5142			UNIT
		MIN	TYP	MAX	
P <sub>O</sub>	Power output per channel, DKD package	R <sub>L</sub> = 4 Ω, 10% THD, clipped input signal		100	W
		R <sub>L</sub> = 6 Ω, 10% THD, clipped input signal		80	
		R <sub>L</sub> = 8 Ω, 10% THD, clipped input signal		65	
		R <sub>L</sub> = 4 Ω, 0 dBFS, unclipped input signal		80	
		R <sub>L</sub> = 6 Ω, 0 dBFS, unclipped input signal		60	
		R <sub>L</sub> = 8 Ω, 0 dBFS, unclipped input signal		50	
THD+N	Total harmonic distortion + noise	0 dBFS		0.3%	
		1 W		0.1%	
V <sub>n</sub>	Output integrated noise	A-weighted		140	μV
SNR	Signal-to-noise ratio <sup>(1)</sup>	A-weighted		102	dB
DNR	Dynamic range	A-weighted, input level = –60 dBFS using TAS5508 modulator		102	dB
		A-weighted, input level = –60 dBFS using TAS5518 modulator		110	
P <sub>idle</sub>	Power dissipation due to idle losses (IPVDD_X)	P <sub>O</sub> = 0 W, 4 channels switching <sup>(2)</sup>		2	W

(1) SNR is calculated relative to 0-dBFS input level.

(2) Actual system idle losses are affected by core losses of output inductors.

**AUDIO SPECIFICATIONS (Single-Ended Output)**

PVDD\_X = 32 V, GVDD = VDD = 12 V, SE mode, R<sub>L</sub> = 4 Ω, audio frequency = 1 kHz, AES17 filter, F<sub>PWM</sub> = 384 kHz, case temperature = 75°C, unless otherwise noted. Audio performance is recorded as a chipset, using TAS5086 PWM processor with an effective modulation index limit of 96.1%. All performance is in accordance with recommended operating conditions



**AUDIO SPECIFICATIONS (Single-Ended Output) (continued)**

PVDD\_X = 32 V, GVDD = VDD = 12 V, SE mode,  $R_L = 4 \Omega$ , audio frequency = 1 kHz, AES17 filter,  $F_{PWM} = 384$  kHz, case temperature = 75°C, unless otherwise noted. Audio performance is recorded as a chipset, using TAS5086 PWM processor with an effective modulation index limit of 96.1%. All performance is in accordance with recommended operating conditions unless otherwise specified.

unless otherwise specified.

PARAMETER	TEST CONDITIONS	TAS5142			UNIT
		MIN	TYP	MAX	
$P_O$ Power output per channel, DKD package	$R_L = 3 \Omega$ , 10% THD, clipped input signal		40		W
	$R_L = 4 \Omega$ , 10% THD, clipped input signal		30		
	$R_L = 3 \Omega$ , 0 dBFS, unclipped input signal		30		
	$R_L = 4 \Omega$ , 0 dBFS, unclipped input signal		20		
THD+N Total harmonic distortion + noise	0 dBFS		0.2%		
	1 W		0.1%		
$V_n$ Output integrated noise	A-weighted		90		$\mu$ V
SNR Signal-to-noise ratio <sup>(1)</sup>	A-weighted		100		dB
DNR Dynamic range	A-weighted, input level = -60 dBFS using TAS5508 modulator		100		dB
$P_{idle}$ Power dissipation due to idle losses (IPVDD_X)	$P_O = 0$ W, 4 channels switching <sup>(2)</sup>		2		W

(1) SNR is calculated relative to 0-dBFS input level.

(2) Actual system idle losses are affected by core losses of output inductors.

**AUDIO SPECIFICATIONS (PBTL)**

PVDD\_X = 32 V, GVDD = VDD = 12 V, PBTL mode,  $R_L = 3 \Omega$ , audio frequency = 1 kHz, AES17 filter,  $F_{PWM} = 384$  kHz, case temperature = 75°C, unless otherwise noted. Audio performance is recorded as a chipset, using TAS5508 PWM processor with an effective modulation index limit of 96.1%. All performance is in accordance with recommended operating conditions unless otherwise specified.

PARAMETER	TEST CONDITIONS	TAS5142			UNIT
		MIN	TYP	MAX	
$P_O$ Power output per channel, DKD package	$R_L = 3 \Omega$ , 10% THD, clipped input signal		160		W
	$R_L = 2 \Omega$ , 10% THD, clipped input signal		200		
	$R_L = 3 \Omega$ , 0 dBFS, unclipped input signal		120		
	$R_L = 2 \Omega$ , 0 dBFS, unclipped input signal		150		
THD+N Total harmonic distortion + noise	0 dBFS		0.2%		
	1 W		0.1%		
$V_n$ Output integrated noise	A-weighted		140		$\mu$ V
SNR Signal-to-noise ratio <sup>(1)</sup>	A-weighted		102		dB
DNR Dynamic range	A-weighted, input level = -60 dBFS using TAS5508 modulator		102		dB
	A-weighted, input level = -60 dBFS using TAS5518 modulator		110		
$P_{idle}$ Power dissipation due to idle losses (IPVDD_X)	$P_O = 0$ W, 1 channel switching <sup>(2)</sup>		2		W

(1) SNR is calculated relative to 0-dBFS input level.

(2) Actual system idle losses are affected by core losses of output inductors.

## ELECTRICAL CHARACTERISTICS

$R_L = 4\ \Omega$ ,  $F_{PWM} = 384\ \text{kHz}$ , unless otherwise noted. All performance is in accordance with recommended operating conditions unless otherwise specified.

PARAMETER	TEST CONDITIONS	TAS5142			UNIT
		MIN	TYP	MAX	
<b>Internal Voltage Regulator and Current Consumption</b>					
VREG	Voltage regulator, only used as a reference node	VDD = 12 V			V
IVDD	VDD supply current	Operating, 50% duty cycle			mA
		Idle, reset mode			
IGVDD_X	Gate supply current per half-bridge	50% duty cycle			mA
		Reset mode			
IPVDD_X	Half-bridge idle current	50% duty cycle, without output filter or load			mA
		Reset mode, no switching			
<b>Output Stage MOSFETs</b>					
$R_{DSon,LS}$	Drain-to-source resistance, LS	$T_J = 25^\circ\text{C}$ , includes metallization resistance, GVDD = 12 V			m $\Omega$
$R_{DSon,HS}$	Drain-to-source resistance, HS	$T_J = 25^\circ\text{C}$ , includes metallization resistance, GVDD = 12 V			m $\Omega$
<b>I/O Protection</b>					
$V_{uvp,G}$	Undervoltage protection limit, GVDD_X	9.8			V
$V_{uvp,hyst}^{(1)}$		250			mV
OTW <sup>(1)</sup>	Overtemperature warning	115	125	135	$^\circ\text{C}$
OTW <sub>HYST</sub> <sup>(1)</sup>	Temperature drop needed below OTW temp. for $\overline{\text{OTW}}$ to be inactive after the $\overline{\text{OTW}}$ event	25			$^\circ\text{C}$
OTE <sup>(1)</sup>	Overtemperature error	145	155	165	$^\circ\text{C}$
OTE-OTW <sub>differential</sub> <sup>(1)</sup>	OTE-OTW differential	30			$^\circ\text{C}$
OTE <sub>HYST</sub> <sup>(1)</sup>	A reset event must occur for $\overline{\text{SD}}$ to be released following an OTE event.	25			$^\circ\text{C}$
OLPC	Overload protection counter	$F_{PWM} = 384\ \text{kHz}$			ms
$I_{OC}$	Overcurrent limit protection	Resistor—programmable, high-end, $R_{OCP} = 18\ \text{k}\Omega$			A
$I_{OCT}$	Overcurrent response time	210			ns
$R_{OCP}$	OC programming resistor range	Resistor tolerance = 5%			k $\Omega$
$R_{PD}$	Internal pulldown resistor at the output of each half-bridge	Connected when $\overline{\text{RESET}}$ is active to provide bootstrap capacitor charge. Not used in SE mode			k $\Omega$
<b>Static Digital Specifications</b>					
$V_{IH}$	High-level input voltage	PWM_A, PWM_B, PWM_C, PWM_D, M1, M2, M3, RESET_AB, RESET_CD			V
$V_{IL}$	Low-level input voltage	2			V
Leakage	Input leakage current	-10			$\mu\text{A}$
<b>OTW/SHUTDOWN (SD)</b>					
$R_{INT\_PU}$	Internal pullup resistance, $\overline{\text{OTW}}$ to VREG, $\overline{\text{SD}}$ to VREG	20	26	32	k $\Omega$
$V_{OH}$	High-level output voltage	Internal pullup resistor			V
		External pullup of 4.7 k $\Omega$ to 5 V			
$V_{OL}$	Low-level output voltage	$I_O = 4\ \text{mA}$			V
FANOUT	Device fanout $\overline{\text{OTW}}$ , $\overline{\text{SD}}$	No external pullup			Devices

(1) Specified by design

**TYPICAL CHARACTERISTICS, BTL CONFIGURATION**

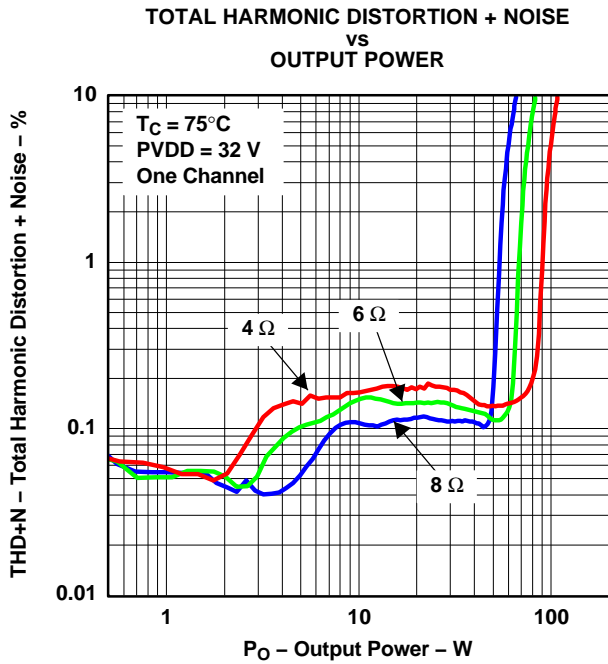

Figure 1.

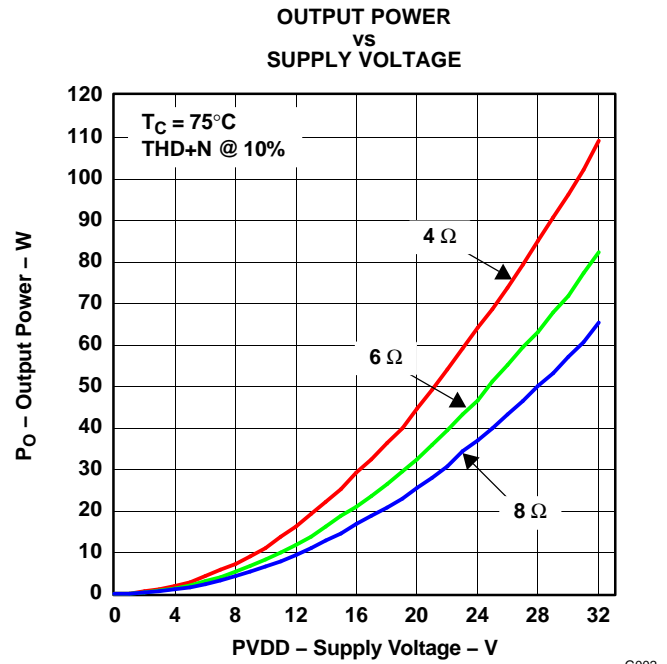

Figure 2.

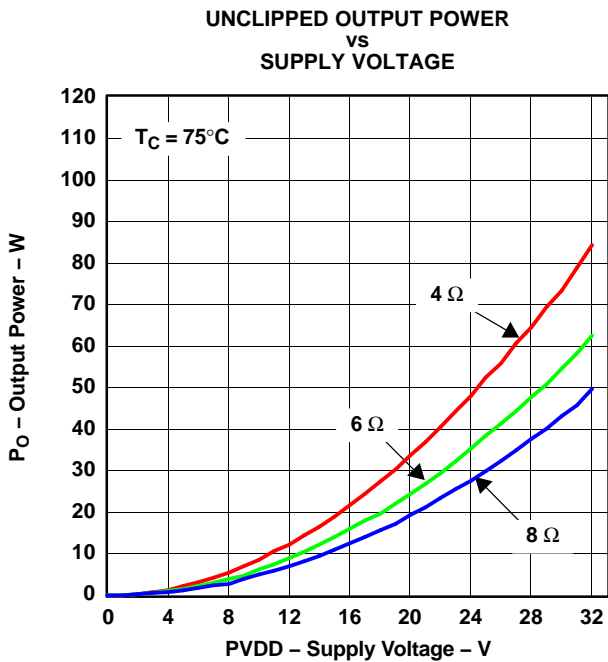

Figure 3.

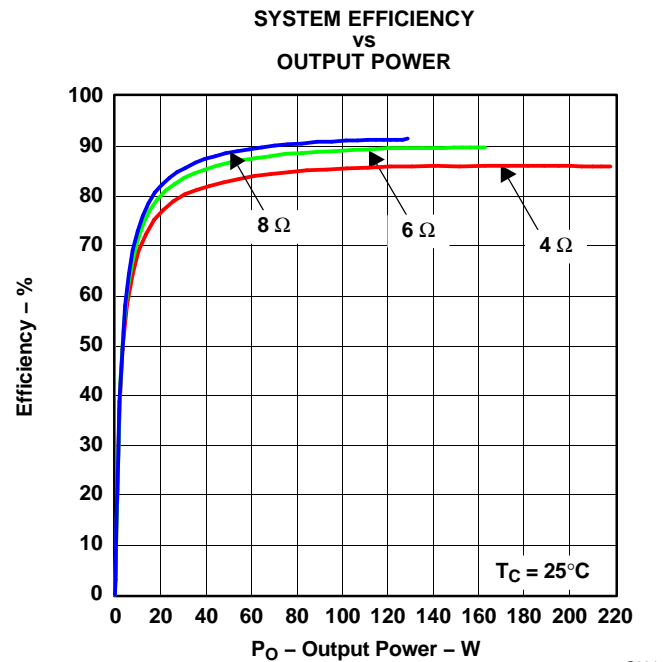

Figure 4.

TYPICAL CHARACTERISTICS, BTL CONFIGURATION (continued)

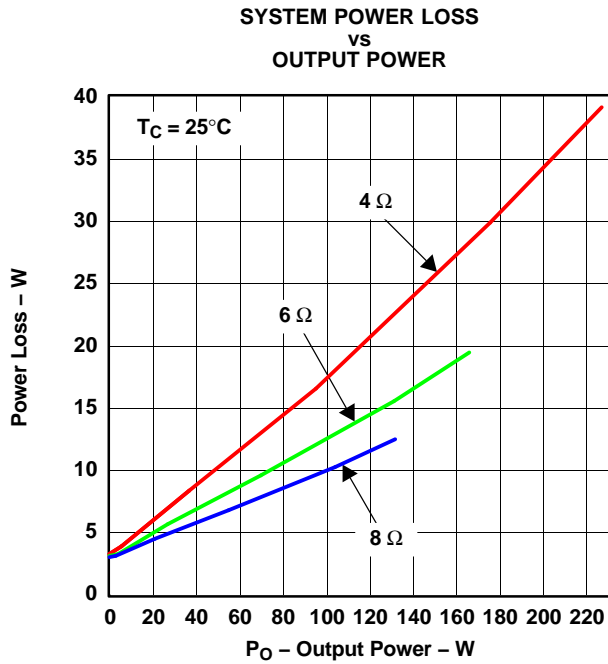

Figure 5.

G005

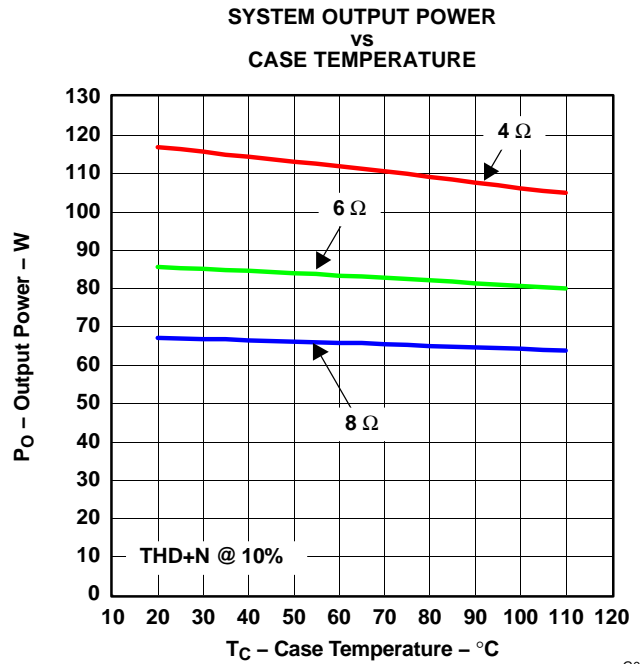

Figure 6.

G006

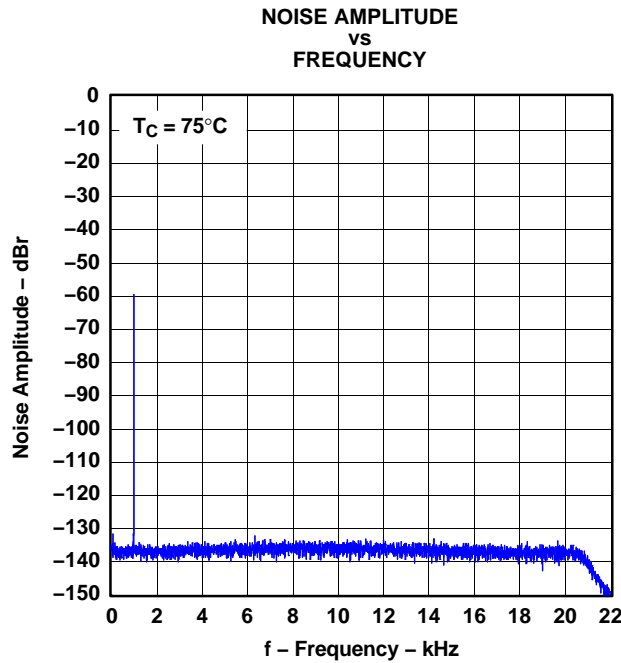

Figure 7.

G007

**TYPICAL CHARACTERISTICS, SE CONFIGURATION**

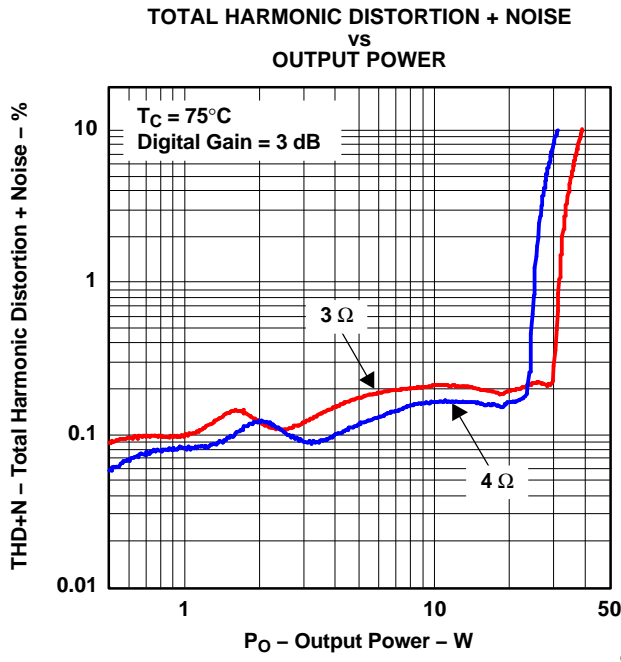

Figure 8.

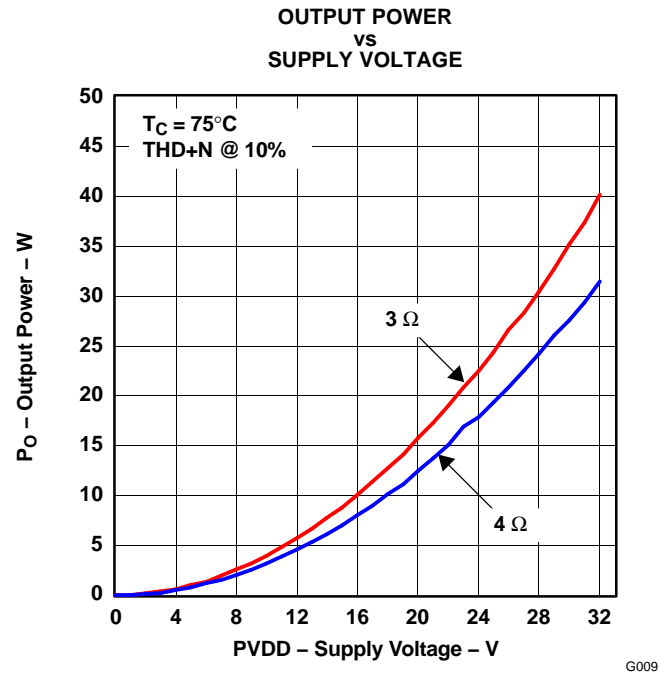

Figure 9.

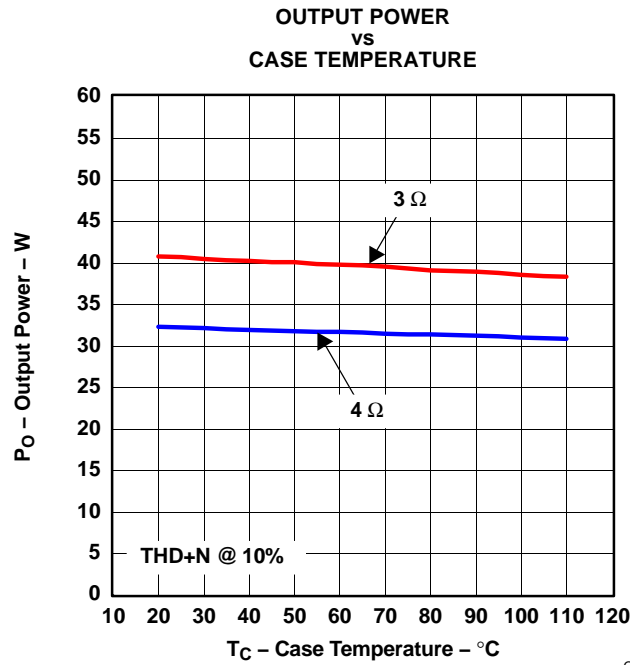

Figure 10.

TYPICAL CHARACTERISTICS, PBTL CONFIGURATION

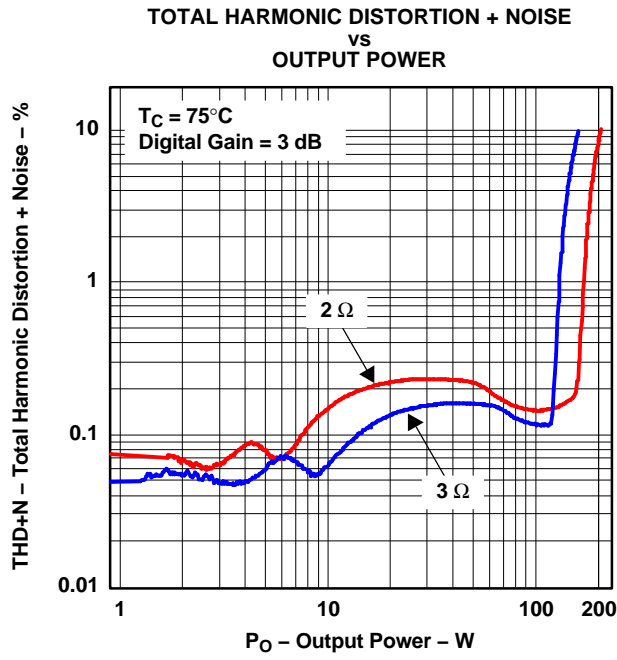

Figure 11.

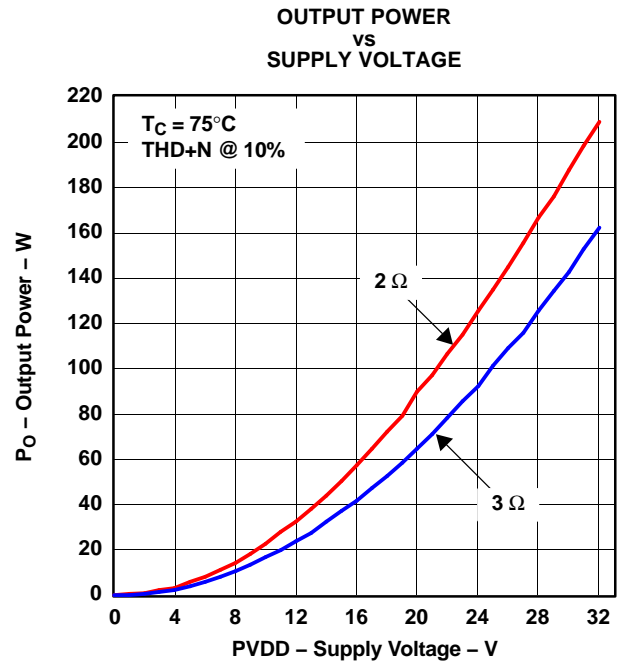

Figure 12.

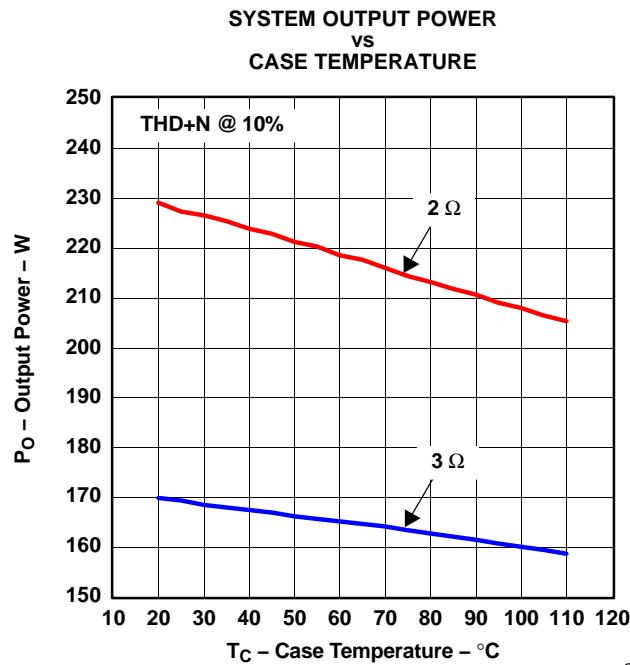
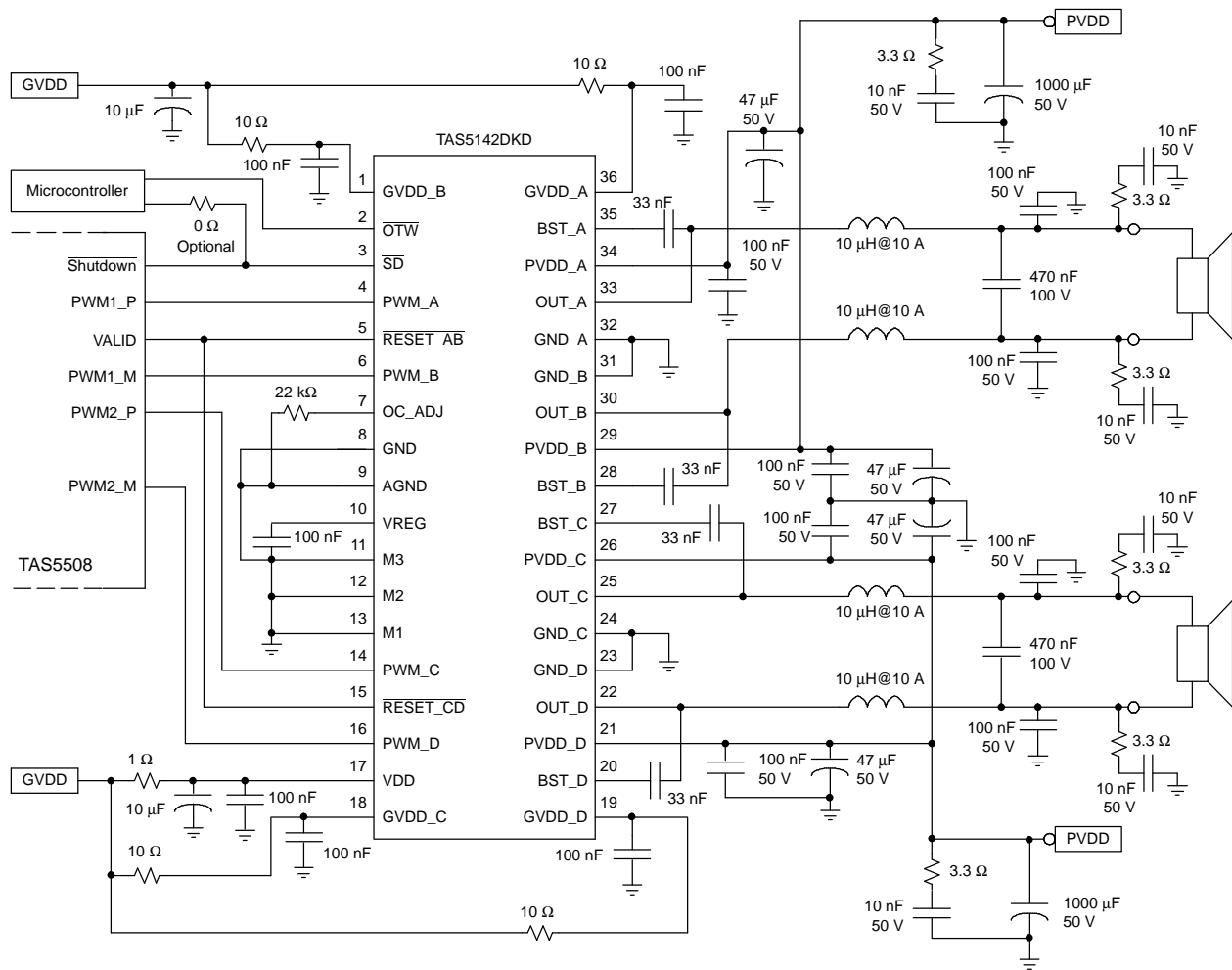

Figure 13.



S0070-01

**Figure 14. Typical Differential (2N) BTL Application With AD Modulation Filters**





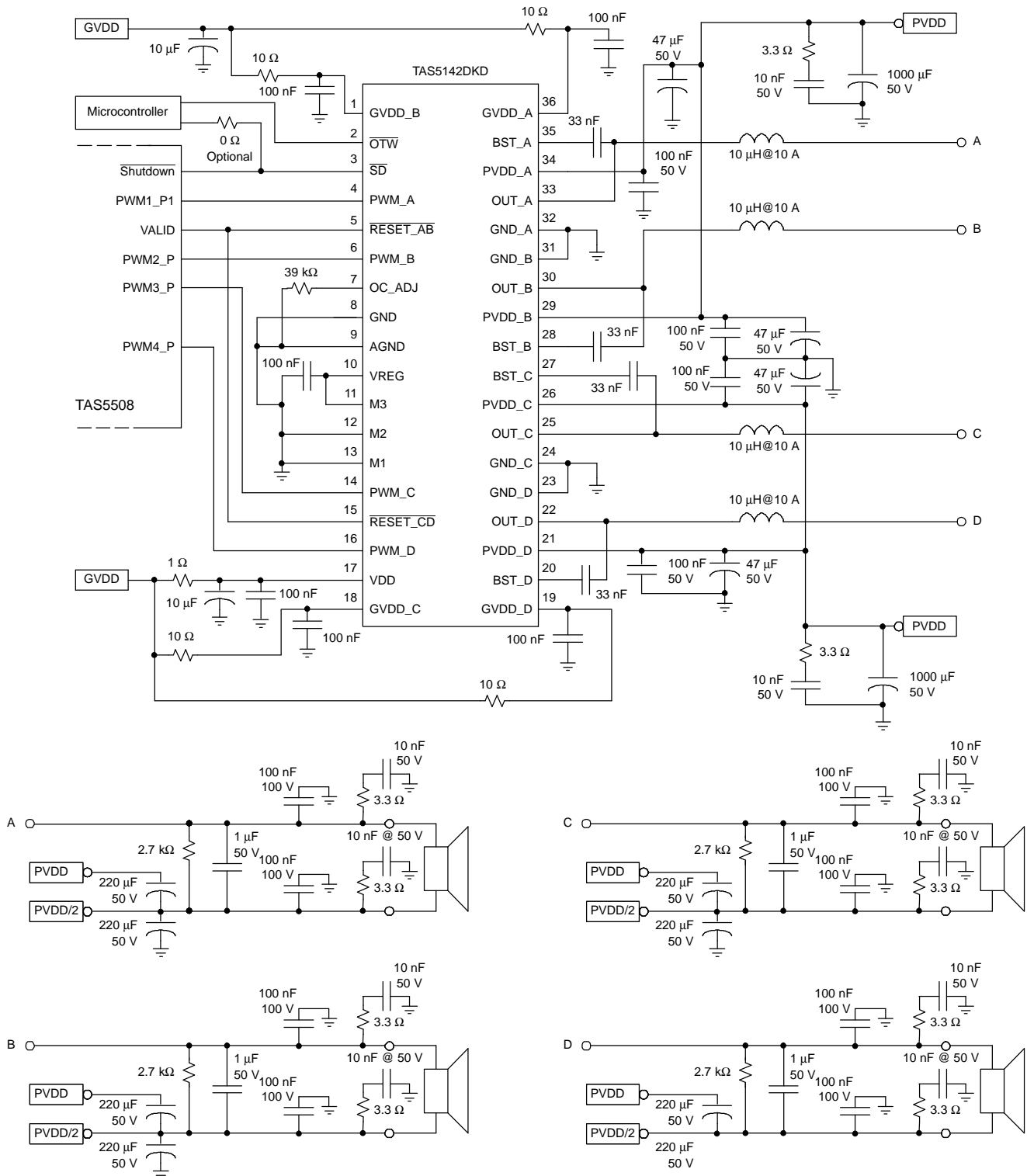

S0071-01

**Figure 16. Typical SE Application**

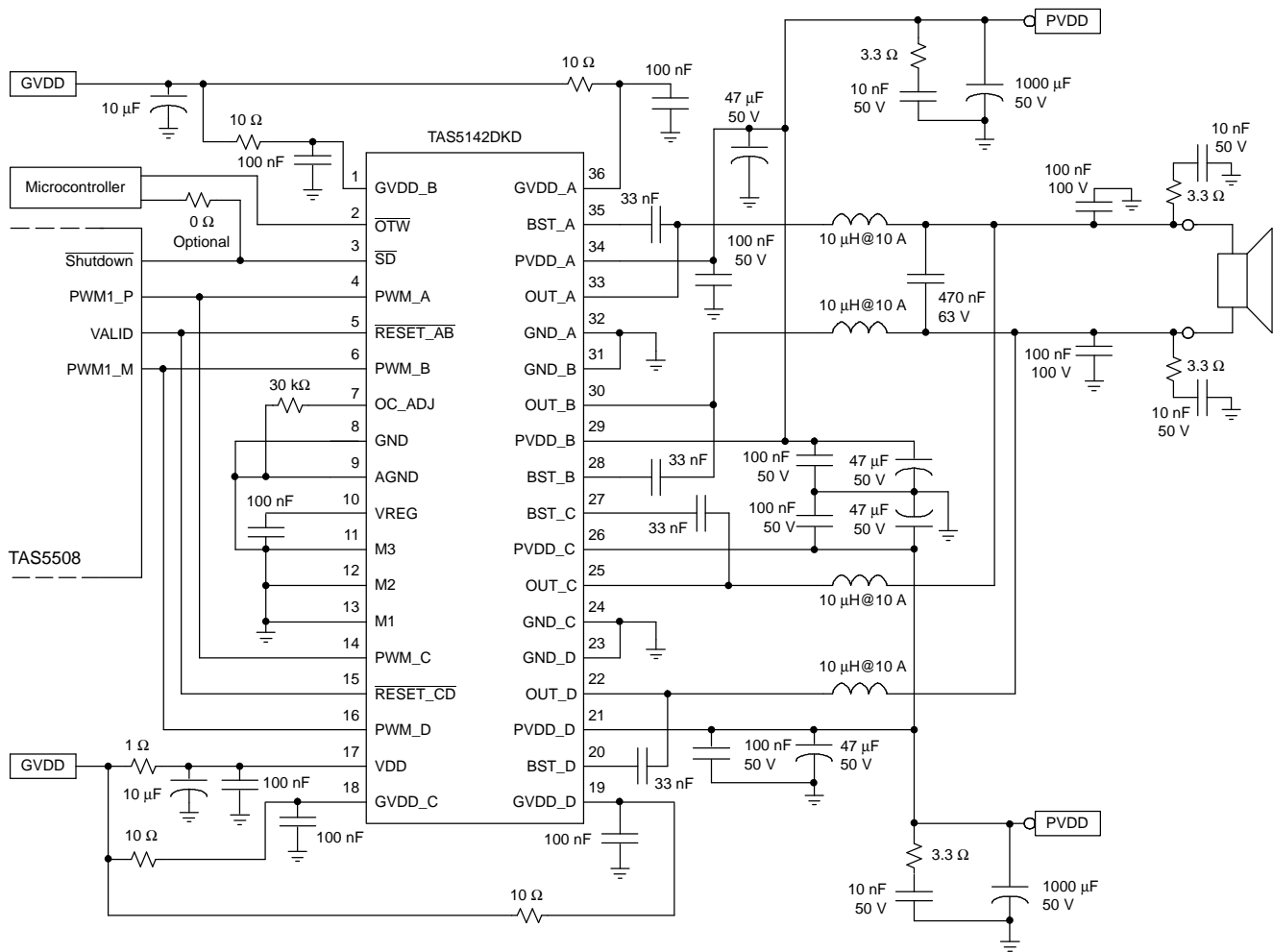

S0070-03

Figure 17. Typical Differential (2N) PBTL Application With AD Modulation Filters

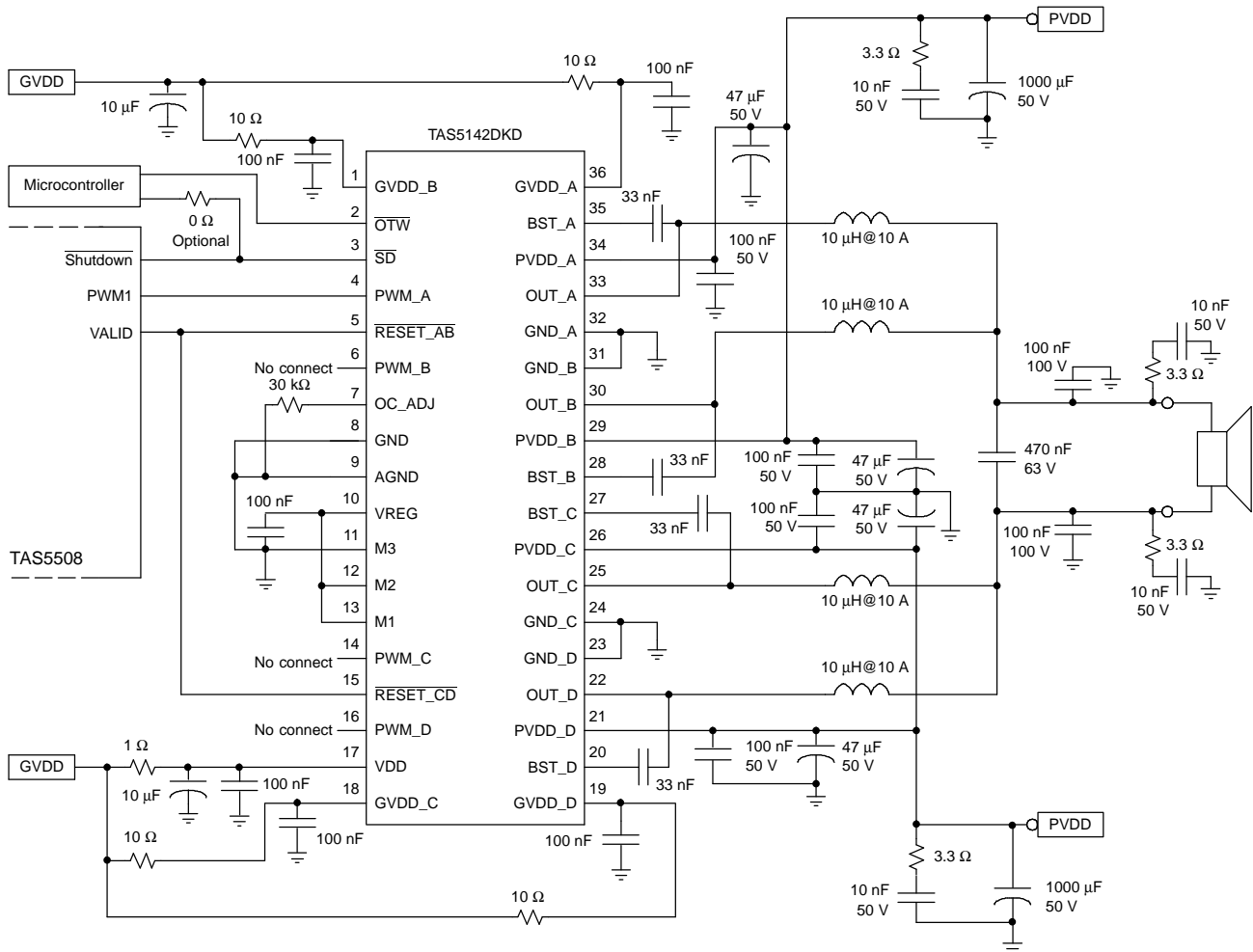

S0070-04

**Figure 18. Typical Non-Differential (1N) PBTl Application**

## THEORY OF OPERATION

### POWER SUPPLIES

To facilitate system design, the TAS5142 needs only a 12-V supply in addition to the (typical) 32-V power-stage supply. An internal voltage regulator provides suitable voltage levels for the digital and low-voltage analog circuitry. Additionally, all circuitry requiring a floating voltage supply, e.g., the high-side gate drive, is accommodated by built-in bootstrap circuitry requiring only a few external capacitors.

In order to provide outstanding electrical and acoustical characteristics, the PWM signal path including gate drive and output stage is designed as identical, independent half-bridges. For this reason, each half-bridge has separate gate drive supply (GVDD\_X), bootstrap pins (BST\_X), and power-stage supply pins (PVDD\_X). Furthermore, an additional pin (VDD) is provided as supply for all common circuits. Although supplied from the same 12-V source, it is highly recommended to separate GVDD\_A, GVDD\_B, GVDD\_C, GVDD\_D, and VDD on the printed-circuit board (PCB) by RC filters (see application diagram for details). These RC filters provide the recommended high-frequency isolation. Special attention should be paid to placing all decoupling capacitors as close to their associated pins as possible. In general, inductance between the power supply pins and decoupling capacitors must be avoided. (See reference board documentation for additional information.)

For a properly functioning bootstrap circuit, a small ceramic capacitor must be connected from each bootstrap pin (BST\_X) to the power-stage output pin (OUT\_X). When the power-stage output is low, the bootstrap capacitor is charged through an internal diode connected between the gate-drive power-supply pin (GVDD\_X) and the bootstrap pin. When the power-stage output is high, the bootstrap capacitor potential is shifted above the output potential and thus provides a suitable voltage supply for the high-side gate driver. In an application with PWM switching frequencies in the range from 352 kHz to 384 kHz, it is recommended to use 33-nF ceramic capacitors, size 0603 or 0805, for the bootstrap supply. These 33-nF capacitors ensure sufficient energy storage, even during minimal PWM duty cycles, to keep the high-side power stage FET (LDMOS) fully turned on during the remaining part of the PWM cycle. In an application running at a reduced switching frequency, generally 192 kHz, the bootstrap capacitor might need to be increased in value.

Special attention should be paid to the power-stage power supply; this includes component selection, PCB placement, and routing. As indicated, each half-bridge has independent power-stage supply pins (PVDD\_X). For optimal electrical performance, EMI compliance, and system reliability, it is important that each PVDD\_X pin is decoupled with a 100-nF ceramic capacitor placed as close as possible to each supply pin. It is recommended to follow the PCB layout of the TAS5142 reference design. For additional information on recommended power supply and required components, see the application diagrams given previously in this data sheet.

The 12-V supply should be from a low-noise, low-output-impedance voltage regulator. Likewise, the 32-V power-stage supply is assumed to have low output impedance and low noise. The power-supply sequence is not critical as facilitated by the internal power-on-reset circuit. Moreover, the TAS5142 is fully protected against erroneous power-stage turnon due to parasitic gate charging. Thus, voltage-supply ramp rates (dV/dt) are non-critical within the specified range (see the *Recommended Operating Conditions* section of this data sheet).

### SYSTEM POWER-UP/POWER-DOWN SEQUENCE

#### Powering Up

The TAS5142 does not require a power-up sequence. The outputs of the H-bridges remain in a high-impedance state until the gate-drive supply voltage (GVDD\_X) and VDD voltage are above the undervoltage protection (UVP) voltage threshold (see the *Electrical Characteristics* section of this data sheet). Although not specifically required, it is recommended to hold  $\overline{\text{RESET\_AB}}$  and  $\overline{\text{RESET\_CD}}$  in a low state while powering up the device. This allows an internal circuit to charge the external bootstrap capacitors by enabling a weak pulldown of the half-bridge output.

When the TAS5142 is being used with TI PWM modulators such as the TAS5508, no special attention to the state of  $\overline{\text{RESET\_AB}}$  and  $\overline{\text{RESET\_CD}}$  is required, provided that the chipset is configured as recommended.

#### Powering Down

The TAS5142 does not require a power-down sequence. The device remains fully operational as long as the gate-drive supply (GVDD\_X) voltage and VDD voltage are above the undervoltage protection (UVP) voltage threshold (see the *Electrical*

*Characteristics* section of this data sheet). Although not specifically required, it is a good practice to hold  $\overline{\text{RESET\_AB}}$  and  $\overline{\text{RESET\_CD}}$  low during power down, thus preventing audible artifacts including pops or clicks.

When the TAS5142 is being used with TI PWM modulators such as the TAS5508, no special attention to the state of  $\overline{\text{RESET\_AB}}$  and  $\overline{\text{RESET\_CD}}$  is required, provided that the chipset is configured as recommended.

## ERROR REPORTING

The  $\overline{\text{SD}}$  and  $\overline{\text{OTW}}$  pins are both active-low, open-drain outputs. Their function is for protection-mode signaling to a PWM controller or other system-control device.

Any fault resulting in device shutdown is signaled by the  $\overline{\text{SD}}$  pin going low. Likewise,  $\overline{\text{OTW}}$  goes low when the device junction temperature exceeds 125°C (see the following table).

$\overline{\text{SD}}$	$\overline{\text{OTW}}$	DESCRIPTION
0	0	Overtemperature (OTE) or overload (OLP) or undervoltage (UVP)
0	1	Overload (OLP) or undervoltage (UVP)
1	0	Junction temperature higher than 125°C (overtemperature warning)
1	1	Junction temperature lower than 125°C and no OLP or UVP faults (normal operation)

Note that asserting either  $\overline{\text{RESET\_AB}}$  or  $\overline{\text{RESET\_CD}}$  low forces the  $\overline{\text{SD}}$  signal high, independent of faults being present. TI recommends monitoring the  $\overline{\text{OTW}}$  signal using the system microcontroller and responding to an overtemperature warning signal by, e.g., turning down the volume to prevent further heating of the device resulting in device shutdown (OTE).

To reduce external component count, an internal pullup resistor to 3.3 V is provided on both  $\overline{\text{SD}}$  and  $\overline{\text{OTW}}$  outputs. Level compliance for 5-V logic can be obtained by adding external pullup resistors to 5 V (see the *Electrical Characteristics* section of this data sheet for further specifications).

## DEVICE PROTECTION SYSTEM

The TAS5142 contains advanced protection circuitry carefully designed to facilitate system integration and ease of use, as well as to safeguard the device from permanent failure due to a wide range of fault conditions such as short circuits, overload, overtemperature, and undervoltage. The TAS5142 responds to a fault by immediately setting the power stage in a high-impedance (Hi-Z) state and asserting the  $\overline{\text{SD}}$  pin low. In situations other than overload, the device automatically recovers when the fault condition has been removed, i.e., the junction

temperature has dropped or the supply voltage has increased. For highest possible reliability, recovering from an overload fault requires external reset of the device (see the *Device Reset* section of this data sheet) no sooner than 1 second after the shutdown.

## Use of TAS5142 in High-Modulation-Index Capable Systems

This device requires at least 50 ns of low time on the output per 384-kHz PWM frame rate in order to keep the bootstrap capacitors charged. As an example, if the modulation index is set to 99.2% in the TAS5508, this setting allows PWM pulse durations down to 20 ns. This signal, which does not meet the 50-ns requirement, is sent to the PWM\_X pin and this low-state pulse time does not allow the bootstrap capacitor to stay charged. In this situation, the low voltage across the bootstrap capacitor can cause a failure of the high-side MOSFET transistor, especially when driving a low-impedance load. The TAS5142 device requires limiting the TAS5508 modulation index to 96.1% to keep the bootstrap capacitor charged under all signals and loads.

Therefore, TI strongly recommends using a TI PWM processor, such as TAS5508 or TAS5086, with the modulation index set at 96.1% to interface with TAS5142.

## Overcurrent (OC) Protection With Current Limiting and Overload Detection

The device has independent, fast-reacting current detectors with programmable trip threshold (OC threshold) on all high-side and low-side power-stage FETs. See the following table for OC-adjust resistor values. The detector outputs are closely monitored by two protection systems. The first protection system controls the power stage in order to prevent the output current from further increasing, i.e., it performs a current-limiting function rather than prematurely shutting down during combinations of high-level music transients and extreme speaker load impedance drops. If the high-current situation persists, i.e., the power stage is being overloaded, a second protection system triggers a latching shutdown, resulting in the power stage being set in the high-impedance (Hi-Z) state. Current limiting and overload protection are independent for half-bridges A and B and, respectively, C and D. That is, if the bridge-tied load between half-bridges A and B causes an overload fault, only half-bridges A and B are shut down.

- For the lowest-cost bill of materials in terms of component selection, the OC threshold measure should be limited, considering the power output requirement and minimum load impedance. Higher-impedance loads require a lower OC threshold.

- The demodulation-filter inductor must retain at least 5  $\mu\text{H}$  of inductance at twice the OC threshold setting.

Unfortunately, most inductors have decreasing inductance with increasing temperature and increasing current (saturation). To some degree, an increase in temperature naturally occurs when operating at high output currents, due to core losses and the dc resistance of the inductor's copper winding. A thorough analysis of inductor saturation and thermal properties is strongly recommended.

Setting the OC threshold too low might cause issues such as lack of enough output power and/or unexpected shutdowns due to too-sensitive overload detection.

In general, it is recommended to follow closely the external component selection and PCB layout as given in the *Application* section.

For added flexibility, the OC threshold is programmable within a limited range using a single external resistor connected between the OC\_ADJ pin and AGND. (See the *Electrical Characteristics* section of this data sheet for information on the correlation between programming-resistor value and the OC threshold.) It should be noted that a properly functioning overcurrent detector assumes the presence of a properly designed demodulation filter at the power-stage output. Short-circuit protection is not provided directly at the output pins of the power stage but only on the speaker terminals (after the demodulation filter). It is required to follow certain guidelines when selecting the OC threshold and an appropriate demodulation inductor:

OC-Adjust Resistor Values (k $\Omega$ )	Max. Current Before OC Occurs (A)
22	9.4
27	8.6
39	6.4
47	6
69	4.7

### Overtemperature Protection

The TAS5142 has a two-level temperature-protection system that asserts an active-low warning signal (OTW) when the device junction temperature exceeds 125°C (nominal) and, if the device junction temperature exceeds 155°C (nominal), the device is

put into thermal shutdown, resulting in all half-bridge outputs being set in the high-impedance (Hi-Z) state and  $\overline{\text{SD}}$  being asserted low. OTE is latched in this case. To clear the OTE latch, both  $\overline{\text{RESET\_AB}}$  and  $\overline{\text{RESET\_CD}}$  must be asserted. Thereafter, the device resumes normal operation.

### Undervoltage Protection (UVP) and Power-On Reset (POR)

The UVP and POR circuits of the TAS5142 fully protect the device in any power-up/down and brownout situation. While powering up, the POR circuit resets the overload circuit (OLP) and ensures that all circuits are fully operational when the GVDD\_X and VDD supply voltages reach 9.8 V (typical). Although GVDD\_X and VDD are independently monitored, a supply voltage drop below the UVP threshold on any VDD or GVDD\_X pin results in all half-bridge outputs immediately being set in the high-impedance (Hi-Z) state and  $\overline{\text{SD}}$  being asserted low. The device automatically resumes operation when all supply voltages have increased above the UVP threshold.

### DEVICE RESET

Two reset pins are provided for independent control of half-bridges A/B and C/D. When  $\overline{\text{RESET\_AB}}$  is asserted low, all four power-stage FETs in half-bridges A and B are forced into a high-impedance (Hi-Z) state. Likewise, asserting  $\overline{\text{RESET\_CD}}$  low forces all four power-stage FETs in half-bridges C and D into a high-impedance state. Thus, both reset pins are well suited for hard-muting the power stage if needed.

In BTL modes, to accommodate bootstrap charging prior to switching start, asserting the reset inputs low enables weak pulldown of the half-bridge outputs. In the SE mode, the weak pulldowns are not enabled, and it is therefore recommended to ensure bootstrap capacitor charging by providing a low pulse on the PWM inputs when reset is asserted high.

Asserting either reset input low removes any fault information to be signalled on the  $\overline{\text{SD}}$  output, i.e.,  $\overline{\text{SD}}$  is forced high.

A rising-edge transition on either reset input allows the device to resume operation after an overload fault.

## PACKAGING INFORMATION

Orderable Device	Status (1)	Package Type	Package Drawing	Pins	Package Qty	Eco Plan (2)	Lead finish/ Ball material (6)	MSL Peak Temp (3)	Op Temp (°C)	Device Marking (4/5)	Samples
TAS5142DDV	ACTIVE	HTSSOP	DDV	44	35	RoHS & Green	NIPDAU	Level-3-260C-168 HR	0 to 70	TAS5142	<a href="#">Samples</a>
TAS5142DDVR	ACTIVE	HTSSOP	DDV	44	2000	RoHS & Green	NIPDAU	Level-3-260C-168 HR	0 to 70	TAS5142	<a href="#">Samples</a>
TAS5142DDVRG4	ACTIVE	HTSSOP	DDV	44	2000	RoHS & Green	NIPDAU	Level-3-260C-168 HR	0 to 70	TAS5142	<a href="#">Samples</a>
TAS5142DKD	ACTIVE	HSSOP	DKD	36	29	RoHS & Green	NIPDAU	Level-4-260C-72 HR	0 to 70	TAS5142	<a href="#">Samples</a>
TAS5142DKDR	ACTIVE	HSSOP	DKD	36	500	RoHS & Green	NIPDAU	Level-4-260C-72 HR	0 to 70	TAS5142	<a href="#">Samples</a>

(1) The marketing status values are defined as follows:

**ACTIVE:** Product device recommended for new designs.

**LIFEBUY:** TI has announced that the device will be discontinued, and a lifetime-buy period is in effect.

**NRND:** Not recommended for new designs. Device is in production to support existing customers, but TI does not recommend using this part in a new design.

**PREVIEW:** Device has been announced but is not in production. Samples may or may not be available.

**OBSELETE:** TI has discontinued the production of the device.

(2) **RoHS:** TI defines "RoHS" to mean semiconductor products that are compliant with the current EU RoHS requirements for all 10 RoHS substances, including the requirement that RoHS substance do not exceed 0.1% by weight in homogeneous materials. Where designed to be soldered at high temperatures, "RoHS" products are suitable for use in specified lead-free processes. TI may reference these types of products as "Pb-Free".

**RoHS Exempt:** TI defines "RoHS Exempt" to mean products that contain lead but are compliant with EU RoHS pursuant to a specific EU RoHS exemption.

**Green:** TI defines "Green" to mean the content of Chlorine (Cl) and Bromine (Br) based flame retardants meet JS709B low halogen requirements of <=1000ppm threshold. Antimony trioxide based flame retardants must also meet the <=1000ppm threshold requirement.

(3) MSL, Peak Temp. - The Moisture Sensitivity Level rating according to the JEDEC industry standard classifications, and peak solder temperature.

(4) There may be additional marking, which relates to the logo, the lot trace code information, or the environmental category on the device.

(5) Multiple Device Markings will be inside parentheses. Only one Device Marking contained in parentheses and separated by a "~" will appear on a device. If a line is indented then it is a continuation of the previous line and the two combined represent the entire Device Marking for that device.

(6) Lead finish/Ball material - Orderable Devices may have multiple material finish options. Finish options are separated by a vertical ruled line. Lead finish/Ball material values may wrap to two lines if the finish value exceeds the maximum column width.

**Important Information and Disclaimer:** The information provided on this page represents TI's knowledge and belief as of the date that it is provided. TI bases its knowledge and belief on information provided by third parties, and makes no representation or warranty as to the accuracy of such information. Efforts are underway to better integrate information from third parties. TI has taken and continues to take reasonable steps to provide representative and accurate information but may not have conducted destructive testing or chemical analysis on incoming materials and chemicals. TI and TI suppliers consider certain information to be proprietary, and thus CAS numbers and other limited information may not be available for release.

In no event shall TI's liability arising out of such information exceed the total purchase price of the TI part(s) at issue in this document sold by TI to Customer on an annual basis.



## TAPE AND REEL INFORMATION



### QUADRANT ASSIGNMENTS FOR PIN 1 ORIENTATION IN TAPE



\*All dimensions are nominal

Device	Package Type	Package Drawing	Pins	SPQ	Reel Diameter (mm)	Reel Width W1 (mm)	A0 (mm)	B0 (mm)	K0 (mm)	P1 (mm)	W (mm)	Pin1 Quadrant
TAS5142DDVR	HTSSOP	DDV	44	2000	330.0	24.4	8.6	15.6	1.8	12.0	24.0	Q1

TAPE AND REEL BOX DIMENSIONS



\*All dimensions are nominal

Device	Package Type	Package Drawing	Pins	SPQ	Length (mm)	Width (mm)	Height (mm)
TAS5142DDVR	HTSSOP	DDV	44	2000	350.0	350.0	43.0

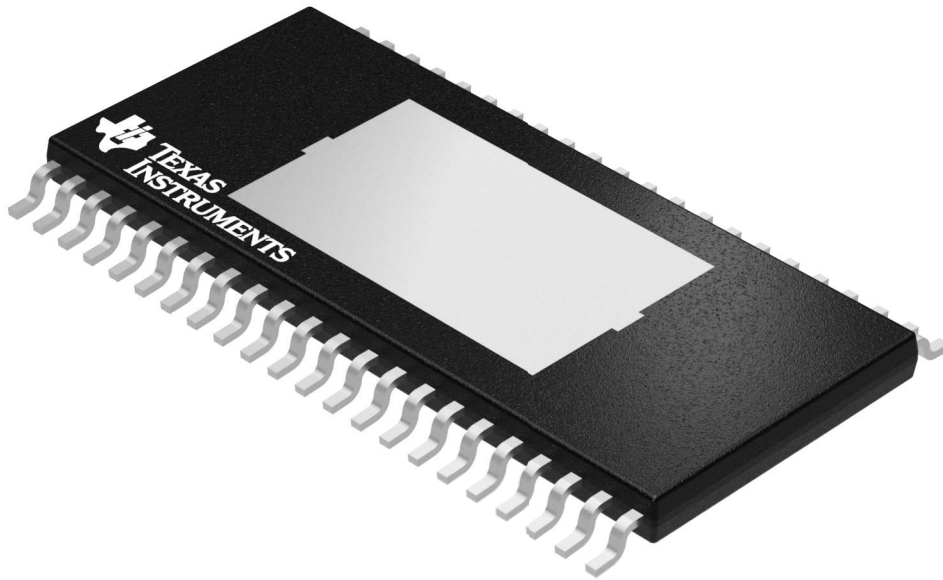

Images above are just a representation of the package family, actual package may vary.  
Refer to the product data sheet for package details.

# MECHANICAL DATA

DDV (R-PDSO-G44) PowerPAD™ PLASTIC SMALL OUTLINE PACKAGE (DIE DOWN)

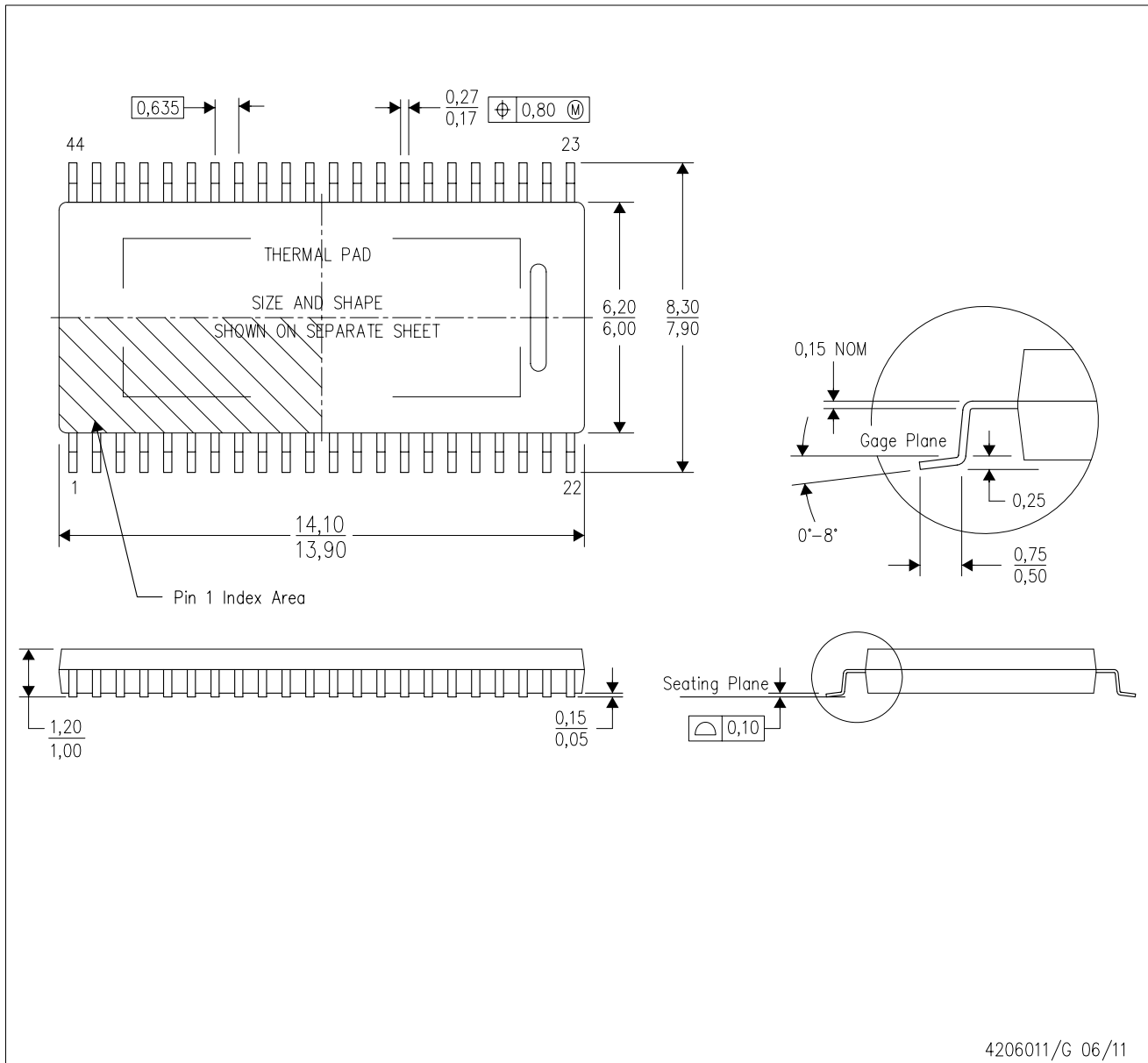

4206011/G 06/11

- NOTES:
- All linear dimensions are in millimeters. Dimensioning and tolerancing per ASME Y14.5M-1994.
  - This drawing is subject to change without notice.
  - Body dimensions do not include mold flash or protrusion not to exceed 0,15.
  - This package is designed to be attached directly to an external heatsink. Refer to Technical Brief, PowerPad Thermally Enhanced Package, Texas Instruments Literature No. SLMA002 for information regarding recommended board layout. This document is available at [www.ti.com](http://www.ti.com) <<http://www.ti.com>>. See the product data sheet for details regarding the exposed thermal pad dimensions.

PowerPAD is a trademark of Texas Instruments.

# THERMAL PAD MECHANICAL DATA

DDV (R-PDSO-G44)

PowerPAD™ SMALL OUTLINE PACKAGE

## THERMAL INFORMATION

This PowerPAD™ package incorporates an exposed thermal pad that is designed to be attached directly to an external heatsink. This design optimizes the heat transfer from the integrated circuit (IC).

For additional information on the PowerPAD package and how to take advantage of its heat dissipating abilities, refer to Technical Brief, PowerPAD Thermally Enhanced Package, Texas Instruments Literature No. SLMA002 and Application Brief, PowerPAD Made Easy, Texas Instruments Literature No. SLMA004. Both documents are available at [www.ti.com](http://www.ti.com).

The exposed thermal pad dimensions for this package are shown in the following illustration.

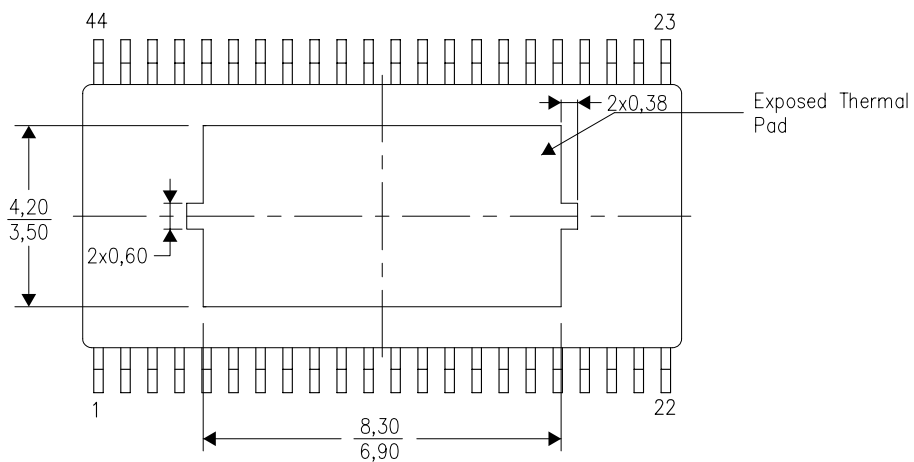

Top View

Exposed Thermal Pad Dimensions

4206975-2/D 07/11

NOTE: All linear dimensions are in millimeters

PowerPAD is a trademark of Texas Instruments

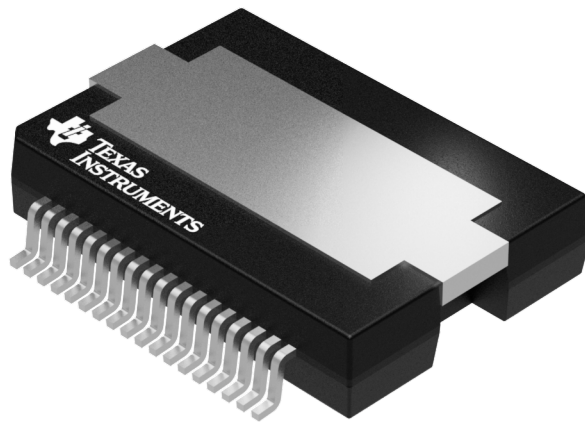

Images above are just a representation of the package family, actual package may vary.  
Refer to the product data sheet for package details.

DKD0036A

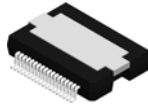

# PACKAGE OUTLINE

PowerPAD™ SSOP - 3.6 mm max height

PLASTIC SMALL OUTLINE

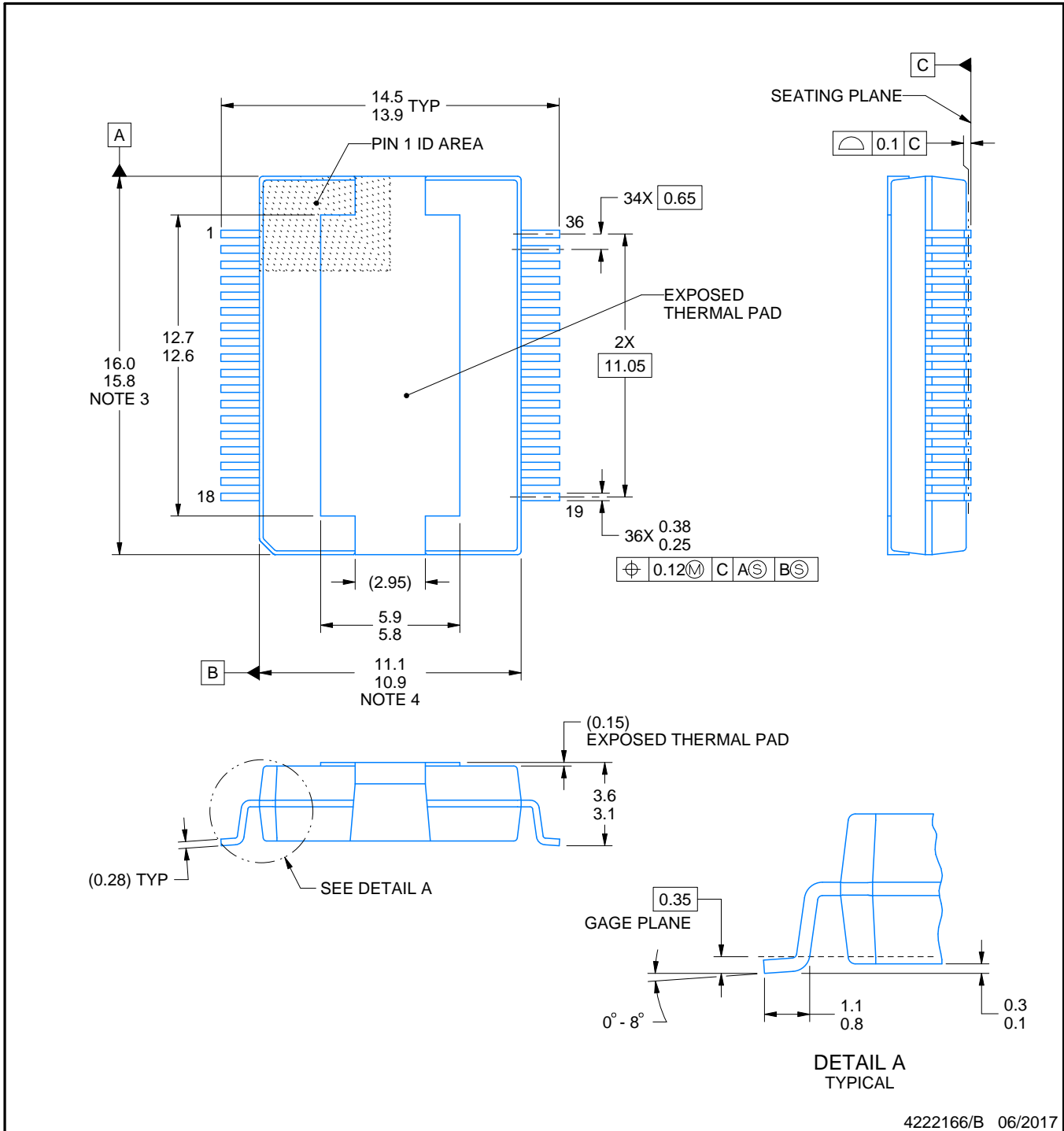

4222166/B 06/2017

NOTES:

PowerPAD is a trademark of Texas Instruments.

1. All linear dimensions are in millimeters. Any dimensions in parenthesis are for reference only. Dimensioning and tolerancing per ASME Y14.5M.
2. This drawing is subject to change without notice.
3. This dimension does not include mold flash, protrusions, or gate burrs. Mold flash, protrusions, or gate burrs shall not exceed 0.15 mm per side.
4. The exposed thermal pad is designed to be attached to an external heatsink.

# EXAMPLE BOARD LAYOUT

DKD0036A

PowerPAD™ SSOP - 3.6 mm max height

PLASTIC SMALL OUTLINE

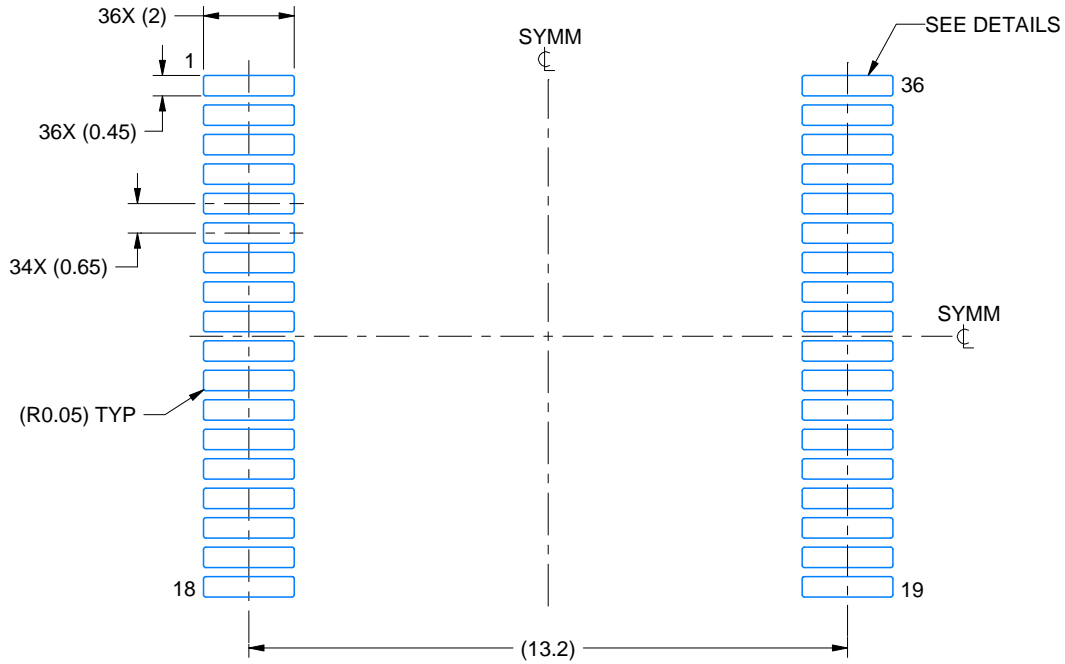

LAND PATTERN EXAMPLE  
EXPOSED METAL SHOWN  
SCALE:6X

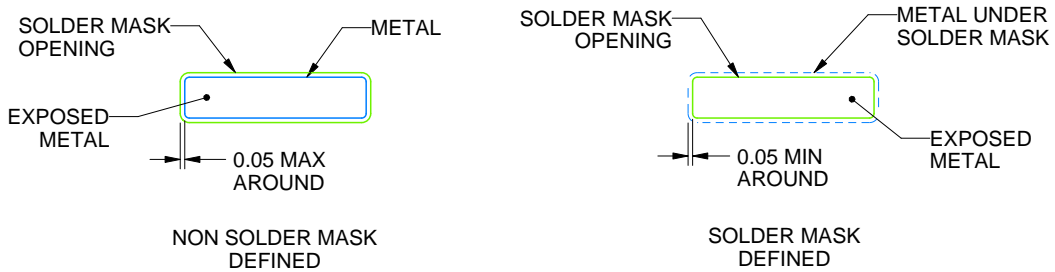

SOLDER MASK DETAILS  
NOT TO SCALE

4222166/B 06/2017

NOTES: (continued)

- 5. Publication IPC-7351 may have alternate designs.
- 6. Solder mask tolerances between and around signal pads can vary based on board fabrication site.



# EXAMPLE STENCIL DESIGN

DKD0036A

PowerPAD™ SSOP - 3.6 mm max height

PLASTIC SMALL OUTLINE

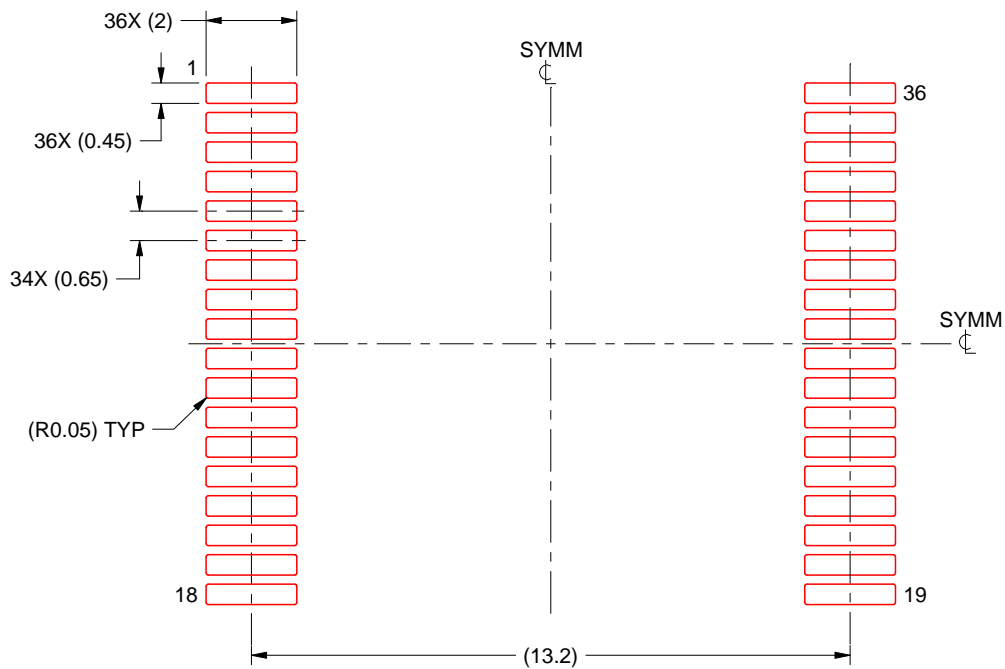

SOLDER PASTE EXAMPLE  
BASED ON 0.125 MM THICK STENCIL  
SCALE:6X

4222166/B 06/2017

NOTES: (continued)

7. Laser cutting apertures with trapezoidal walls and rounded corners may offer better paste release. IPC-7525 may have alternate design recommendations.
8. Board assembly site may have different recommendations for stencil design.

## IMPORTANT NOTICE AND DISCLAIMER

TI PROVIDES TECHNICAL AND RELIABILITY DATA (INCLUDING DATASHEETS), DESIGN RESOURCES (INCLUDING REFERENCE DESIGNS), APPLICATION OR OTHER DESIGN ADVICE, WEB TOOLS, SAFETY INFORMATION, AND OTHER RESOURCES "AS IS" AND WITH ALL FAULTS, AND DISCLAIMS ALL WARRANTIES, EXPRESS AND IMPLIED, INCLUDING WITHOUT LIMITATION ANY IMPLIED WARRANTIES OF MERCHANTABILITY, FITNESS FOR A PARTICULAR PURPOSE OR NON-INFRINGEMENT OF THIRD PARTY INTELLECTUAL PROPERTY RIGHTS.

These resources are intended for skilled developers designing with TI products. You are solely responsible for (1) selecting the appropriate TI products for your application, (2) designing, validating and testing your application, and (3) ensuring your application meets applicable standards, and any other safety, security, or other requirements. These resources are subject to change without notice. TI grants you permission to use these resources only for development of an application that uses the TI products described in the resource. Other reproduction and display of these resources is prohibited. No license is granted to any other TI intellectual property right or to any third party intellectual property right. TI disclaims responsibility for, and you will fully indemnify TI and its representatives against, any claims, damages, costs, losses, and liabilities arising out of your use of these resources.

TI's products are provided subject to TI's Terms of Sale (<https://www.ti.com/legal/termsofsale.html>) or other applicable terms available either on [ti.com](https://www.ti.com) or provided in conjunction with such TI products. TI's provision of these resources does not expand or otherwise alter TI's applicable warranties or warranty disclaimers for TI products.

Mailing Address: Texas Instruments, Post Office Box 655303, Dallas, Texas 75265  
Copyright © 2021, Texas Instruments Incorporated