

THIS DOCUMENT IS THE PROPERTY OF
KEYSTONE ELECTRONICS CORP. AND
SHALL NOT BE REPRODUCED, DISTRIBUTED
OR USED AS A BASIS FOR MANUFACTURE
WITHOUT PRIOR WRITTEN PERMISSION
FROM KEYSTONE ELECTRONICS CORP.

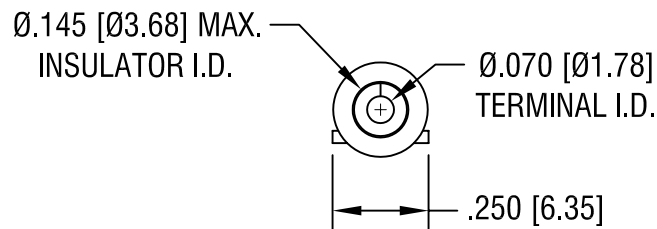
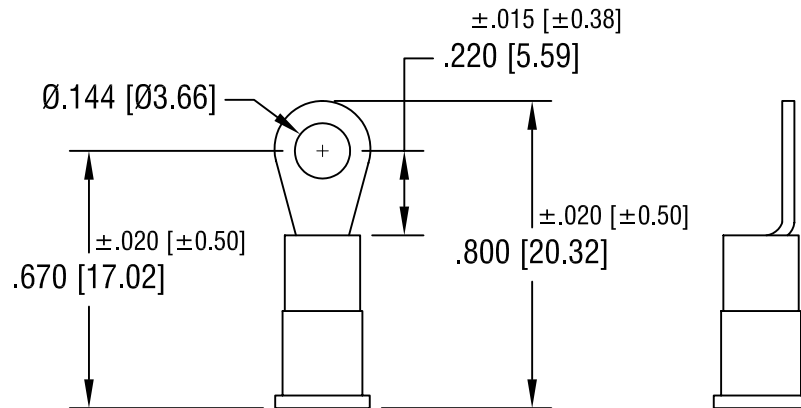

NOTE:

1. TERMINAL: $.030 [0.76]$ THK COPPER, TIN PLATE
INSULATOR: VINYL, RED
2. ACCOMMODATES WIRE RANGE 22/18 AWG

KEYSTONE ELECTRONICS CORP.

ASTORIA, N.Y. 11105-2017

PART NAME

INSULATED RING TONGUE TERMINAL

MATERIAL

AS NOTED

FINISH

AS NOTED

DRN BY

BOONE

DATE

10.19.07

APP'D

LN

SCALE

2X

TOLERANCES

INCH [MM]

DECIMAL $\pm .005 [\pm 0.15]$

ANGULAR $\pm 1^\circ$

UNLESS OTHERWISE SPECIFIED

CODE

C/M

DWG NO.

8209

DATE

DESCRIPTION

REV.

Mouser Electronics

Authorized Distributor

Click to View Pricing, Inventory, Delivery & Lifecycle Information:

[Keystone Electronics:](#)

[8209](#)