

# 50mm Size Ring Type EC50A Series

| Photo | Dimensions | Mounting Hole Dimensions | Output Wave | Sliding Noise |  
 | Packing Specifications | Soldering Conditions |

PRINT

Part number		<b>EC50A0920404</b>	
Actuator length		14.5mm	
Detent torque		40±14mN · m	
Number of detent		18	
Number of pulse		9	
Operating temperature range		-40°C to +85°C	
Electrical performance	Ratings	1mA 5V DC	
	Output signal	Two phase A and B	
	Insulation resistance	10MΩ min. 250V DC	
	Voltage proof	50V AC for 1 minute or 60V AC for 2s	
Mechanical performance	Actuator strength	Pushing direction	100N
		Pulling direction	50N
Durability	Operating life	40,000 cycles	
Minimum order unit (pcs.)	Japan	200	
	Export	200	

3D CAD (STEP) [↓](#)

Certificate of Compliance to RoHS regulations [↓](#)

## Photo

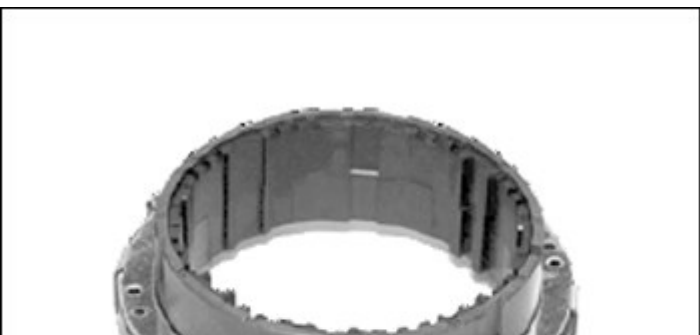



## Dimensions

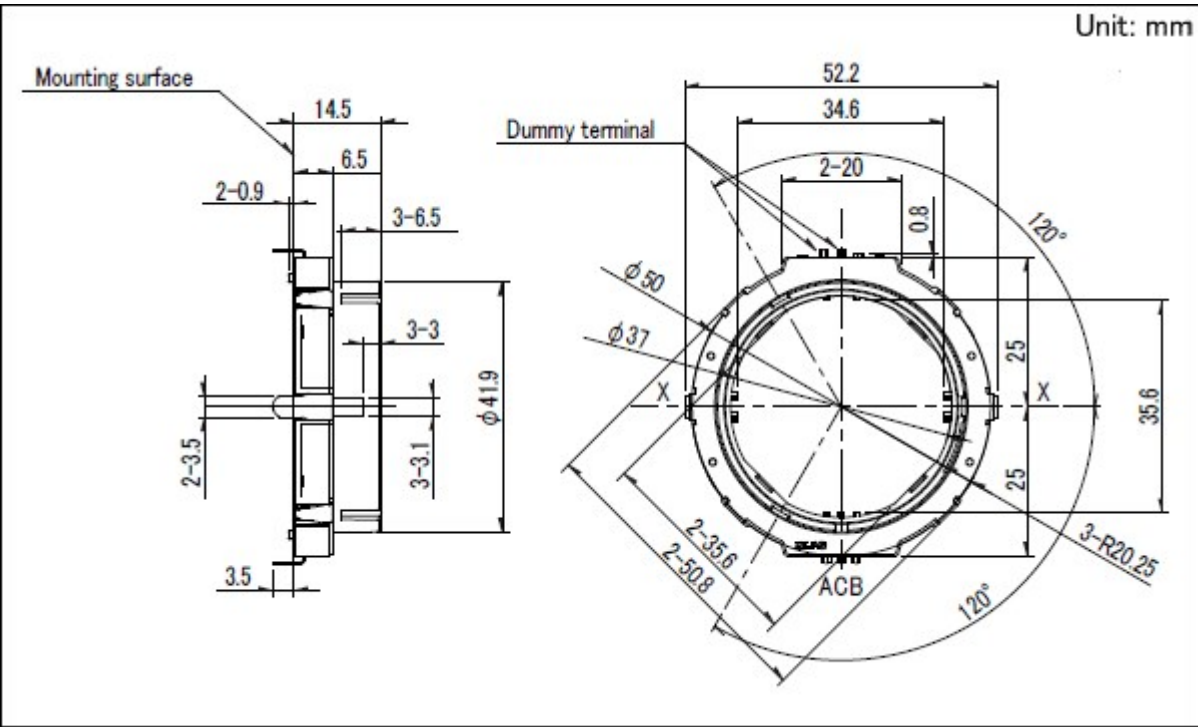

## Mounting Hole Dimensions

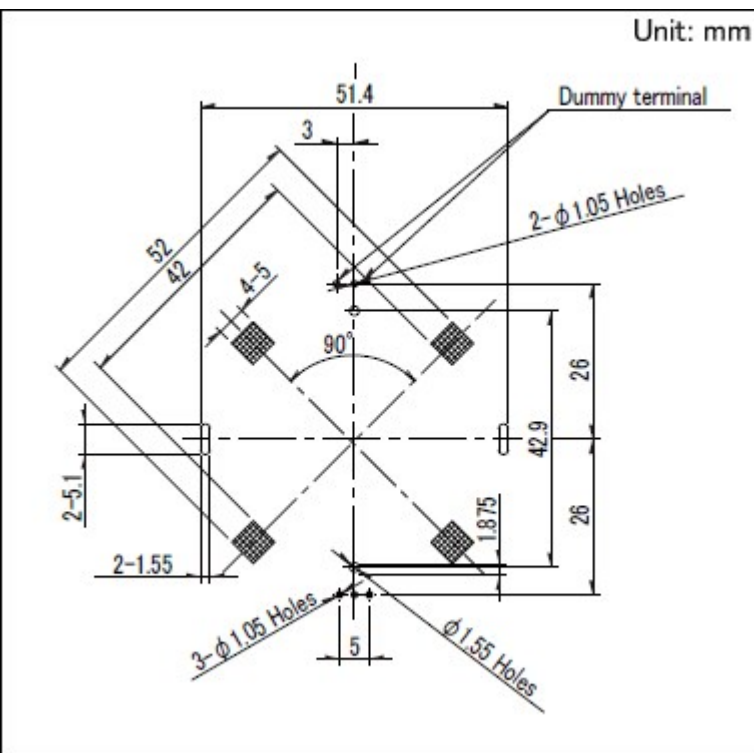

Viewed from mounting side  
Wiring prohibited on hatched area

## Output Wave

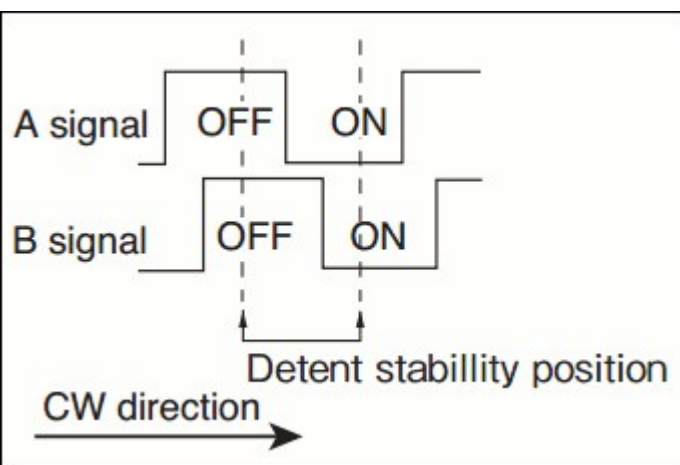

## Sliding Noise

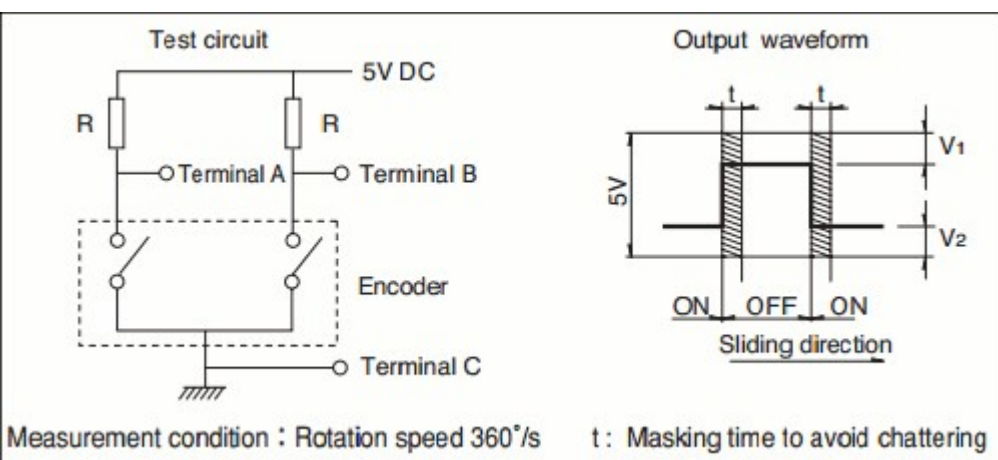

V<sub>1</sub>=V<sub>2</sub>=2.5V max.

At R = 5kΩ Chattering: 5ms max. Bounce: 5ms max.

## Packing Specifications

### Tray

Number of packages 1 case / Japan 200  
(pcs.)

1 case / export 400  
packing

Export package measurements (mm) 360×540×290

## Soldering Conditions

### Reference for Dip Soldering

Preheating Soldering surfacetemperature 100°C max.

Heating time 2 min. max.

Dip soldering Soldering temperature 260±5°C

Soldering time 5±1s

No. of solders

2 time max.

---

### Reference for Hand Soldering

---

Tip temperature

350°C max.

---

Soldering time

3s max.

---

No. of solders

1 time

---

Notes are common to this series/models.

1. This site catalog shows only outline specifications. When using the products, please obtain formal specifications for supply.
2. Please place purchase orders per minimum order unit (integer).
3. This products can be used in vehicles.  
Although these products are designed to perform over a wide operating temperature range, please ensure that you receive and read the formal delivery specifications before use.

### Inquiries about Products

 [Inquiry](#)

# Mouser Electronics

Authorized Distributor

Click to View Pricing, Inventory, Delivery & Lifecycle Information:

[Alps Alpine:](#)

[EC50A0920404](#)