

POSITIVE VOLTAGE REGULATORS

- OUTPUT CURRENT TO 0.5A
- OUTPUT VOLTAGES OF 5; 6; 8; 9; 12; 15; 18; 20; 24V
- THERMAL OVERLOAD PROTECTION
- SHORT CIRCUIT PROTECTION
- OUTPUT TRANSITION SOA PROTECTION

DESCRIPTION

The L78M00 series of three-terminal positive regulators is available in TO-220, TO-220FP, DPAK and IPAK packages and with several fixed output voltages, making it useful in a wide range of applications. These regulators can provide local on-card regulation, eliminating the distribution problems associated with single point regulation. Each type employs internal current limiting, thermal shut-down and safe area protection, making it essentially indestructible. If adequate heat sinking is provided, they can deliver over 0.5A output current. Although designed primarily as fixed voltage regulators, these devices can be

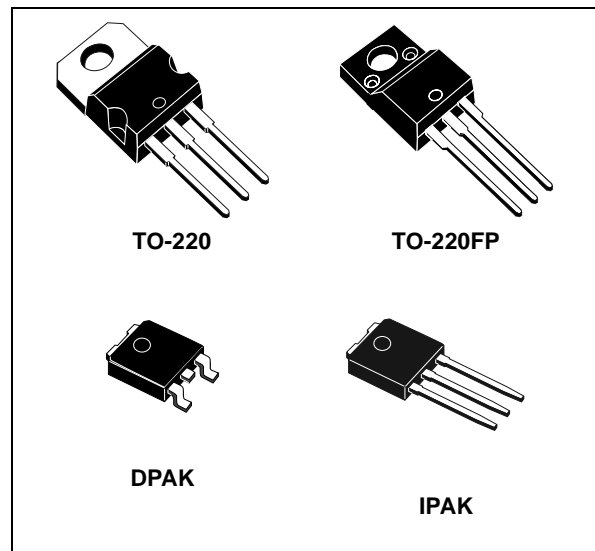

used with external components to obtain adjustable voltage and currents.

SCHEMATIC DIAGRAM

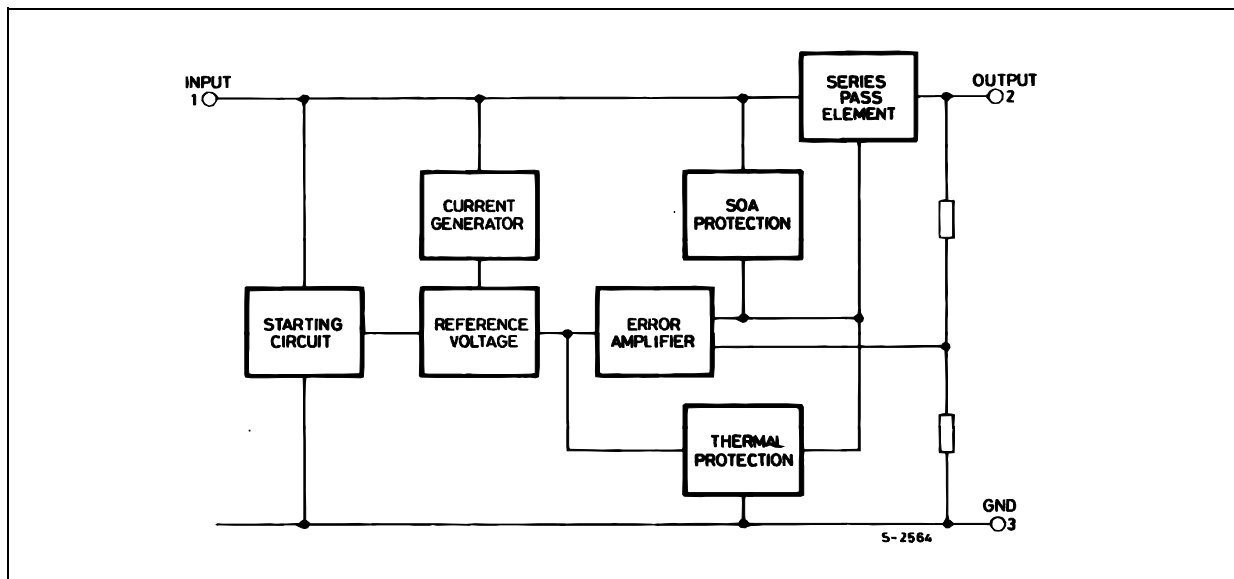

L78M00 SERIES

ABSOLUTE MAXIMUM RATINGS

| Symbol | Parameter | Value | Unit |
|-----------|---|--------------------|--------|
| V_I | DC Input Voltage (for $V_O=5$ to 18V) (for $V_O=20, 24V$) | 35 40 | V V |
| I_O | Output Current | Internally Limited | mA |
| P_D | Power Dissipation | Internally Limited | mW |
| T_{stg} | Storage Temperature Range | -65 to +150 | °C |
| T_{op} | Operating Junction Temperature Range | 0 to +150 | °C |

Absolute Maximum Ratings are those values beyond which damage to the device may occur. Functional operation under these condition is not implied.

THERMAL DATA

| Symbol | Parameter | TO-220 | TO-220FP | DPAK | IPAK | Unit |
|----------------|-------------------------------------|--------|----------|------|------|------|
| $R_{thj-case}$ | Thermal Resistance Junction-case | 3 | 5 | 8 | | °C/W |
| $R_{thj-amb}$ | Thermal Resistance Junction-ambient | 50 | 60 | 100 | | °C/W |

SHEMATIC DIAGRAM

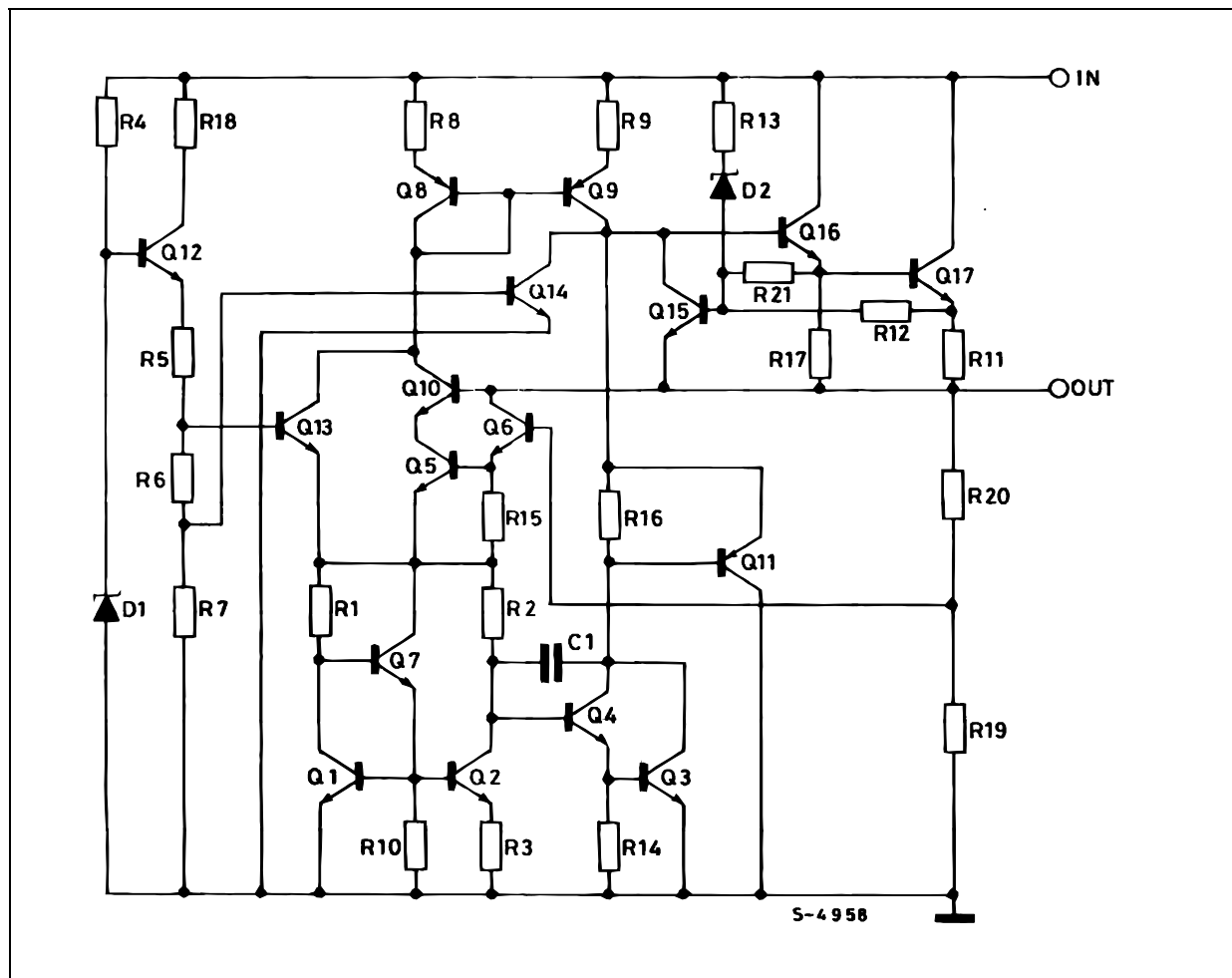

CONNECTION DIAGRAM (top view)

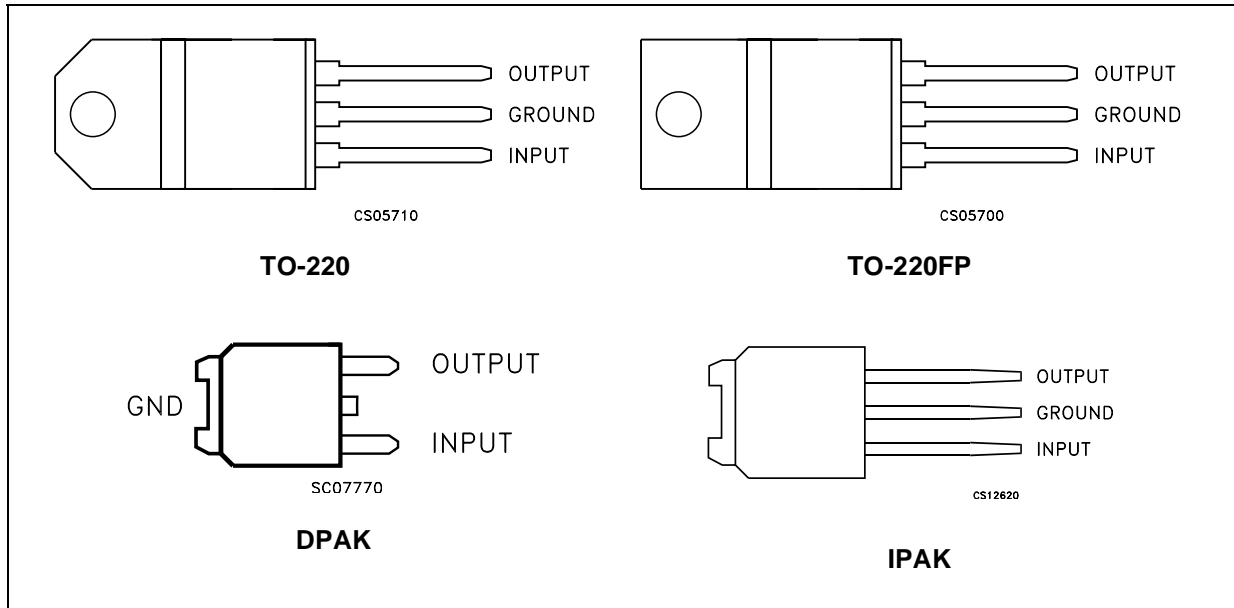

ORDERING CODES

| TYPE | TO-220 | TO-220FP | DPAK (*) | IPAK | OUTPUT VOLTAGE |
|--------|----------|----------|-----------|-------------|----------------|
| L78M05 | L78M05CV | L78M05CP | L78M05CDT | L78M05CDT-1 | 5 V |
| L78M06 | L78M06CV | L78M06CP | L78M06CDT | L78M06CDT-1 | 6 V |
| L78M08 | L78M08CV | L78M08CP | L78M08CDT | L78M08CDT-1 | 8 V |
| L78M09 | L78M09CV | L78M09CP | L78M09CDT | L78M09CDT-1 | 9 V |
| L78M10 | L78M10CV | L78M10CP | L78M10CDT | L78M10CDT-1 | 10 V |
| L78M12 | L78M12CV | L78M12CP | L78M12CDT | L78M12CDT-1 | 12 V |
| L78M15 | L78M15CV | L78M15CP | L78M15CDT | L78M15CDT-1 | 15 V |
| L78M18 | L78M18CV | L78M18CP | L78M18CDT | L78M18CDT-1 | 18 V |
| L78M20 | L78M20CV | L78M20CP | L78M20CDT | L78M20CDT-1 | 20 V |
| L78M24 | L78M24CV | L78M24CP | L78M24CDT | L78M24CDT-1 | 24 V |

(*) Available in Tape & Reel with the suffix "-TR".

APPLICATION CIRCUITS

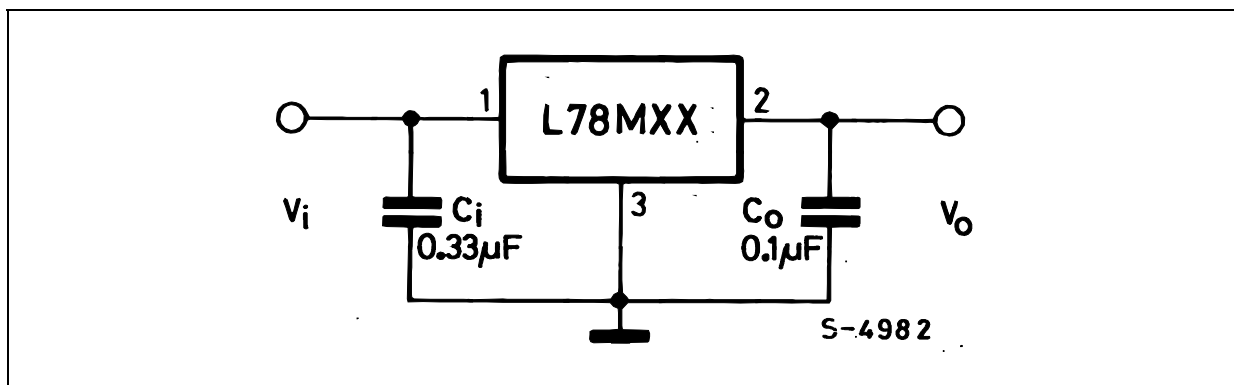

L78M00 SERIES

TEST CIRCUITS

Figure 1 : DC Parameter

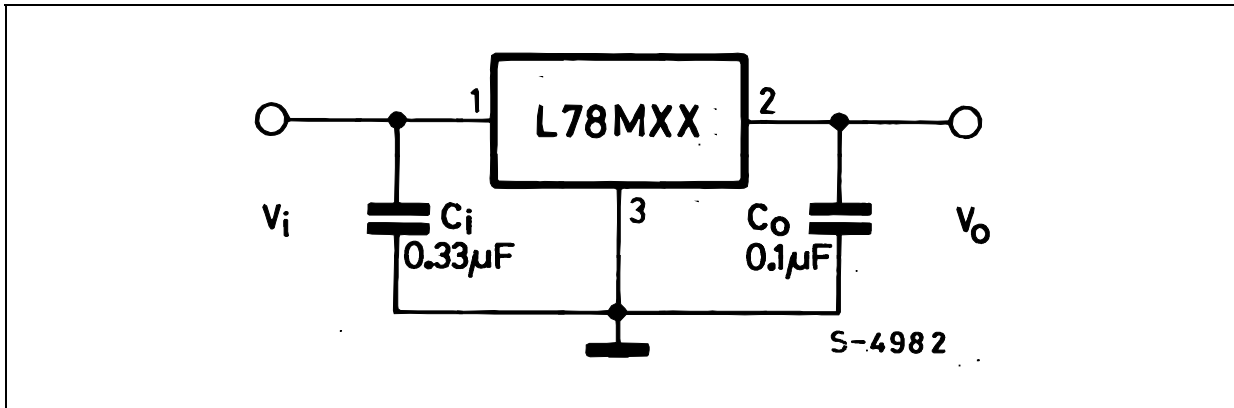

Figure 2 : Load Regulation

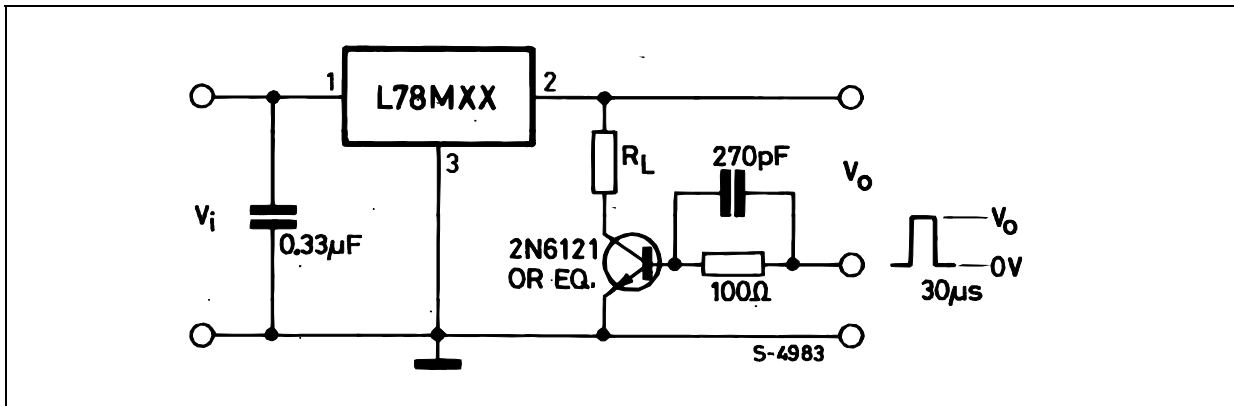
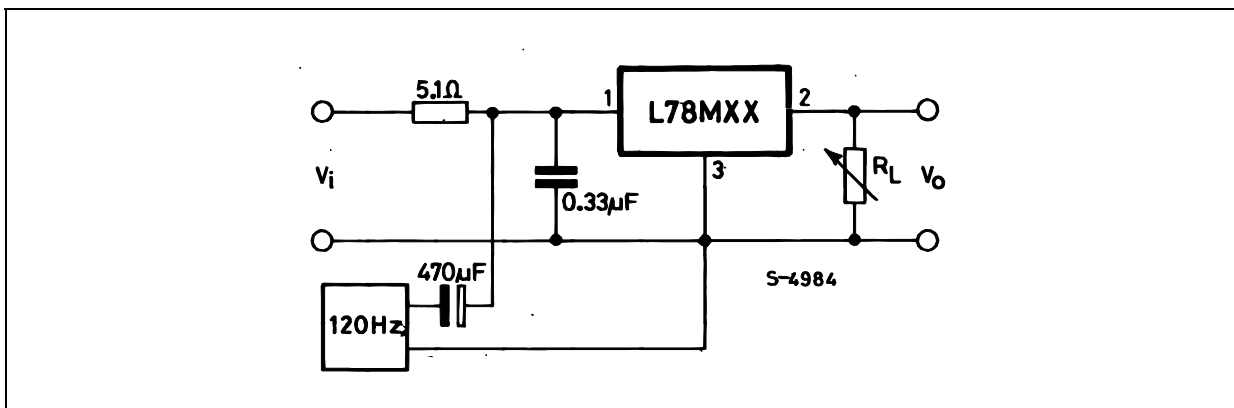

Figure 3 : Ripple Rejection



ELECTRICAL CHARACTERISTICS OF L78M05C (refer to the test circuits, $T_J = 25^\circ\text{C}$, $V_I = 10\text{V}$, $I_O = 350\text{ mA}$, $C_I = 0.33\ \mu\text{F}$, $C_O = 0.1\ \mu\text{F}$ unless otherwise specified).

| Symbol | Parameter | Test Conditions | Min. | Typ. | Max. | Unit |
|-----------------------|--------------------------|--|------|------|------|---------------|
| V_O | Output Voltage | | 4.8 | 5 | 5.2 | V |
| V_O | Output Voltage | $I_O = 5\text{ to }350\text{ mA}$ $V_I = 7\text{ to }20\text{ V}$ | 4.75 | 5 | 5.25 | V |
| ΔV_O | Line Regulation | $V_I = 7\text{ to }25\text{ V}$ $I_O = 200\text{ mA}$ | | | 100 | mV |
| | | $V_I = 8\text{ to }25\text{ V}$ $I_O = 200\text{ mA}$ | | | 50 | |
| ΔV_O | Load Regulation | $I_O = 5\text{ to }500\text{ mA}$ $T_J = 25^\circ\text{C}$ | | | 100 | mV |
| | | $I_O = 5\text{ to }200\text{ mA}$ $T_J = 25^\circ\text{C}$ | | | 50 | |
| I_d | Quiescent Current | | | | 6 | mA |
| ΔI_d | Quiescent Current Change | $I_O = 5\text{ to }350\text{ mA}$ | | | 0.5 | mA |
| | | $I_O = 200\text{ mA}$ $V_I = 8\text{ to }25\text{ V}$ | | | 0.8 | |
| $\Delta V_O/\Delta T$ | Output Voltage Drift | $I_O = 5\text{ mA}$ $T_J = 0\text{ to }125^\circ\text{C}$ | | -0.5 | | mV/°C |
| SVR | Supply Voltage Rejection | $V_I = 8\text{ to }18\text{ V}$ $f = 120\text{Hz}$ $I_O = 300\text{mA}$ | 62 | | | dB |
| eN | Output Noise Voltage | $B = 10\text{Hz to }100\text{KHz}$ | | 40 | | μV |
| V_d | Dropout Voltage | | | 2 | | V |
| I_{sc} | Short Circuit Current | $V_I = 35\text{ V}$ | | 300 | | mA |

ELECTRICAL CHARACTERISTICS OF L78M06C (refer to the test circuits, $T_J = 25^\circ\text{C}$, $V_I = 11\text{V}$, $I_O = 350\text{ mA}$, $C_I = 0.33\ \mu\text{F}$, $C_O = 0.1\ \mu\text{F}$ unless otherwise specified).

| Symbol | Parameter | Test Conditions | Min. | Typ. | Max. | Unit |
|-----------------------|--------------------------|--|------|------|------|---------------|
| V_O | Output Voltage | | 5.75 | 6 | 6.25 | V |
| V_O | Output Voltage | $I_O = 5\text{ to }350\text{ mA}$ $V_I = 8\text{ to }21\text{ V}$ | 5.7 | 6 | 6.3 | V |
| ΔV_O | Line Regulation | $V_I = 8\text{ to }25\text{ V}$ $I_O = 200\text{ mA}$ | | | 100 | mV |
| | | $V_I = 9\text{ to }25\text{ V}$ $I_O = 200\text{ mA}$ | | | 50 | |
| ΔV_O | Load Regulation | $I_O = 5\text{ to }500\text{ mA}$ $T_J = 25^\circ\text{C}$ | | | 120 | mV |
| | | $I_O = 5\text{ to }200\text{ mA}$ $T_J = 25^\circ\text{C}$ | | | 60 | |
| I_d | Quiescent Current | | | | 6 | mA |
| ΔI_d | Quiescent Current Change | $I_O = 5\text{ to }350\text{ mA}$ | | | 0.5 | mA |
| | | $I_O = 200\text{ mA}$ $V_I = 9\text{ to }25\text{ V}$ | | | 0.8 | |
| $\Delta V_O/\Delta T$ | Output Voltage Drift | $I_O = 5\text{ mA}$ $T_J = 0\text{ to }125^\circ\text{C}$ | | -0.5 | | mV/°C |
| SVR | Supply Voltage Rejection | $V_I = 9\text{ to }19\text{ V}$ $f = 120\text{Hz}$ $I_O = 300\text{mA}$ | 59 | | | dB |
| eN | Output Noise Voltage | $B = 10\text{Hz to }100\text{KHz}$ | | 45 | | μV |
| V_d | Dropout Voltage | | | 2 | | V |
| I_{sc} | Short Circuit Current | $V_I = 35\text{ V}$ | | 270 | | mA |

L78M00 SERIES

ELECTRICAL CHARACTERISTICS OF L78M08C (refer to the test circuits, $T_J = 25^\circ\text{C}$, $V_I = 14\text{V}$, $I_O = 350\text{ mA}$, $C_I = 0.33\text{ }\mu\text{F}$, $C_O = 0.1\text{ }\mu\text{F}$ unless otherwise specified).

| Symbol | Parameter | Test Conditions | Min. | Typ. | Max. | Unit |
|-----------------------|--------------------------|---|------|------|------|----------------------|
| V_O | Output Voltage | | 7.7 | 8 | 8.3 | V |
| V_O | Output Voltage | $I_O = 5\text{ to }350\text{ mA}$ $V_I = 10.5\text{ to }23\text{ V}$ | 7.6 | 8 | 8.4 | V |
| ΔV_O | Line Regulation | $V_I = 10.5\text{ to }25\text{ V}$ $I_O = 200\text{ mA}$ | | | 100 | mV |
| | | $V_I = 11\text{ to }25\text{ V}$ $I_O = 200\text{ mA}$ | | | 50 | |
| ΔV_O | Load Regulation | $I_O = 5\text{ to }500\text{ mA}$ $T_J = 25^\circ\text{C}$ | | | 160 | mV |
| | | $I_O = 5\text{ to }200\text{ mA}$ $T_J = 25^\circ\text{C}$ | | | 80 | |
| I_d | Quiescent Current | | | | 6 | mA |
| ΔI_d | Quiescent Current Change | $I_O = 5\text{ to }350\text{ mA}$ | | | 0.5 | mA |
| | | $I_O = 200\text{ mA}$ $V_I = 10.5\text{ to }25\text{ V}$ | | | 0.8 | |
| $\Delta V_O/\Delta T$ | Output Voltage Drift | $I_O = 5\text{ mA}$ $T_J = 0\text{ to }125^\circ\text{C}$ | | -0.5 | | mV/ $^\circ\text{C}$ |
| SVR | Supply Voltage Rejection | $V_I = 11.5\text{ to }21.5\text{ V}$ $f = 120\text{ Hz}$ $I_O = 300\text{ mA}$ | 56 | | | dB |
| eN | Output Noise Voltage | $B = 10\text{ Hz to }100\text{ KHz}$ | | 52 | | μV |
| V_d | Dropout Voltage | | | 2 | | V |
| I_{sc} | Short Circuit Current | $V_I = 35\text{ V}$ | | 250 | | mA |

ELECTRICAL CHARACTERISTICS OF L78M09C (refer to the test circuits, $T_J = 25^\circ\text{C}$, $V_I = 15\text{V}$, $I_O = 350\text{ mA}$, $C_I = 0.33\text{ }\mu\text{F}$, $C_O = 0.1\text{ }\mu\text{F}$ unless otherwise specified).

| Symbol | Parameter | Test Conditions | Min. | Typ. | Max. | Unit |
|-----------------------|--------------------------|---|------|------|------|----------------------|
| V_O | Output Voltage | | 8.65 | 9 | 9.35 | V |
| V_O | Output Voltage | $I_O = 5\text{ to }350\text{ mA}$ $V_I = 11.5\text{ to }24\text{ V}$ | 8.55 | 9 | 9.45 | V |
| ΔV_O | Line Regulation | $V_I = 11.5\text{ to }25\text{ V}$ $I_O = 200\text{ mA}$ | | | 100 | mV |
| | | $V_I = 12\text{ to }25\text{ V}$ $I_O = 200\text{ mA}$ | | | 50 | |
| ΔV_O | Load Regulation | $I_O = 5\text{ to }500\text{ mA}$ $T_J = 25^\circ\text{C}$ | | | 180 | mV |
| | | $I_O = 5\text{ to }200\text{ mA}$ $T_J = 25^\circ\text{C}$ | | | 90 | |
| I_d | Quiescent Current | | | | 6 | mA |
| ΔI_d | Quiescent Current Change | $I_O = 5\text{ to }350\text{ mA}$ | | | 0.5 | mA |
| | | $I_O = 200\text{ mA}$ $V_I = 11.5\text{ to }25\text{ V}$ | | | 0.8 | |
| $\Delta V_O/\Delta T$ | Output Voltage Drift | $I_O = 5\text{ mA}$ $T_J = 0\text{ to }125^\circ\text{C}$ | | -0.5 | | mV/ $^\circ\text{C}$ |
| SVR | Supply Voltage Rejection | $V_I = 12.5\text{ to }23\text{ V}$ $f = 120\text{ Hz}$ $I_O = 300\text{ mA}$ | 56 | | | dB |
| eN | Output Noise Voltage | $B = 10\text{ Hz to }100\text{ KHz}$ | | 58 | | μV |
| V_d | Dropout Voltage | | | 2 | | V |
| I_{sc} | Short Circuit Current | $V_I = 35\text{ V}$ | | 250 | | mA |

ELECTRICAL CHARACTERISTICS OF L78M10C (refer to the test circuits, $T_J = 25^\circ\text{C}$, $V_I = 16\text{V}$, $I_O = 350\text{ mA}$, $C_I = 0.33\text{ }\mu\text{F}$, $C_O = 0.1\text{ }\mu\text{F}$ unless otherwise specified).

| Symbol | Parameter | Test Conditions | Min. | Typ. | Max. | Unit |
|-----------------------|--------------------------|---|------|------|------|----------------------|
| V_O | Output Voltage | | 9.6 | 10 | 10.4 | V |
| V_O | Output Voltage | $I_O = 5\text{ to }350\text{ mA}$ $V_I = 12.5\text{ to }25\text{ V}$ | 9.5 | 10 | 10.5 | V |
| ΔV_O | Line Regulation | $V_I = 12.5\text{ to }30\text{ V}$ $I_O = 200\text{ mA}$ | | | 100 | mV |
| | | $V_I = 13\text{ to }30\text{ V}$ $I_O = 200\text{ mA}$ | | | 50 | |
| ΔV_O | Load Regulation | $I_O = 5\text{ to }500\text{ mA}$ $T_J = 25^\circ\text{C}$ | | | 200 | mV |
| | | $I_O = 5\text{ to }200\text{ mA}$ $T_J = 25^\circ\text{C}$ | | | 100 | |
| I_d | Quiescent Current | | | | 6 | mA |
| ΔI_d | Quiescent Current Change | $I_O = 5\text{ to }350\text{ mA}$ | | | 0.5 | mA |
| | | $I_O = 200\text{ mA}$ $V_I = 12.5\text{ to }30\text{ V}$ | | | 0.8 | |
| $\Delta V_O/\Delta T$ | Output Voltage Drift | $I_O = 5\text{ mA}$ $T_J = 0\text{ to }125^\circ\text{C}$ | | -0.5 | | mV/ $^\circ\text{C}$ |
| SVR | Supply Voltage Rejection | $V_I = 13.5\text{ to }24\text{ V}$ $f = 120\text{ Hz}$ $I_O = 300\text{ mA}$ | 56 | | | dB |
| eN | Output Noise Voltage | $B = 10\text{ Hz to }100\text{ KHz}$ | | 64 | | μV |
| V_d | Dropout Voltage | | | 2 | | V |
| I_{sc} | Short Circuit Current | $V_I = 35\text{ V}$ | | 245 | | mA |

ELECTRICAL CHARACTERISTICS OF L78M12C (refer to the test circuits, $T_J = 25^\circ\text{C}$, $V_I = 19\text{V}$, $I_O = 350\text{ mA}$, $C_I = 0.33\text{ }\mu\text{F}$, $C_O = 0.1\text{ }\mu\text{F}$ unless otherwise specified).

| Symbol | Parameter | Test Conditions | Min. | Typ. | Max. | Unit |
|-----------------------|--------------------------|---|------|------|------|----------------------|
| V_O | Output Voltage | | 11.5 | 12 | 12.5 | V |
| V_O | Output Voltage | $I_O = 5\text{ to }350\text{ mA}$ $V_I = 14.5\text{ to }27\text{ V}$ | 11.4 | 12 | 12.6 | V |
| ΔV_O | Line Regulation | $V_I = 14.5\text{ to }30\text{ V}$ $I_O = 200\text{ mA}$ | | | 100 | mV |
| | | $V_I = 16\text{ to }30\text{ V}$ $I_O = 200\text{ mA}$ | | | 50 | |
| ΔV_O | Load Regulation | $I_O = 5\text{ to }500\text{ mA}$ $T_J = 25^\circ\text{C}$ | | | 240 | mV |
| | | $I_O = 5\text{ to }200\text{ mA}$ $T_J = 25^\circ\text{C}$ | | | 120 | |
| I_d | Quiescent Current | | | | 6 | mA |
| ΔI_d | Quiescent Current Change | $I_O = 5\text{ to }350\text{ mA}$ | | | 0.5 | mA |
| | | $I_O = 200\text{ mA}$ $V_I = 14.5\text{ to }30\text{ V}$ | | | 0.8 | |
| $\Delta V_O/\Delta T$ | Output Voltage Drift | $I_O = 5\text{ mA}$ $T_J = 0\text{ to }125^\circ\text{C}$ | | -1 | | mV/ $^\circ\text{C}$ |
| SVR | Supply Voltage Rejection | $V_I = 15\text{ to }25\text{ V}$ $f = 120\text{ Hz}$ $I_O = 300\text{ mA}$ | 55 | | | dB |
| eN | Output Noise Voltage | $B = 10\text{ Hz to }100\text{ KHz}$ | | 75 | | μV |
| V_d | Dropout Voltage | | | 2 | | V |
| I_{sc} | Short Circuit Current | $V_I = 35\text{ V}$ | | 240 | | mA |

L78M00 SERIES

ELECTRICAL CHARACTERISTICS OF L78M15C (refer to the test circuits, $T_J = 25^\circ\text{C}$, $V_I = 23\text{V}$, $I_O = 350\text{ mA}$, $C_I = 0.33\text{ }\mu\text{F}$, $C_O = 0.1\text{ }\mu\text{F}$ unless otherwise specified).

| Symbol | Parameter | Test Conditions | Min. | Typ. | Max. | Unit |
|-----------------------|--------------------------|---|-------|------|-------|----------------------|
| V_O | Output Voltage | | 14.4 | 15 | 15.6 | V |
| V_O | Output Voltage | $I_O = 5\text{ to }350\text{ mA}$ $V_I = 17.5\text{ to }30\text{ V}$ | 14.25 | 15 | 15.75 | V |
| ΔV_O | Line Regulation | $V_I = 17.5\text{ to }30\text{ V}$ $I_O = 200\text{ mA}$ | | | 100 | mV |
| | | $V_I = 20\text{ to }30\text{ V}$ $I_O = 200\text{ mA}$ | | | 50 | |
| ΔV_O | Load Regulation | $I_O = 5\text{ to }500\text{ mA}$ $T_J = 25^\circ\text{C}$ | | | 300 | mV |
| | | $I_O = 5\text{ to }200\text{ mA}$ $T_J = 25^\circ\text{C}$ | | | 150 | |
| I_d | Quiescent Current | | | | 6 | mA |
| ΔI_d | Quiescent Current Change | $I_O = 5\text{ to }350\text{ mA}$ | | | 0.5 | mA |
| | | $I_O = 200\text{ mA}$ $V_I = 17.5\text{ to }30\text{ V}$ | | | 0.8 | |
| $\Delta V_O/\Delta T$ | Output Voltage Drift | $I_O = 5\text{ mA}$ $T_J = 0\text{ to }125^\circ\text{C}$ | | -1 | | mV/ $^\circ\text{C}$ |
| SVR | Supply Voltage Rejection | $V_I = 18.5\text{ to }28.5\text{ V}$ $f = 120\text{ Hz}$ $I_O = 300\text{ mA}$ | 54 | | | dB |
| eN | Output Noise Voltage | $B = 10\text{ Hz to }100\text{ KHz}$ | | 90 | | μV |
| V_d | Dropout Voltage | | | 2 | | V |
| I_{sc} | Short Circuit Current | $V_I = 35\text{ V}$ | | 240 | | mA |

ELECTRICAL CHARACTERISTICS OF L78M18C (refer to the test circuits, $T_J = 25^\circ\text{C}$, $V_I = 26\text{V}$, $I_O = 350\text{ mA}$, $C_I = 0.33\text{ }\mu\text{F}$, $C_O = 0.1\text{ }\mu\text{F}$ unless otherwise specified).

| Symbol | Parameter | Test Conditions | Min. | Typ. | Max. | Unit |
|-----------------------|--------------------------|---|------|------|------|----------------------|
| V_O | Output Voltage | | 17.3 | 18 | 18.7 | V |
| V_O | Output Voltage | $I_O = 5\text{ to }350\text{ mA}$ $V_I = 20.5\text{ to }33\text{ V}$ | 17.1 | 18 | 18.9 | V |
| ΔV_O | Line Regulation | $V_I = 21\text{ to }33\text{ V}$ $I_O = 200\text{ mA}$ | | | 100 | mV |
| | | $V_I = 24\text{ to }33\text{ V}$ $I_O = 200\text{ mA}$ | | | 50 | |
| ΔV_O | Load Regulation | $I_O = 5\text{ to }500\text{ mA}$ $T_J = 25^\circ\text{C}$ | | | 360 | mV |
| | | $I_O = 5\text{ to }200\text{ mA}$ $T_J = 25^\circ\text{C}$ | | | 180 | |
| I_d | Quiescent Current | | | | 6 | mA |
| ΔI_d | Quiescent Current Change | $I_O = 5\text{ to }350\text{ mA}$ | | | 0.5 | mA |
| | | $I_O = 200\text{ mA}$ $V_I = 21\text{ to }33\text{ V}$ | | | 0.8 | |
| $\Delta V_O/\Delta T$ | Output Voltage Drift | $I_O = 5\text{ mA}$ $T_J = 0\text{ to }125^\circ\text{C}$ | | -1.1 | | mV/ $^\circ\text{C}$ |
| SVR | Supply Voltage Rejection | $V_I = 22\text{ to }32\text{ V}$ $f = 120\text{ Hz}$ $I_O = 300\text{ mA}$ | 53 | | | dB |
| eN | Output Noise Voltage | $B = 10\text{ Hz to }100\text{ KHz}$ | | 100 | | μV |
| V_d | Dropout Voltage | | | 2 | | V |
| I_{sc} | Short Circuit Current | $V_I = 35\text{ V}$ | | 240 | | mA |

ELECTRICAL CHARACTERISTICS OF L78M20C (refer to the test circuits, $T_J = 25^\circ\text{C}$, $V_I = 29\text{V}$, $I_O = 350\text{ mA}$, $C_I = 0.33\ \mu\text{F}$, $C_O = 0.1\ \mu\text{F}$ unless otherwise specified).

| Symbol | Parameter | Test Conditions | Min. | Typ. | Max. | Unit |
|-----------------------|--------------------------|---|------|------|------|----------------------|
| V_O | Output Voltage | | 19.2 | 20 | 20.8 | V |
| V_O | Output Voltage | $I_O = 5\text{ to }350\text{ mA}$ $V_I = 23\text{ to }35\text{ V}$ | 19 | 20 | 21 | V |
| ΔV_O | Line Regulation | $V_I = 23\text{ to }35\text{ V}$ $I_O = 200\text{ mA}$ | | | 100 | mV |
| | | $V_I = 24\text{ to }35\text{ V}$ $I_O = 200\text{ mA}$ | | | 50 | |
| ΔV_O | Load Regulation | $I_O = 5\text{ to }500\text{ mA}$ $T_J = 25^\circ\text{C}$ | | | 400 | mV |
| | | $I_O = 5\text{ to }200\text{ mA}$ $T_J = 25^\circ\text{C}$ | | | 200 | |
| I_d | Quiescent Current | | | | 6 | mA |
| ΔI_d | Quiescent Current Change | $I_O = 5\text{ to }350\text{ mA}$ | | | 0.5 | mA |
| | | $I_O = 200\text{ mA}$ $V_I = 23\text{ to }35\text{ V}$ | | | 0.8 | |
| $\Delta V_O/\Delta T$ | Output Voltage Drift | $I_O = 5\text{ mA}$ $T_J = 0\text{ to }125^\circ\text{C}$ | | -1.1 | | mV/ $^\circ\text{C}$ |
| SVR | Supply Voltage Rejection | $V_I = 24\text{ to }34\text{ V}$ $f = 120\text{Hz}$ $I_O = 300\text{mA}$ | 53 | | | dB |
| eN | Output Noise Voltage | $B = 10\text{Hz to }100\text{KHz}$ | | 110 | | μV |
| V_d | Dropout Voltage | | | 2 | | V |
| I_{sc} | Short Circuit Current | $V_I = 35\text{ V}$ | | 240 | | mA |

ELECTRICAL CHARACTERISTICS OF L78M24C (refer to the test circuits, $T_J = 25^\circ\text{C}$, $V_I = 33\text{V}$, $I_O = 350\text{ mA}$, $C_I = 0.33\ \mu\text{F}$, $C_O = 0.1\ \mu\text{F}$ unless otherwise specified),

| Symbol | Parameter | Test Conditions | Min. | Typ. | Max. | Unit |
|-----------------------|--------------------------|---|------|------|------|----------------------|
| V_O | Output Voltage | | 23 | 24 | 25 | V |
| V_O | Output Voltage | $I_O = 5\text{ to }350\text{ mA}$ $V_I = 27\text{ to }38\text{ V}$ | 22.8 | 24 | 25.2 | V |
| ΔV_O | Line Regulation | $V_I = 27\text{ to }38\text{ V}$ $I_O = 200\text{ mA}$ | | | 100 | mV |
| | | $V_I = 28\text{ to }38\text{ V}$ $I_O = 200\text{ mA}$ | | | 50 | |
| ΔV_O | Load Regulation | $I_O = 5\text{ to }500\text{ mA}$ $T_J = 25^\circ\text{C}$ | | | 480 | mV |
| | | $I_O = 5\text{ to }200\text{ mA}$ $T_J = 25^\circ\text{C}$ | | | 240 | |
| I_d | Quiescent Current | | | | 6 | mA |
| ΔI_d | Quiescent Current Change | $I_O = 5\text{ to }350\text{ mA}$ | | | 0.5 | mA |
| | | $I_O = 200\text{ mA}$ $V_I = 27\text{ to }38\text{ V}$ | | | 0.8 | |
| $\Delta V_O/\Delta T$ | Output Voltage Drift | $I_O = 5\text{ mA}$ $T_J = 0\text{ to }125^\circ\text{C}$ | | -1.2 | | mV/ $^\circ\text{C}$ |
| SVR | Supply Voltage Rejection | $V_I = 28\text{ to }38\text{ V}$ $f = 120\text{Hz}$ $I_O = 300\text{mA}$ | 50 | | | dB |
| eN | Output Noise Voltage | $B = 10\text{Hz to }100\text{KHz}$ | | 170 | | μV |
| V_d | Dropout Voltage | | | 2 | | V |
| I_{sc} | Short Circuit Current | $V_I = 35\text{ V}$ | | 240 | | mA |

L78M00 SERIES

Figure 4 : Dropout Voltage vs Junction Temperature

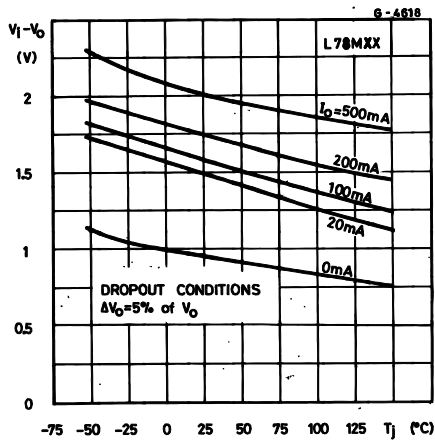

Figure 7 : Output Voltage vs Junction Temperature

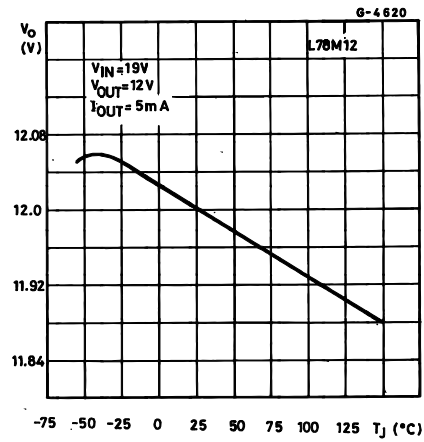

Figure 5 : Dropout Characteristics

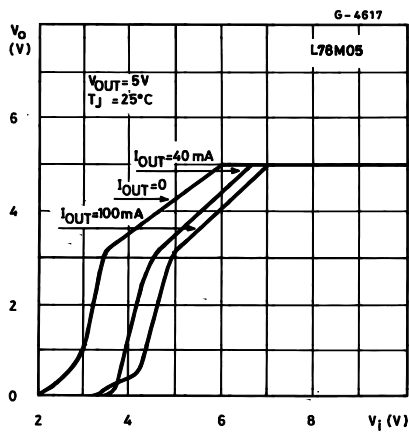

Figure 8 : Supply Voltage Rejection vs Frequency

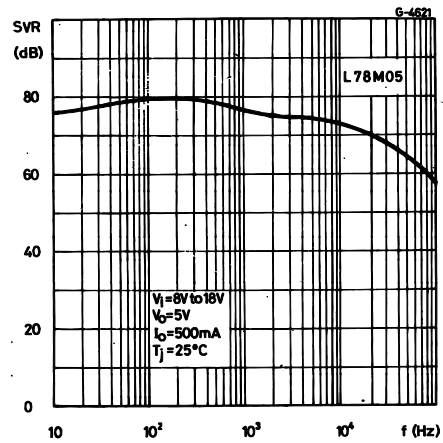

Figure 6 : Peak Output Current vs Input-Output Differential Voltage

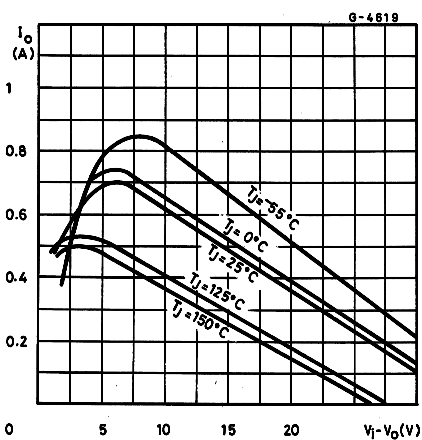

Figure 9 : Quiescent Current vs Junction Temperature

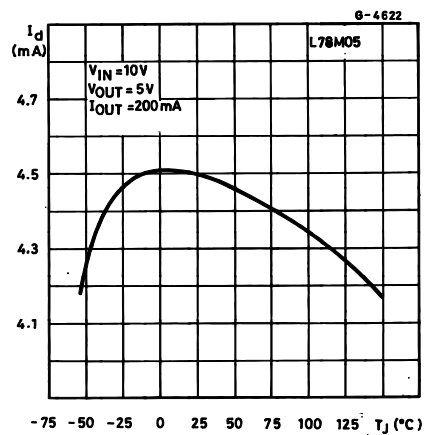

Figure 10 : Load Transient Response

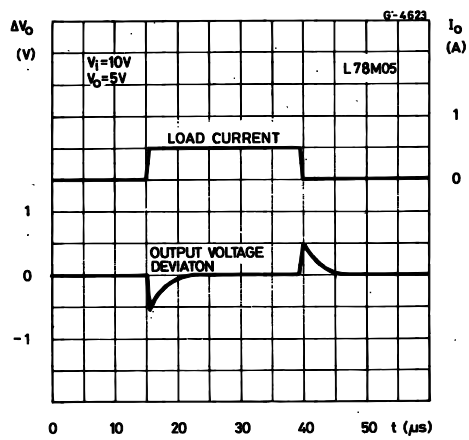

Figure 12 : Quiescent Current vs Input Voltage

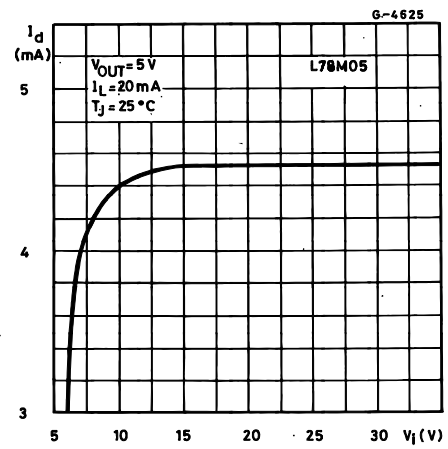
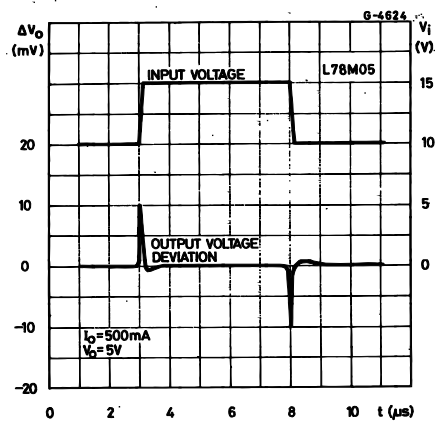
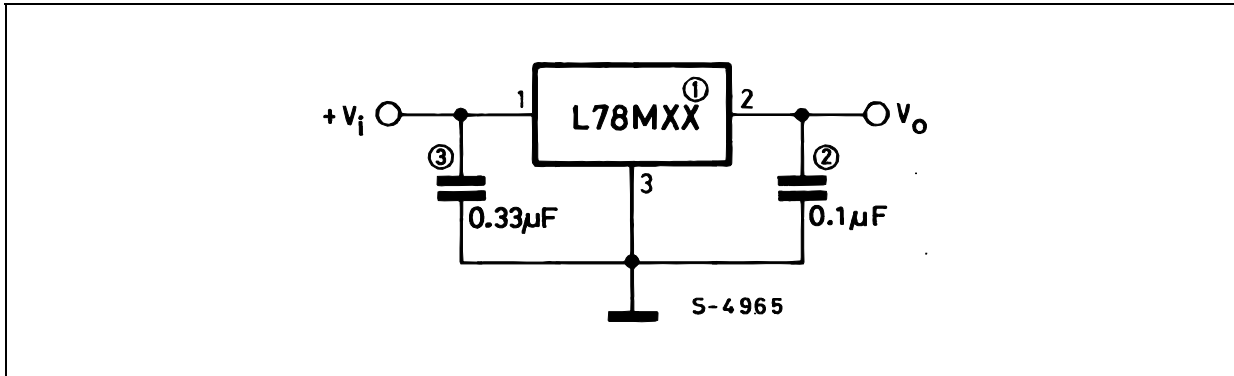

Figure 11 : Line Transient Response



L78M00 SERIES

Figure 13 : Fixed Output Regulator



NOTE:

1. To specify an output voltage, substitute voltage value for "XX".
2. Although no output capacitor is need for stability, it does improve transient response.
3. Required if regulator is locate an appreciable distance from power supply filter.

Figure 14 :

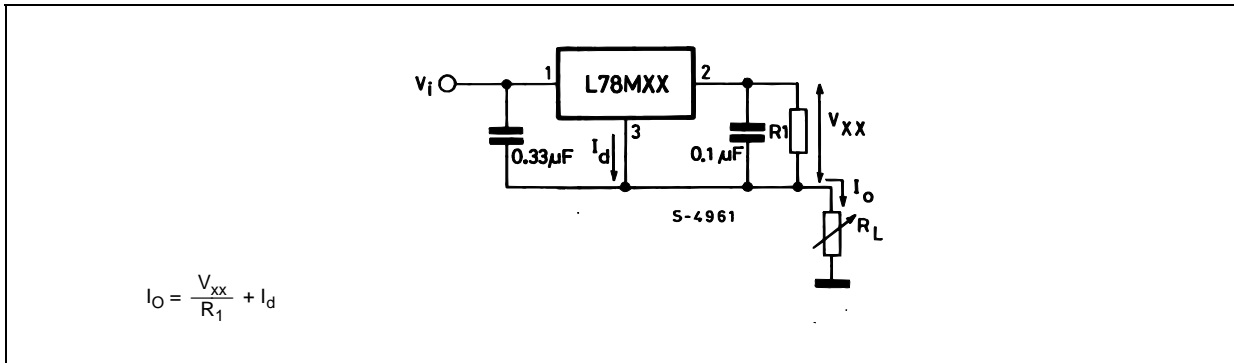

Figure 15 :

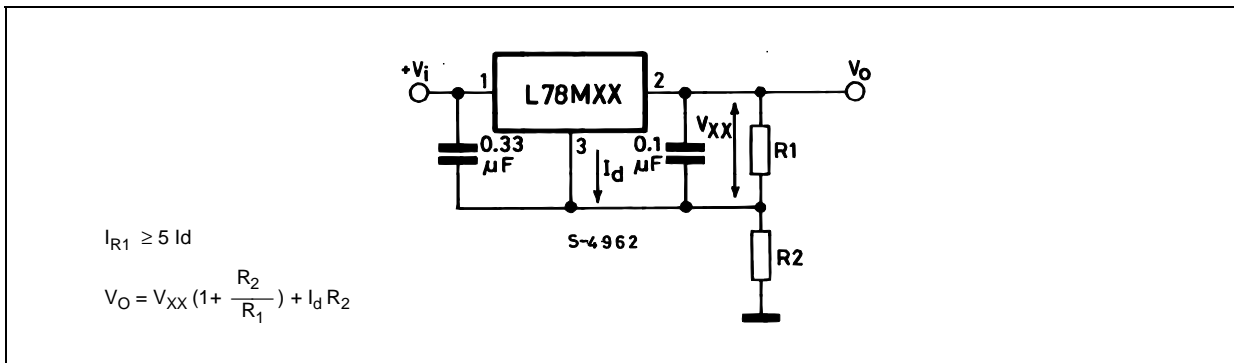

Figure 16 : Adjustable Output Regulator (7 to 30V)

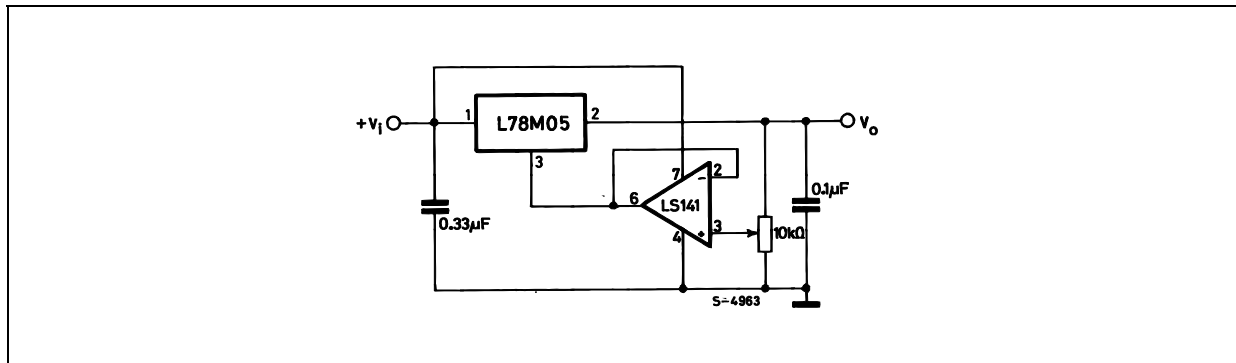

Figure 17 : 0.5 to 10V Regulator

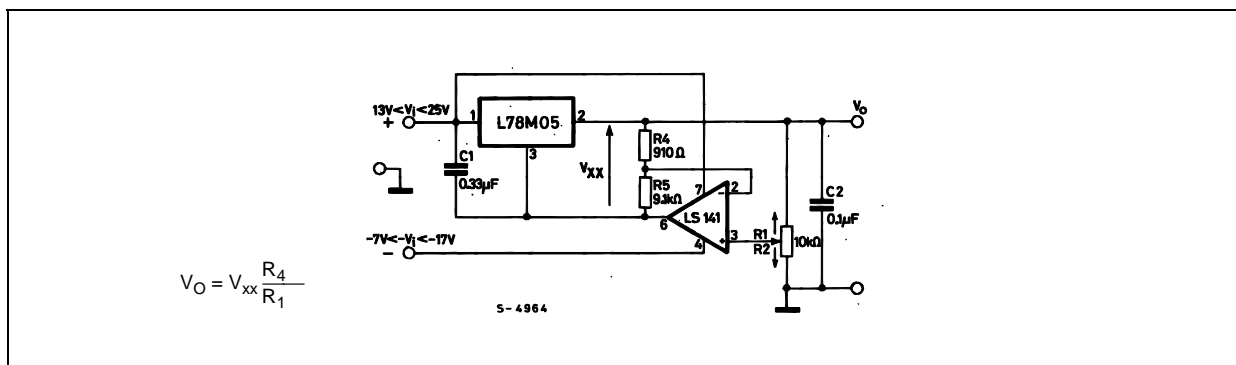

Figure 18 : High Current Voltage Regulator

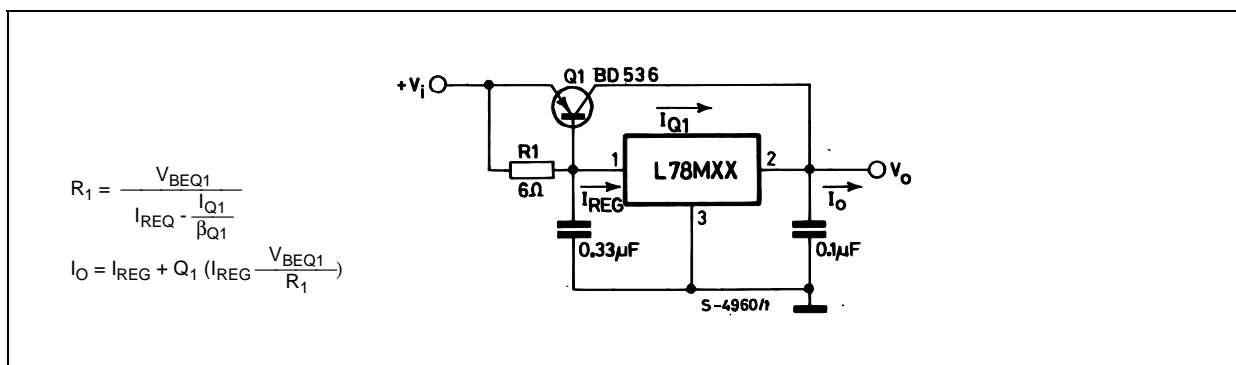
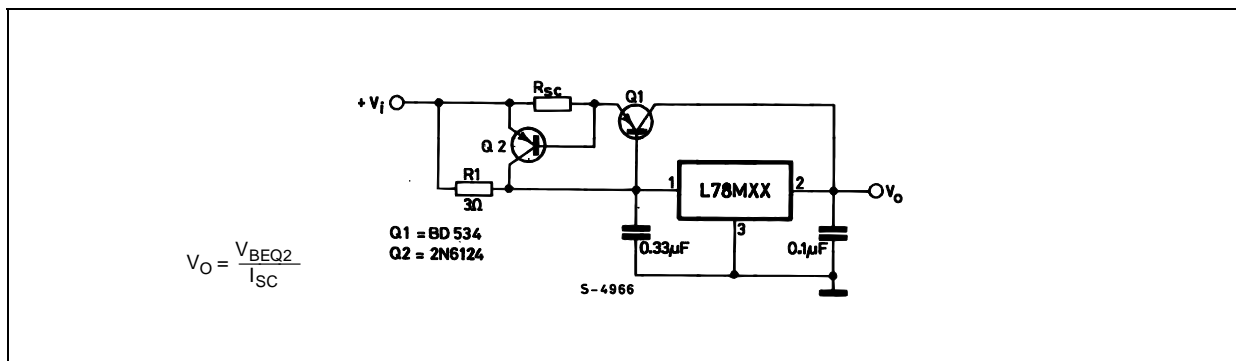

Figure 19 : High Output Current with Short Circuit



L78M00 SERIES

Figure 20 : Tracking Voltage Regulator

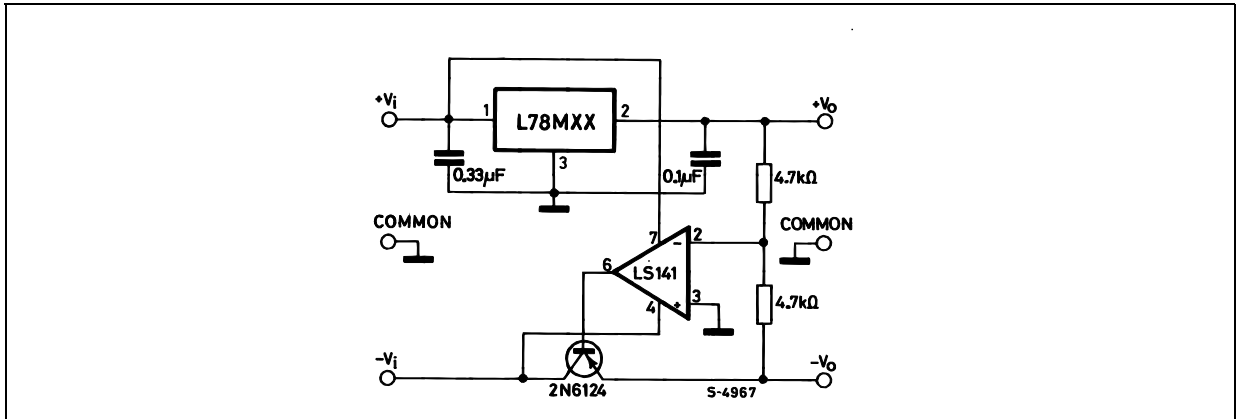

Figure 21 : High Input Voltage Circuit

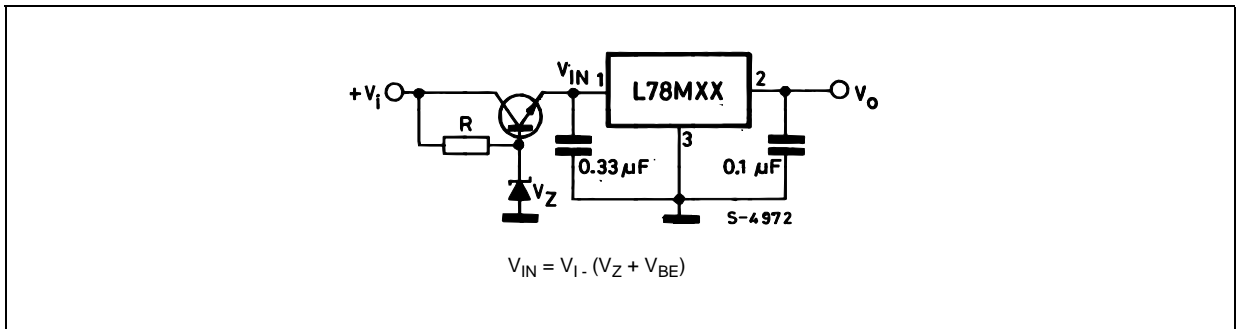

Figure 22 : Reducing Power Dissipation with Dropping Resistor

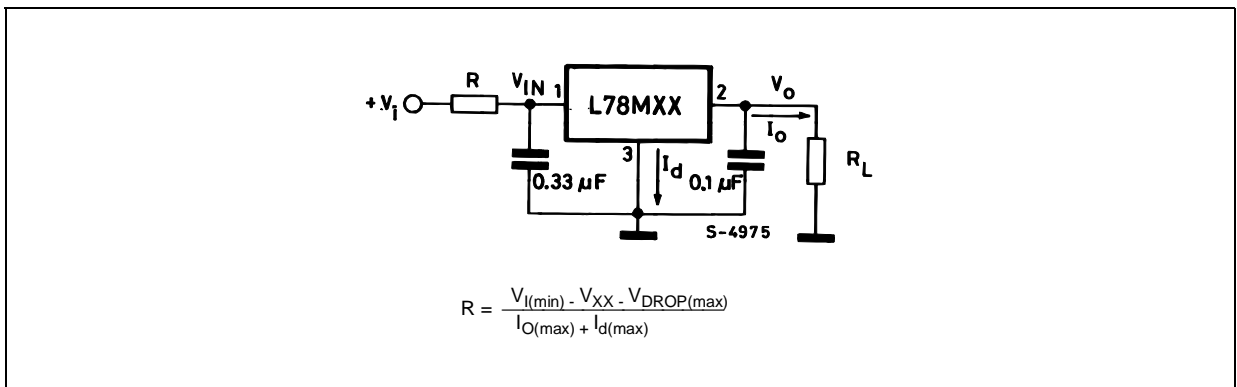
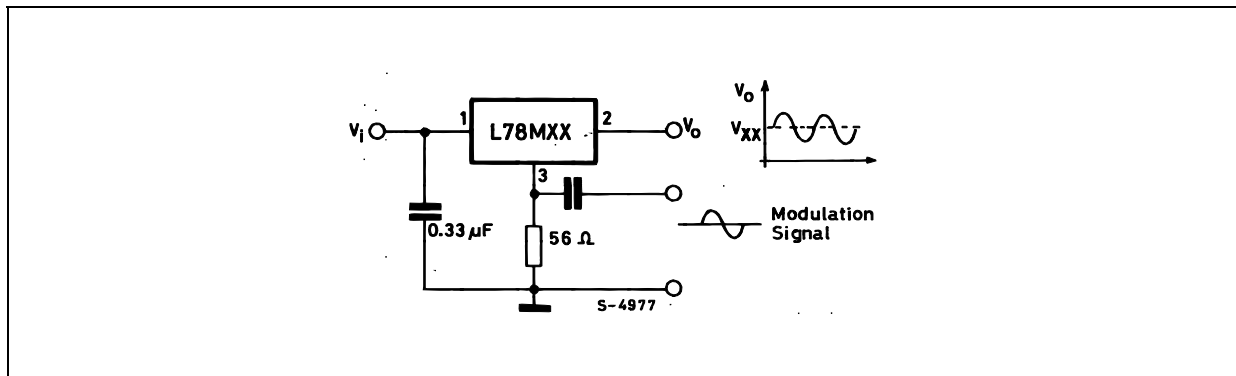
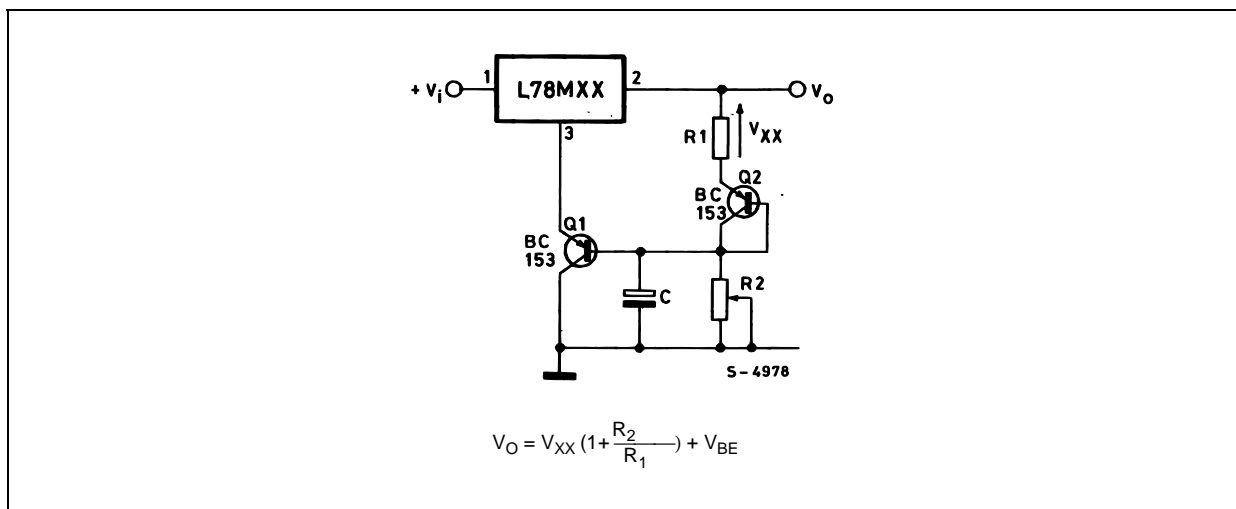

Figure 23 : Power AM Modulator (unity voltage gain, $I_O \leq 0.5$)



NOTE: The circuit performs well up to 100 KHz.

Figure 24 : Adjustable Output Voltage with Temperature Compensation



NOTE: Q_2 is connected as a diode in order to compensate the variation of the Q_1 V_{BE} with the temperature. C allows a slow risetime of the V_O .

L78M00 SERIES

TO-220 MECHANICAL DATA

| DIM. | mm. | | | inch | | |
|------|-------|------|-------|-------|-------|-------|
| | MIN. | TYP | MAX. | MIN. | TYP. | MAX. |
| A | 4.40 | | 4.60 | 0.173 | | 0.181 |
| C | 1.23 | | 1.32 | 0.048 | | 0.051 |
| D | 2.40 | | 2.72 | 0.094 | | 0.107 |
| D1 | | 1.27 | | | 0.050 | |
| E | 0.49 | | 0.70 | 0.019 | | 0.027 |
| F | 0.61 | | 0.88 | 0.024 | | 0.034 |
| F1 | 1.14 | | 1.70 | 0.044 | | 0.067 |
| F2 | 1.14 | | 1.70 | 0.044 | | 0.067 |
| G | 4.95 | | 5.15 | 0.194 | | 0.203 |
| G1 | 2.4 | | 2.7 | 0.094 | | 0.106 |
| H2 | 10.0 | | 10.40 | 0.393 | | 0.409 |
| L2 | | 16.4 | | | 0.645 | |
| L4 | 13.0 | | 14.0 | 0.511 | | 0.551 |
| L5 | 2.65 | | 2.95 | 0.104 | | 0.116 |
| L6 | 15.25 | | 15.75 | 0.600 | | 0.620 |
| L7 | 6.2 | | 6.6 | 0.244 | | 0.260 |
| L9 | 3.5 | | 3.93 | 0.137 | | 0.154 |
| DIA. | 3.75 | | 3.85 | 0.147 | | 0.151 |

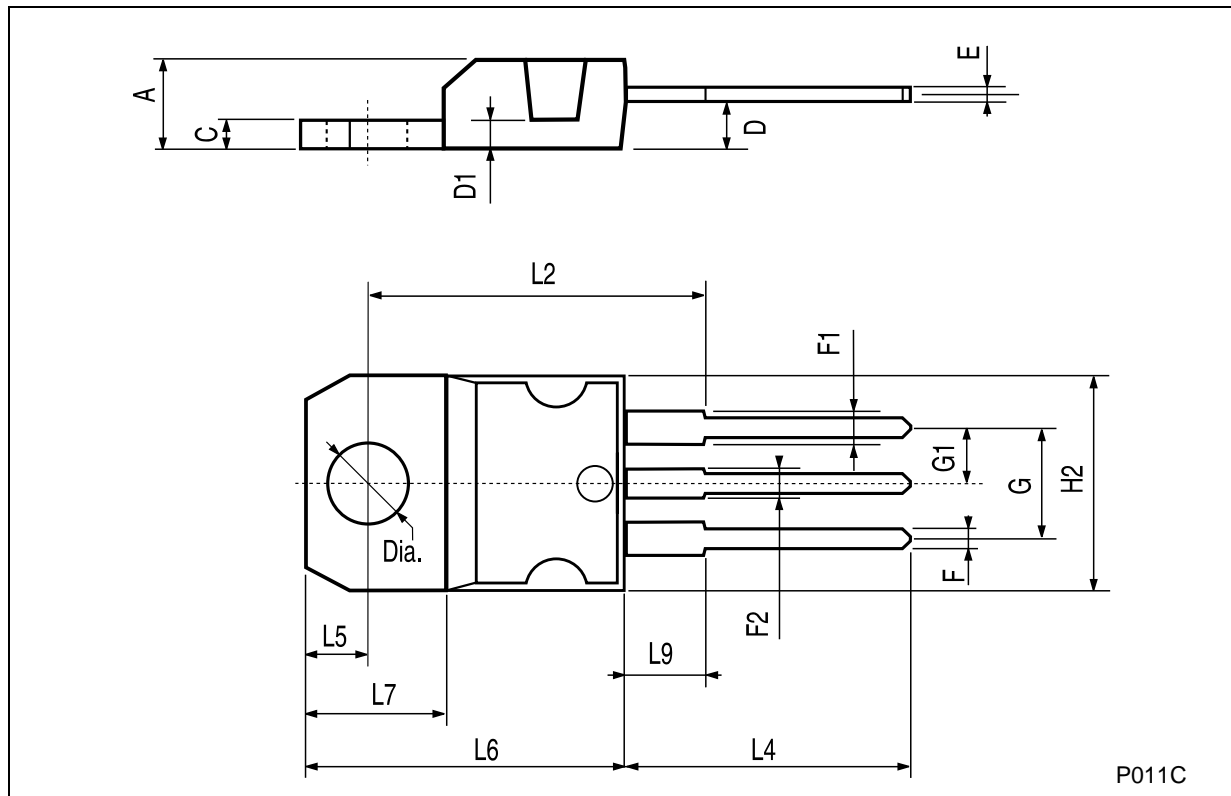

TO-220FP MECHANICAL DATA

| DIM. | mm. | | | inch | | |
|------|------|------|-------|-------|-------|-------|
| | MIN. | TYP. | MAX. | MIN. | TYP. | MAX. |
| A | 4.40 | | 4.60 | 0.173 | | 0.181 |
| B | 2.5 | | 2.7 | 0.098 | | 0.106 |
| D | 2.5 | | 2.75 | 0.098 | | 0.108 |
| E | 0.45 | | 0.70 | 0.017 | | 0.027 |
| F | 0.75 | | 1 | 0.030 | | 0.039 |
| F1 | 1.15 | | 1.50 | 0.045 | | 0.059 |
| F2 | 1.15 | | 1.50 | 0.045 | | 0.059 |
| G | 4.95 | | 5.2 | 0.194 | | 0.204 |
| G1 | 2.4 | | 2.7 | 0.094 | | 0.106 |
| H | 10.0 | | 10.40 | 0.393 | | 0.409 |
| L2 | | 16 | | | 0.630 | |
| L3 | 28.6 | | 30.6 | 1.126 | | 1.204 |
| L4 | 9.8 | | 10.6 | 0.385 | | 0.417 |
| L6 | 15.9 | | 16.4 | 0.626 | | 0.645 |
| L7 | 9 | | 9.3 | 0.354 | | 0.366 |
| DIA. | 3 | | 3.2 | 0.118 | | 0.126 |

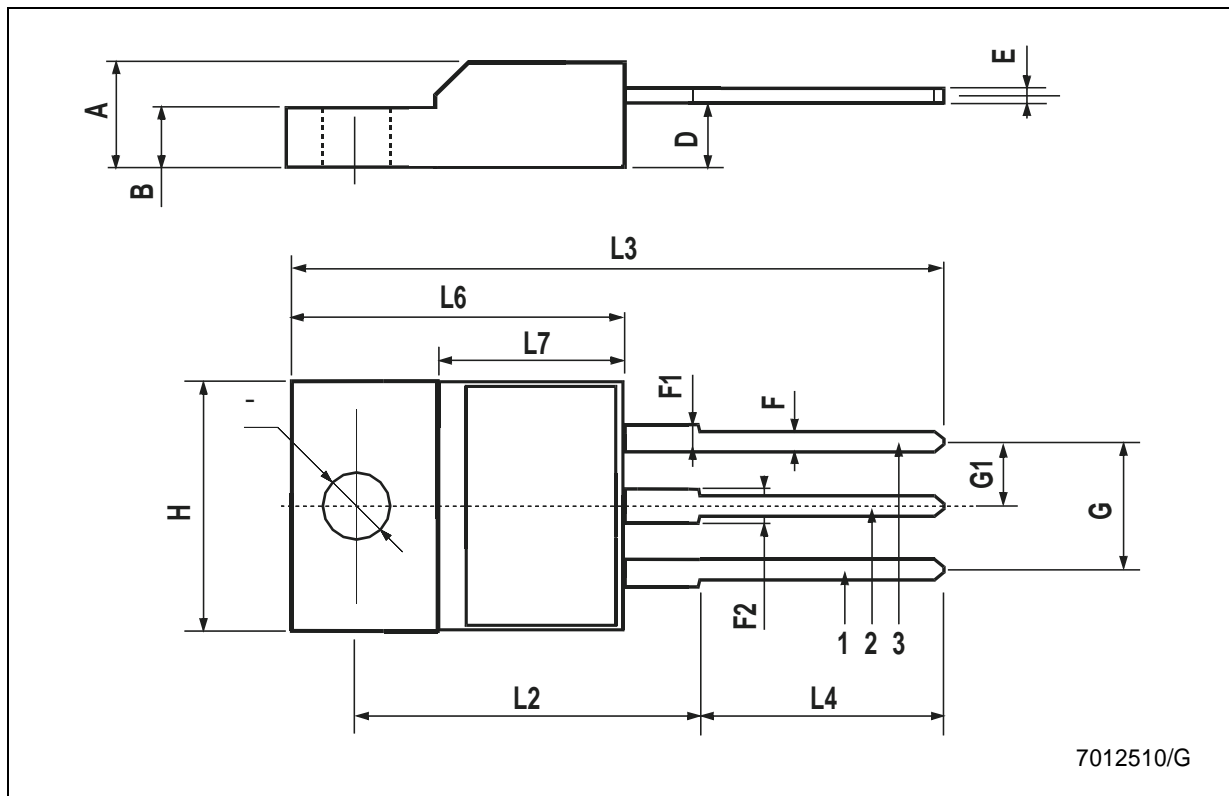

L78M00 SERIES

DPAK MECHANICAL DATA

| DIM. | mm. | | | inch | | |
|------|------|------|------|-------|-------|-------|
| | MIN. | TYP | MAX. | MIN. | TYP. | MAX. |
| A | 2.2 | | 2.4 | 0.086 | | 0.094 |
| A1 | 0.9 | | 1.1 | 0.035 | | 0.043 |
| A2 | 0.03 | | 0.23 | 0.001 | | 0.009 |
| B | 0.64 | | 0.9 | 0.025 | | 0.035 |
| B2 | 5.2 | | 5.4 | 0.204 | | 0.212 |
| C | 0.45 | | 0.6 | 0.017 | | 0.023 |
| C2 | 0.48 | | 0.6 | 0.019 | | 0.023 |
| D | 6 | | 6.2 | 0.236 | | 0.244 |
| D1 | | 5.1 | | | 0.200 | |
| E | 6.4 | | 6.6 | 0.252 | | 0.260 |
| E1 | | 4.7 | | | 0.185 | |
| e | | 2.28 | | | 0.090 | |
| e1 | 4.4 | | 4.6 | 0.173 | | 0.181 |
| H | 9.35 | | 10.1 | 0.368 | | 0.397 |
| L | | 1 | | | 0.039 | |
| (L1) | | 2.8 | | | 0.110 | |
| L2 | | 0.8 | | | 0.031 | |
| L4 | 0.6 | | 1 | 0.023 | | 0.039 |

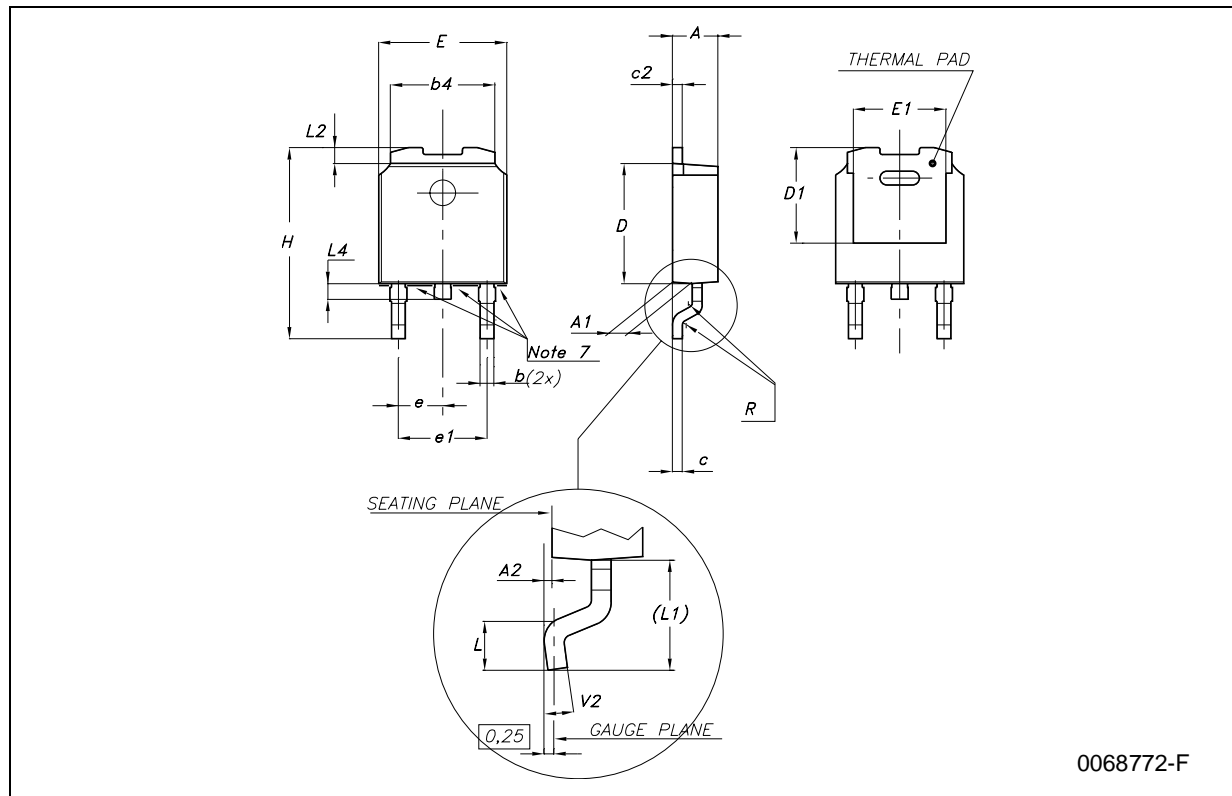

IPAK MECHANICAL DATA

| DIM. | mm. | | | inch | | |
|------|------|-----|------|-------|-------|-------|
| | MIN. | TYP | MAX. | MIN. | TYP. | MAX. |
| A | 2.2 | | 2.4 | 0.086 | | 0.094 |
| A1 | 0.9 | | 1.1 | 0.035 | | 0.043 |
| B | 0.64 | | 0.9 | 0.025 | | 0.035 |
| B2 | 5.2 | | 5.4 | 0.204 | | 0.212 |
| B3 | | | 0.95 | | | 0.037 |
| B5 | | 0.3 | | | 0.012 | |
| B6 | | | 0.95 | | | 0.037 |
| C | 0.45 | | 0.6 | 0.017 | | 0.023 |
| C2 | 0.48 | | 0.6 | 0.019 | | 0.023 |
| D | 6 | | 6.2 | 0.236 | | 0.244 |
| E | 6.4 | | 6.6 | 0.252 | | 0.260 |
| G | 4.4 | | 4.6 | 0.173 | | 0.181 |
| H | 15.9 | | 16.3 | 0.626 | | 0.641 |
| L | 9 | | 9.4 | 0.354 | | 0.370 |
| L1 | 0.8 | | 1.2 | 0.031 | | 0.047 |
| L2 | | 0.8 | 1 | | 0.031 | 0.039 |

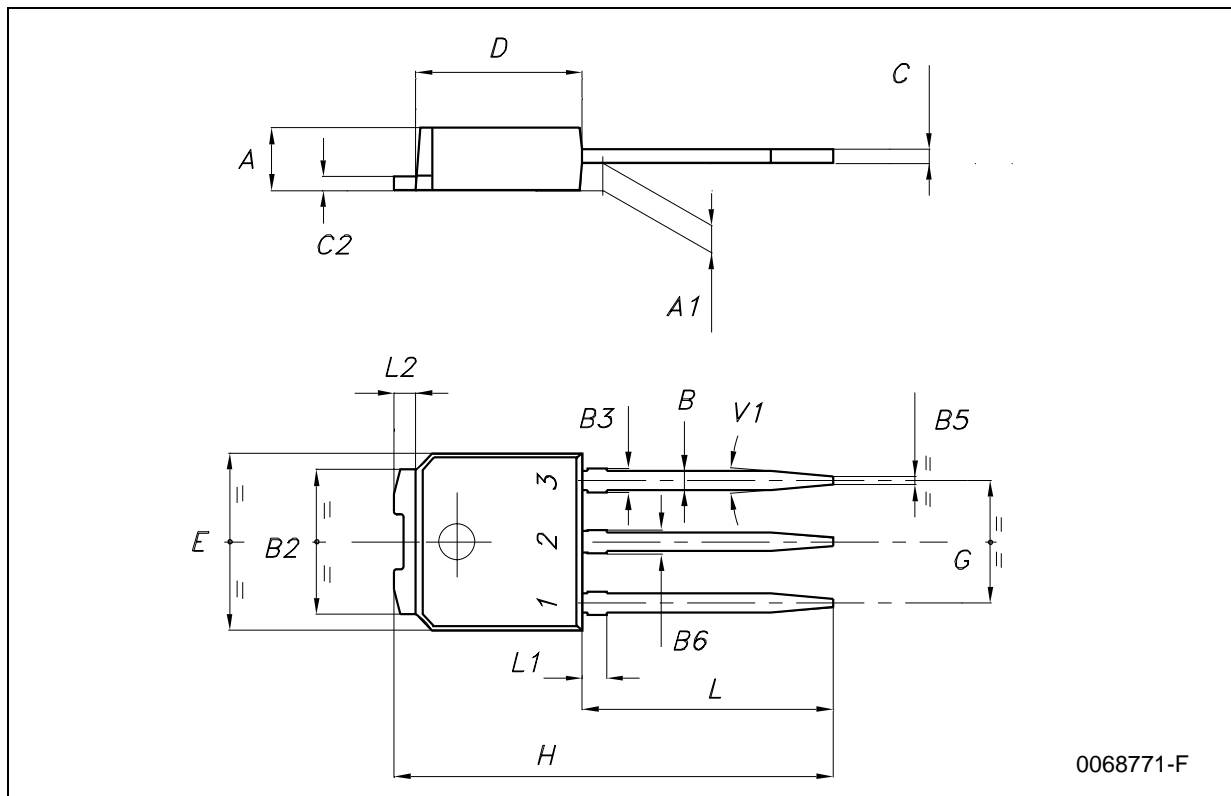

Tape & Reel DPAK-PPAK MECHANICAL DATA

| DIM. | mm. | | | inch | | |
|------|-------|-------|-------|-------|-------|--------|
| | MIN. | TYP | MAX. | MIN. | TYP. | MAX. |
| A | | | 330 | | | 12.992 |
| C | 12.8 | 13.0 | 13.2 | 0.504 | 0.512 | 0.519 |
| D | 20.2 | | | 0.795 | | |
| N | 60 | | | 2.362 | | |
| T | | | 22.4 | | | 0.882 |
| Ao | 6.80 | 6.90 | 7.00 | 0.268 | 0.272 | 0.276 |
| Bo | 10.40 | 10.50 | 10.60 | 0.409 | 0.413 | 0.417 |
| Ko | 2.55 | 2.65 | 2.75 | 0.100 | 0.104 | 0.105 |
| Po | 3.9 | 4.0 | 4.1 | 0.153 | 0.157 | 0.161 |
| P | 7.9 | 8.0 | 8.1 | 0.311 | 0.315 | 0.319 |

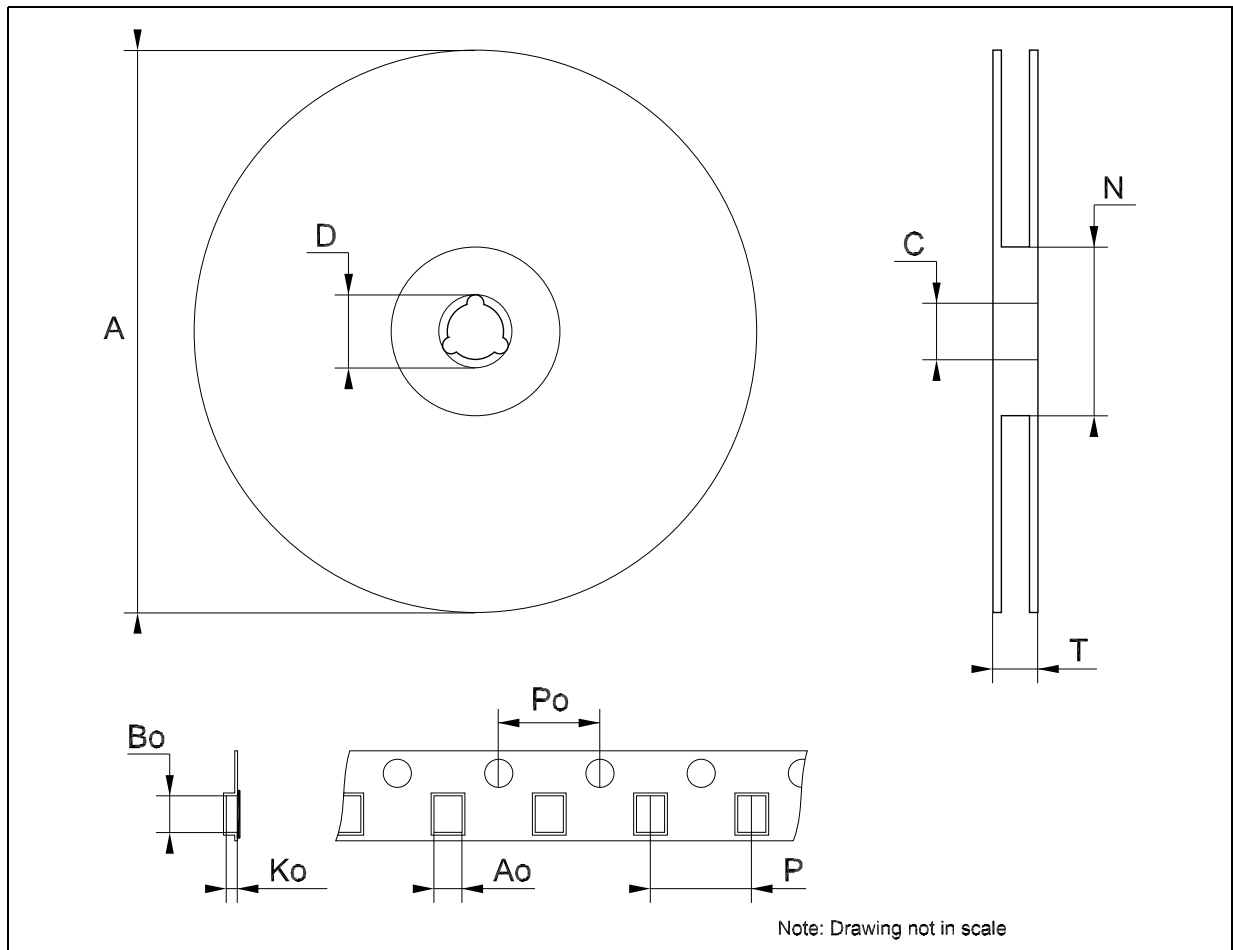

Information furnished is believed to be accurate and reliable. However, STMicroelectronics assumes no responsibility for the consequences of use of such information nor for any infringement of patents or other rights of third parties which may result from its use. No license is granted by implication or otherwise under any patent or patent rights of STMicroelectronics. Specifications mentioned in this publication are subject to change without notice. This publication supersedes and replaces all information previously supplied. STMicroelectronics products are not authorized for use as critical components in life support devices or systems without express written approval of STMicroelectronics.

The ST logo is a registered trademark of STMicroelectronics
All other names are the property of their respective owners

© 2004 STMicroelectronics - All Rights Reserved
STMicroelectronics GROUP OF COMPANIES

Australia - Belgium - Brazil - Canada - China - Czech Republic - Finland - France - Germany - Hong Kong - India - Israel - Italy - Japan -
Malaysia - Malta - Morocco - Singapore - Spain - Sweden - Switzerland - United Kingdom - United States.

<http://www.st.com>