

THIS DRAWING IS UNPUBLISHED. RELEASED FOR PUBLICATION, 19  
 © COPYRIGHT 19 BY AMP INCORPORATED. ALL INTERNATIONAL RIGHTS RESERVED.

LOC	DIST	P	F	REVISIONS			DATE	APPD
AF	50			ZONE	LTR	DESCRIPTION		
					Y	REV PER 0G3A-0425-01	27JUL01	JR/PD

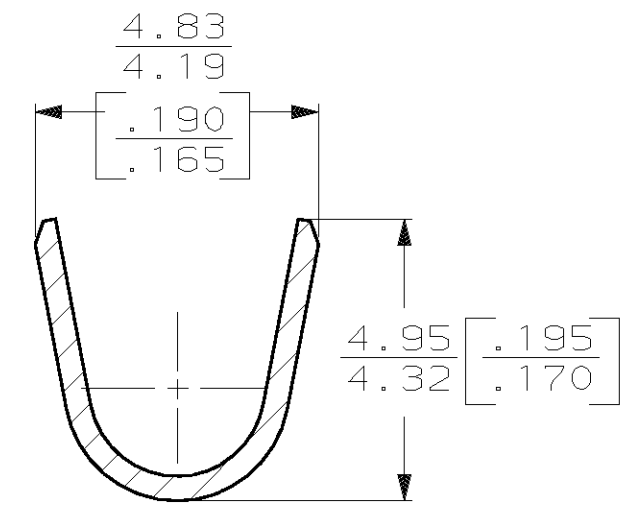
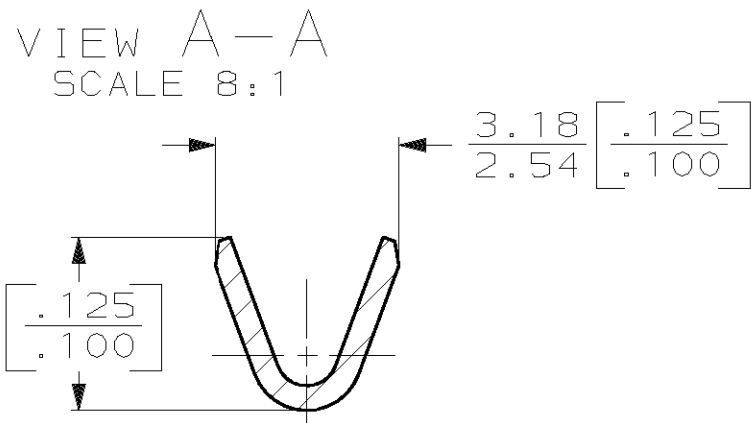
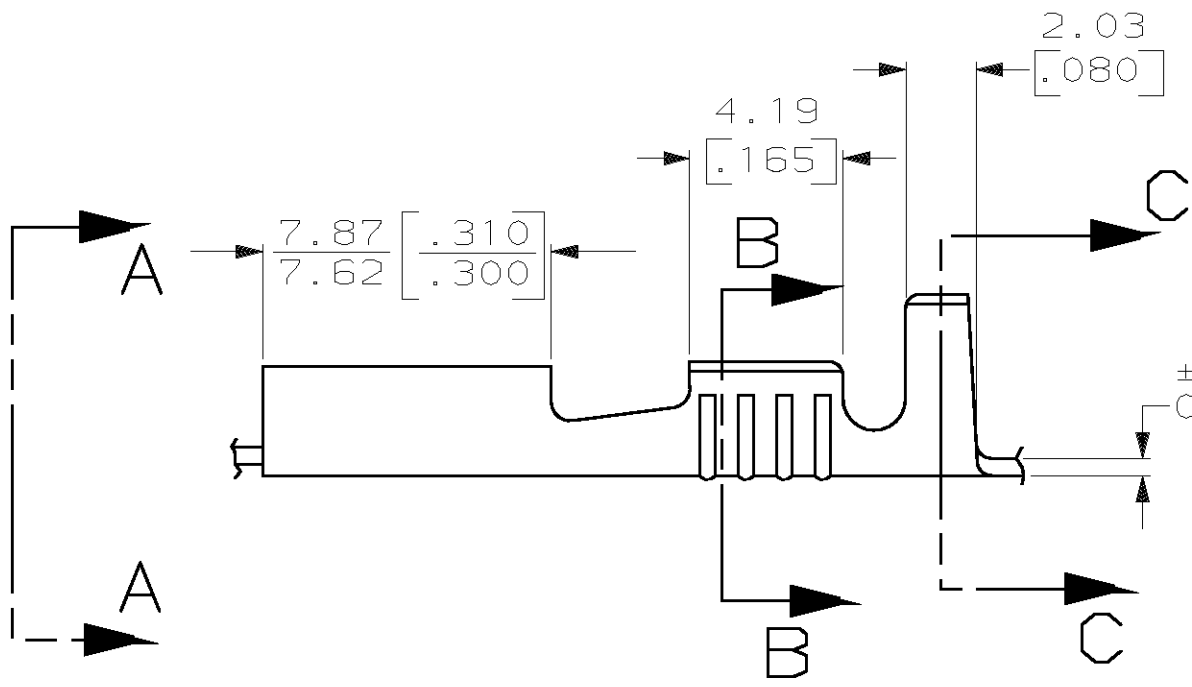
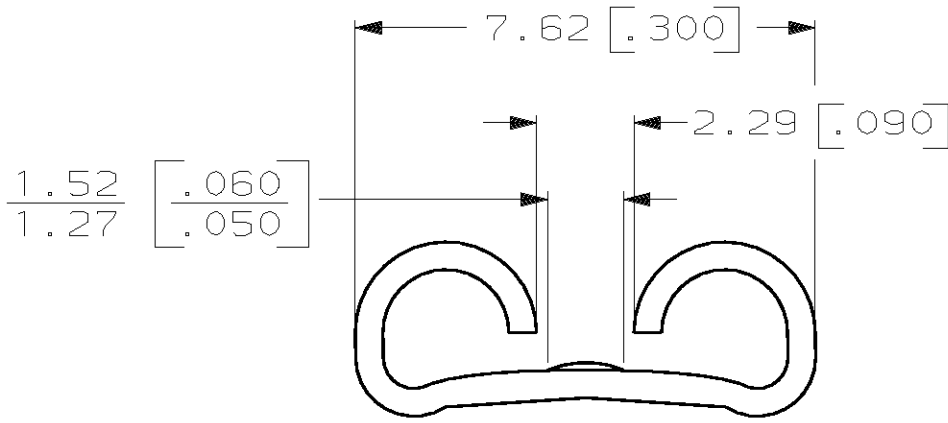
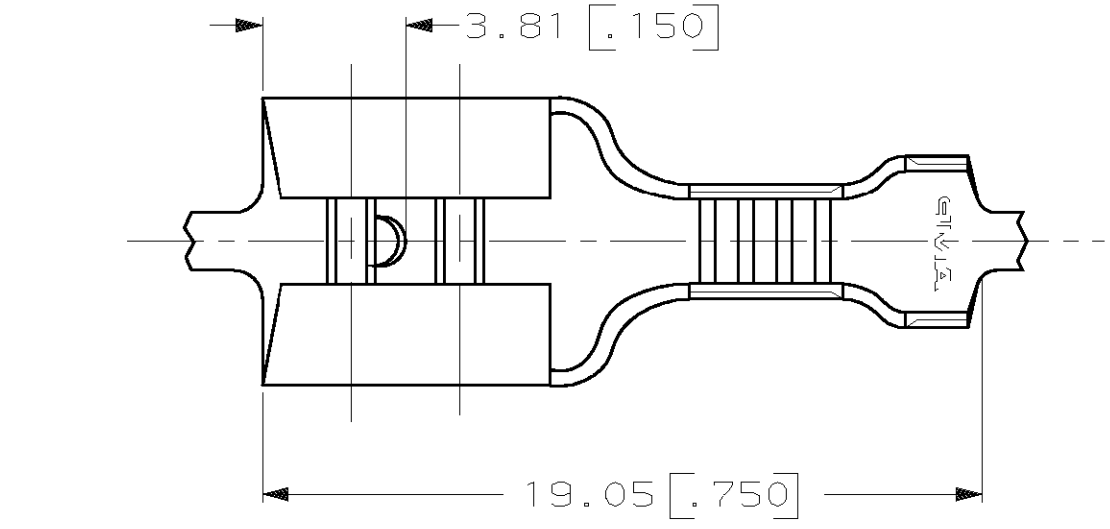

- 1 DIMENSIONS IN BRACKETS ARE IN INCHES
- 2 CONTINUOUS STRIP ON REELS
- ③ FOREIGN PRODUCTION ONLY
- ④ FOREIGN PRODUCTION ONLY, INTERLEAVING PAPER REQUIRED
- ⑤ REELED UPSIDE DOWN WITH INTERLEAVING PAPER.
- ⑥ PRELIMINARY - NOT FOR PRODUCTION
- ⑦ FOR AMP ITALY ONLY, NOT STRESS RELIEVED.

2.29-3.30 [.090-.130]	0.3-0.8mm <sup>2</sup> [22-18]	±0.025 ±.001 0.81 [.032]	⑦ 1-41772-1 ⑥ ⑤ 41772-4 ④ 41772-3 ③ 41772-1 41772
INSUL RANGE	WIRE SIZE	MATING TAB THK	PART NO
DO NOT SCALE PRINT. UNLESS SPECIFIED DIMENSIONS ARE IN MM [INCHES] TOLERANCES ON: 2 PLC DEC ± - 3 PLC DEC ± 0.25 [.010] ANGLES ± -	DR 4/26/89 JR RUTH CHK 4/26/89 MS FEHER APPD 4/26/89 C MEYERS APPD 4/26/89 R KUZO	AMP INCORPORATED Harrisburg, Pa. 17105	
MATERIAL H04 BRASS	PRODUCT SPEC -	NAME RECEPTACLE, FASTON,™ .250 SERIES	
FINISH TIN 0.002032 [.000080] MIN	APPLICATION SPEC 114-2036 WEIGHT -	SIZE <b>B</b>	FSCM NO 00779
		SCALE 5:1	DRAWING NO 41772
			SHEET 1 OF 1