

Single Turn Trimmer

Model 82



Features:

- 1/4" diameter
- Single turn
- Cermet

Electrical

Standard Resistance Range, Ohms	10 to 1Meg
Standard Resistance Tolerance	±10% (<100 Ohms = ±20%)
Input Voltage, Maximum	200 Vdc or rms not to exceed power rating
Slider Current, Maximum	100mA or within rated power, whichever is less
Power Rating, Watts	0.5 at 70°C derating to 0 at 125°C
End Resistance, Maximum	2 Ohms
Actual Electrical Travel, Nominal	220°
Dielectric Strength	600 Vrms
Insulation Resistance, Minimum	1,000 Megohms
Resolution	Essentially infinite
Contact Resistance Variation, Maximum	1% or 1 Ohm, whichever is greater

Environmental

Seal	85°C Fluorinert® (No Leaks)
Temperature Coefficient, Maximum	±100ppm/°C
Operating Temperature Range	-55°C to +125°C
Thermal Shock	5 cycles, -55°C to +125°C (1% ΔRT, 1% ΔVR)
Moisture Resistance	Ten 24 hour cycles (1% ΔRT, IR 100 Megohms Min.)
Shock, 6ms Sawtooth	100G's (1% ΔRT, 1% ΔVR)
Vibration	20G's, 10 to 2,000 Hz (1% ΔRT, 1% ΔVR)
High Temperature Exposure	250 hours at 125°C (2% ΔRT, 2% ΔVR)
Rotational Life	200 cycles (3% ΔRT)
Load Life at 0.5 Watts	1,000 hours at 70°C (2% ΔRT)
Resistance to Solder Heat	260°C for 10 sec. (1% ΔRT)

Mechanical

Mechanical Stops	Solid
Torque, Starting Maximum	3 oz.-in. (0.021 N-m)
Weight, Nominal	.02 oz. (0.60 grams)

General Note
TT Electronics reserves the right to make changes in product specification without notice or liability. All information is subject to TT Electronics' own data and is considered accurate at time of going to print.

© TT electronics plc

TT Electronics | BI Technologies
413 Rood RD, Suite 7
Calexico, CA 92231
Ph: + 1 (714) 447-2345
www.ttelectronics.com/bi-technologies

Issue B 04/2019 Page 1

Packaging Information

Standard: Boxes

Capacity = 50 Units (82PA, 82PF)
 = 100 Units (All other styles)

Option: Tubes

All units oriented with #1 pin to same side.

	Pin Style	PA	P,M,W
Magazine	Width	= 0.28"	0.34"
	Height	= 0.94"	0.65"
	Length	= 15.6"	27.5"
	Capacity	= 50 Units	100 Units

Option: Tape & Reel, Ammo Pack (Available for 82W Only)

All units oriented with #1 pin to the right of the direction of feed.

	Seat Plane to Centerline of Sprocket Hole	= .71" (18.03 mm)
Tape	Width	= 18 mm
	Sprocket	= Single Hole .50" spacing
	Capacity	= 1,000 Units
Reel	Diameter	= 14" (356 mm)
Ammo	Tape Fold	= 12" (305 mm)
Box		= 1.5" x 13" x 10"

Ordering Information

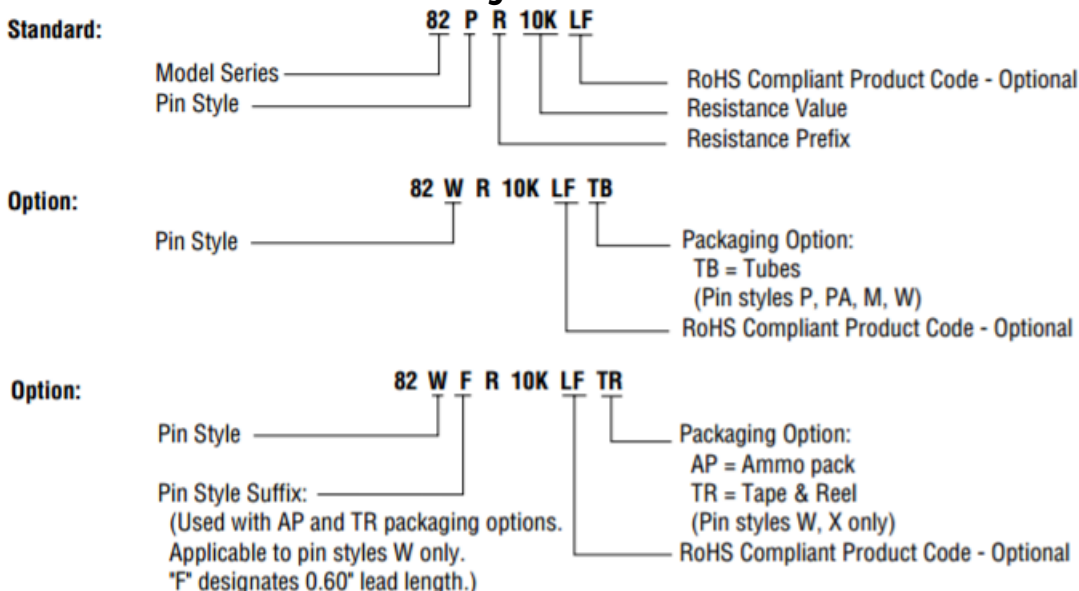

General Note
 TT Electronics reserves the right to make changes in product specification without notice or liability. All information is subject to TT Electronics' own data and is considered accurate at time of going to print.

© TT electronics plc

TT Electronics | BI Technologies
 413 Rood RD, Suite 7
 Calexico, CA 92231
 Ph: +1 (714) 447-2345
 www.ttelectronics.com/bi-technologies

Outline Drawings—Top Adjustment

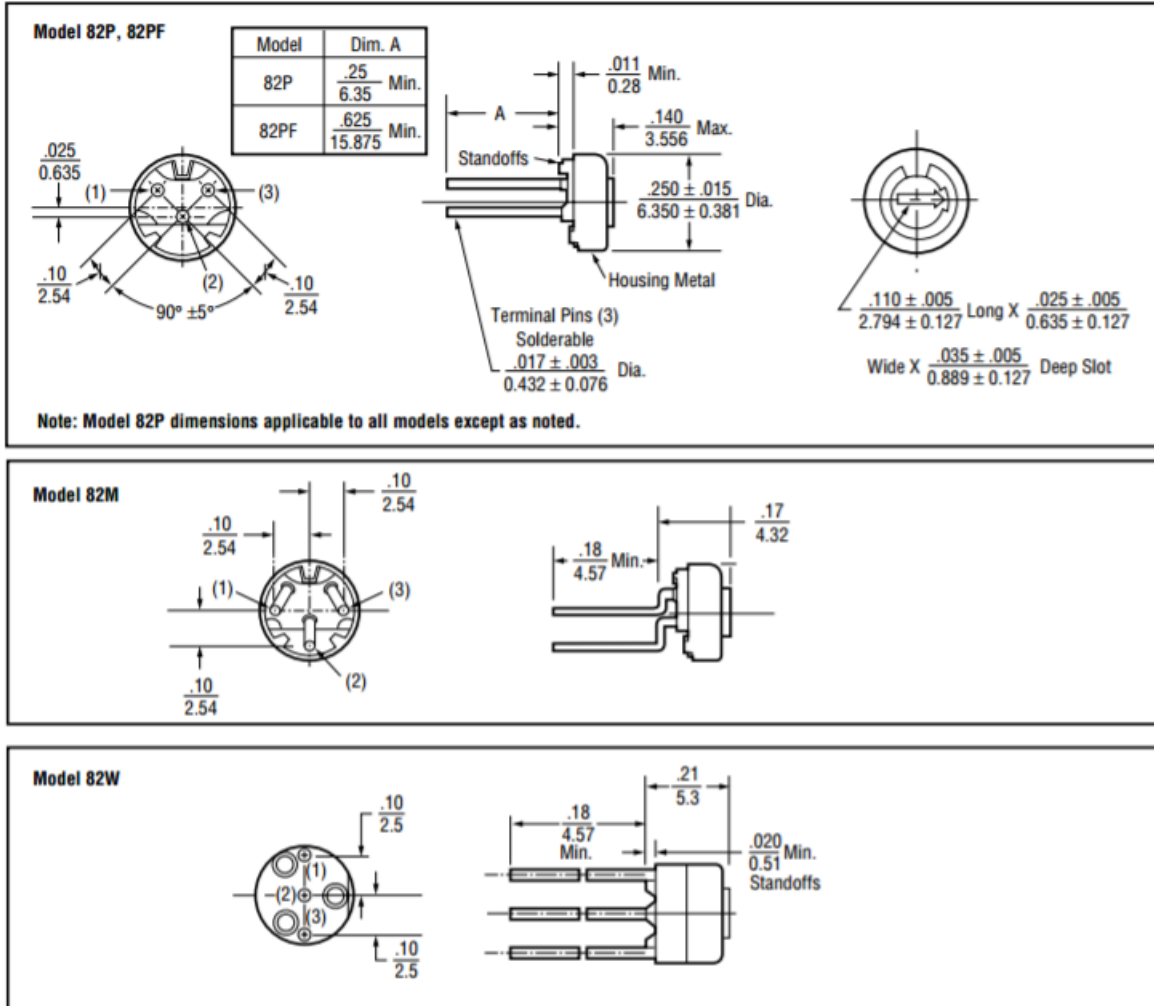

Outline Drawings—Side Adjustment



Standard Resistance Values, Ohms

10	100	1K	10K	50K	250K
20	200	2K	20K	100K	500K
50	500	5K	25K	200K	1Meg

Circuit Diagram

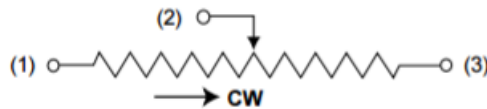

NOTES

Metric equivalents, based on 1 inch = 25.4mm are rounded to the same number of significant figures as in the original English units and are provided for general information only.

Tolerances unless otherwise specified:
 Linear = $\pm .01$ inches (.25mm)
 Angular = ± 2 degrees

