

| DATE | REV | ECN | APP'D. BY |
|---------|-----|-------|-----------|
| 3-22-17 | A9 | 10943 | TRM |
| 8-25-17 | A10 | 11072 | TRM |
| | | | |
| | | | |

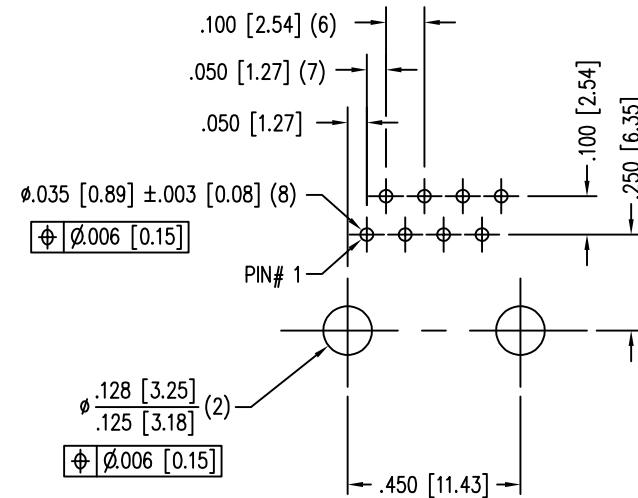
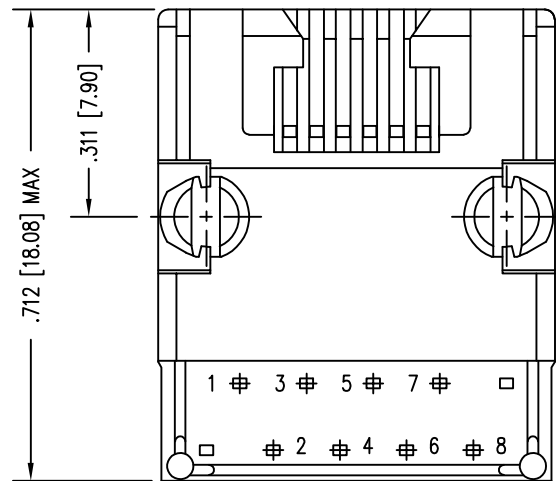
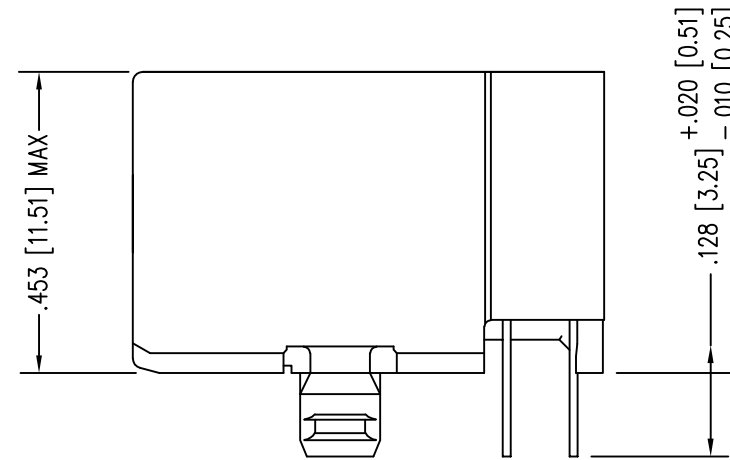
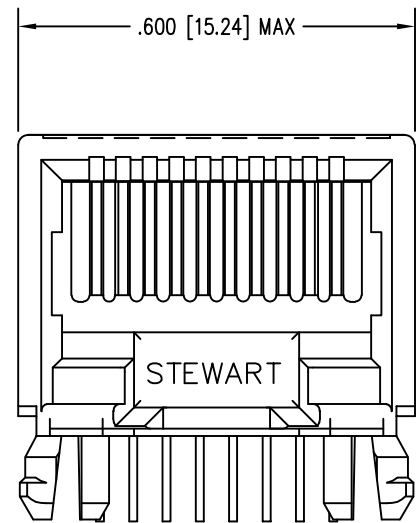

P.C.B. RECOMMENDED HOLE LAYOUT
SEEN FROM COMPONENT SIDE
ALL CENTERLINE DIMENSIONS ARE BASIC.

NOTES:

- CONNECTOR MATERIALS:
HOUSING: THERMOPLASTIC UL94 V-0
CONTACTS: COPPER ALLOY
CONTACT PLATING: SELECTIVE GOLD IN CONTACT AREA
SEE CHART FOR PART NUMBER
- FOR PRODUCT SPECIFICATIONS SEE PRO22-01.
- DIMENSIONS AND TOLERANCES COMPLY WITH TIA-1096 STANDARD.

| | |
|-----------------------------------|--------------|
| 30 MICRO-INCHES [0.76um] | SS-700810-NF |
| CONTACT PLATING IN MATING AREA | PART NUMBER |

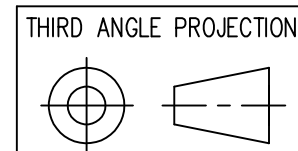

1118 Susquehanna Trail South
Glen Rock, PA 17327-9199
(717) 235-7512
<http://www.stewartconnector.com>

DO NOT SCALE DRAWING
DRAWING IS SUBJECT TO
CHANGE WITHOUT NOTICE

DIMENSIONS: INCHES [METRIC]

UNLESS OTHERWISE SPECIFIED
TOLERANCES ARE ±.005 [0.13]
ANGLES ARE ± 1°

SHEET NO. 1 OF 1

| | |
|---|-------------|
| TITLE: EIGHT POSITION, EIGHT CONTACT JACK, UNSHIELDED | |
| DRN BY: RGC | DATE 6-5-02 |
| APPD BY: JRC | DATE 6-5-02 |
| DWG NO. CT700009 | REV. A10 |



Mouser Electronics

Authorized Distributor

Click to View Pricing, Inventory, Delivery & Lifecycle Information:

Bel:

[SS-700810-NF](#)