

## Hexa half-bridge driver with SPI control for automotive applications

### Features

- 6 half bridges
- $R_{ON} = \text{typ.} 0.9 \Omega$  (HS),  $0.64 \Omega$  (LS) at  $T_j = 25 \text{ }^\circ\text{C}$
- Current limit of each output at minimum 0.8 A
- Internal PWM generation
- PWM mode option for all half bridges for hold current
- Two current monitor outputs
- SPI interface for data communication
- Temperature warning
- All outputs overtemperature protected
- All outputs short circuit protected
- $V_{CC}$  supply voltage 3.0 to 5.3 V
- Very low current consumption in standby mode typ.  $5 \mu\text{A}$
- $V_S$  operating range compliant: 6 – 18 V

### Applications

- DC motor driver Intended to drive HVAC flaps

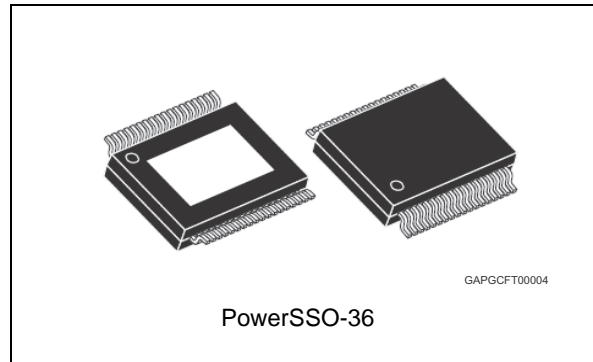

### Description

The L99MD02 IC is a 6 x half bridge driver for automotive applications. The device is intended to drive DC-motors. It is possible to drive 3 DC-motors simultaneously or up to 5 DC-motors sequentially.

The integrated 24 bit standard serial peripheral interface (SPI) controls all outputs and provides diagnostic information: normal operation, open-load in on-state, overcurrent, temperature warning and overtemperature.

**Table 1. Device summary**

Package	Order code	
	Tube	Tape and reel
PowerSSO-36	L99MD02XP	L99MD02XPTR

# Contents

- 1      Block diagram ..... 6**
  
- 2      Overview ..... 7**
  - 2.1    Power supply:  $V_{CC}$  ..... 7
  - 2.2    Power supply:  $V_{SA}, V_{SB}$  ..... 7
  - 2.3    Standby mode ..... 7
  - 2.4    PWM mode ..... 8
  - 2.5    Current monitor ..... 8
  - 2.6    Inductive loads ..... 8
  - 2.7    Diagnostic functions ..... 8
  - 2.8    Temperature warning and thermal shutdown ..... 8
  - 2.9     $V_S, V_{SA}, V_{SB}$  monitoring ..... 9
  - 2.10   Open-load detection ..... 9
  - 2.11   Overload detection ..... 9
  - 2.12   Cross-current protection ..... 9
  
- 3      Pin definitions and functions ..... 11**
  
- 4      Electrical specifications ..... 13**
  - 4.1    Absolute maximum ratings ..... 13
  - 4.2    ESD protection ..... 13
  - 4.3    Thermal data ..... 13
  - 4.4    Electrical characteristics ..... 14
  
- 5      SPI electrical characteristics ..... 19**
  - 5.1    SPI timing parameter definition ..... 21
  
- 6      Functional description of the SPI ..... 23**
  - 6.1    Signal description ..... 23
    - 6.1.1    Serial clock (SCK) ..... 23
    - 6.1.2    Serial data input (SDI) ..... 23
    - 6.1.3    Serial data output (SDO) ..... 23
    - 6.1.4    Chip select not (CSN) ..... 23



---

6.2	SPI communication flow .....	24
6.2.1	General description .....	24
6.2.2	Command byte .....	25
6.3	Write operation .....	28
6.4	Read operation .....	28
6.5	Read and clear status operation .....	28
6.6	Read device information .....	29
<b>7</b>	<b>SPI control and status register .....</b>	<b>30</b>
<b>8</b>	<b>Application examples .....</b>	<b>37</b>
<b>9</b>	<b>Package and PCB thermal data .....</b>	<b>39</b>
9.1	PowerSSO-36 thermal data .....	39
<b>10</b>	<b>Package information .....</b>	<b>41</b>
10.1	ECOPACK <sup>®</sup> package .....	41
10.2	PowerSSO-36 <sup>™</sup> mechanical data .....	41
10.3	Packing information .....	43
<b>11</b>	<b>Revision history .....</b>	<b>44</b>

## List of tables

Table 1.	Device summary . . . . .	1
Table 2.	$V_S$ , $V_{SA}$ , $V_{SB}$ monitoring . . . . .	9
Table 3.	Pin description . . . . .	11
Table 4.	Absolute maximum ratings . . . . .	13
Table 5.	ESD protection . . . . .	13
Table 6.	Operating junction temperature . . . . .	13
Table 7.	Temperature warning and thermal shutdown . . . . .	14
Table 8.	Supply. . . . .	14
Table 9.	Over and undervoltage detection . . . . .	14
Table 10.	Switches . . . . .	15
Table 11.	Current monitor output . . . . .	17
Table 12.	Current monitor dynamic characteristics. . . . .	18
Table 13.	Oscillator. . . . .	18
Table 14.	DC characteristics. . . . .	19
Table 15.	AC characteristics. . . . .	19
Table 16.	Dynamic characteristics . . . . .	19
Table 17.	Command byte (8 bit) . . . . .	25
Table 18.	Data byte . . . . .	25
Table 19.	Operating code definition . . . . .	25
Table 20.	Global status byte . . . . .	26
Table 21.	Reset . . . . .	27
Table 22.	RAM memory map . . . . .	30
Table 23.	ROM memory map (access with OC0 and OC1 set to '1') . . . . .	30
Table 24.	Control status register. . . . .	31
Table 25.	Control register 1 (read/write); address 01h . . . . .	32
Table 26.	Control register 3 (read/write); address 03h . . . . .	32
Table 27.	Control register 4 (read/write); address 04h . . . . .	33
Table 28.	Ratio for CURR2. . . . .	33
Table 29.	Ratio for CURR1 . . . . .	34
Table 30.	Control register 5 (read/write); address 05h . . . . .	34
Table 31.	Control register 6 (read/write); address 06h . . . . .	35
Table 32.	Status register 0 (read only); address 10h . . . . .	35
Table 33.	Status register 1 (read only); address 11h . . . . .	36
Table 34.	Status register 2 (read only); address 12h . . . . .	36
Table 35.	PowerSSO-36 mechanical data . . . . .	42
Table 36.	Document revision history . . . . .	44

## List of figures

Figure 1.	Detailed block diagram . . . . .	6
Figure 2.	Power on reset . . . . .	7
Figure 3.	Pin connection (top view-not in scale) . . . . .	12
Figure 4.	Output turn-on/off delays and slew rates . . . . .	16
Figure 5.	SPI timing . . . . .	21
Figure 6.	Serial output timing . . . . .	22
Figure 7.	Clock polarity and clock phase . . . . .	23
Figure 8.	SPI frame structure . . . . .	24
Figure 9.	Indication of the global error flag on SDO when CSN is low and SCK is stable . . . . .	27
Figure 10.	Driving 3 DC-motors simultaneously . . . . .	37
Figure 11.	Driving 5 DC-motors sequentially . . . . .	38
Figure 12.	PowerSSO-36 PC board . . . . .	39
Figure 13.	PowerSSO-36 thermal impedance junction ambient . . . . .	40
Figure 14.	PowerSSO-36™ package dimensions . . . . .	41
Figure 15.	PowerSSO-36 tube shipment (no suffix) . . . . .	43
Figure 16.	PowerSSO-36 tape and reel shipment (suffix "TR") . . . . .	43

# 1 Block diagram

Figure 1. Detailed block diagram

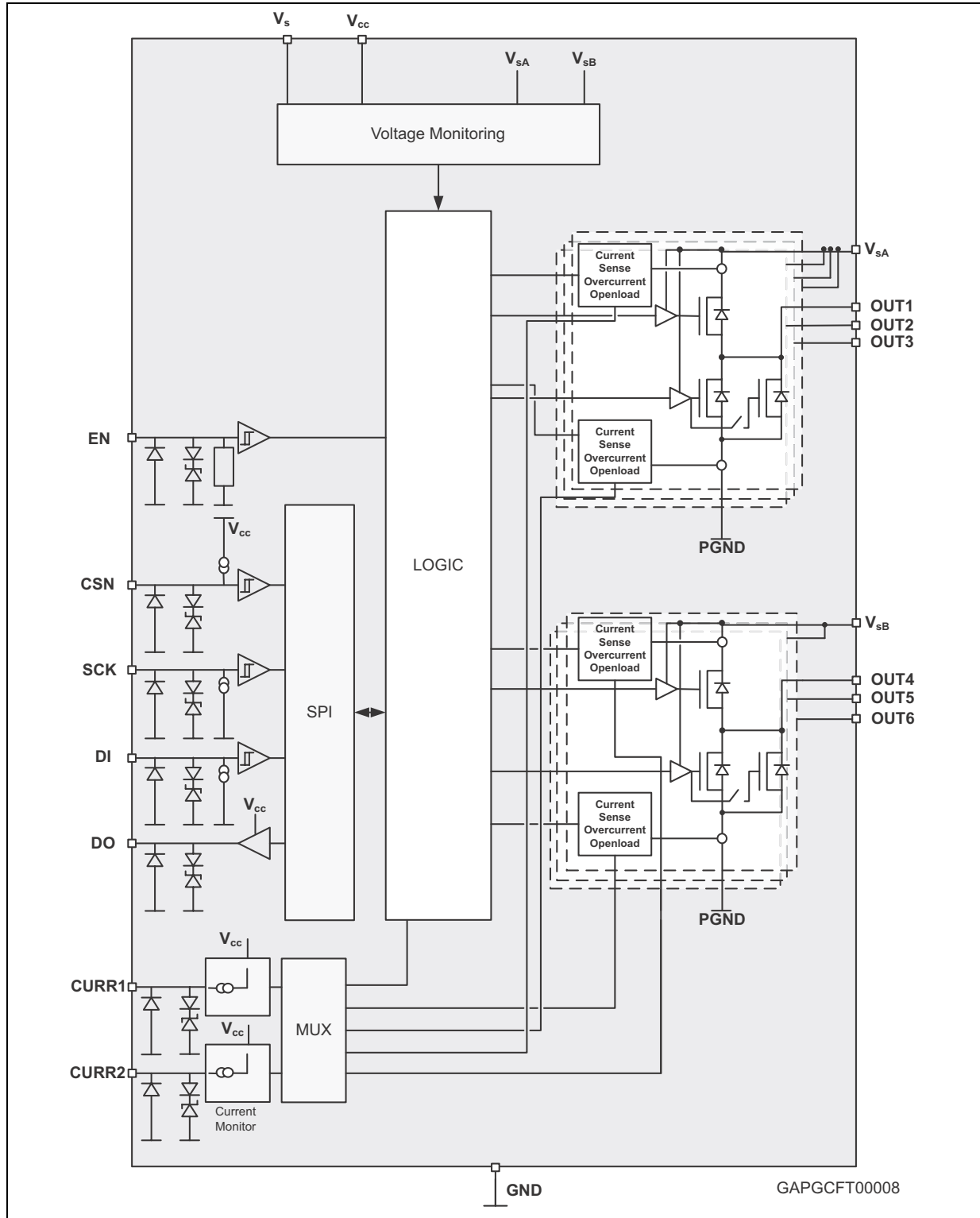

## 2 Overview

### 2.1 Power supply: $V_{CC}$

The supply voltage  $V_{CC}$  (3.3 V / 5 V) supplies the whole device. In case of power-on ( $V_{CC}$  increases from undervoltage to  $V_{POR\ OFF} = 2.75$  V, typical) the circuit is initialized by an internally generated power-on reset (POR). If the voltage  $V_{CC}$  decreases under the minimum threshold ( $V_{POR\ ON} = 2.55$  V, typical), the outputs are switched off in 3-state (high impedance). The status registers are cleared and the control registers are reset to their default.

**Figure 2. Power on reset**

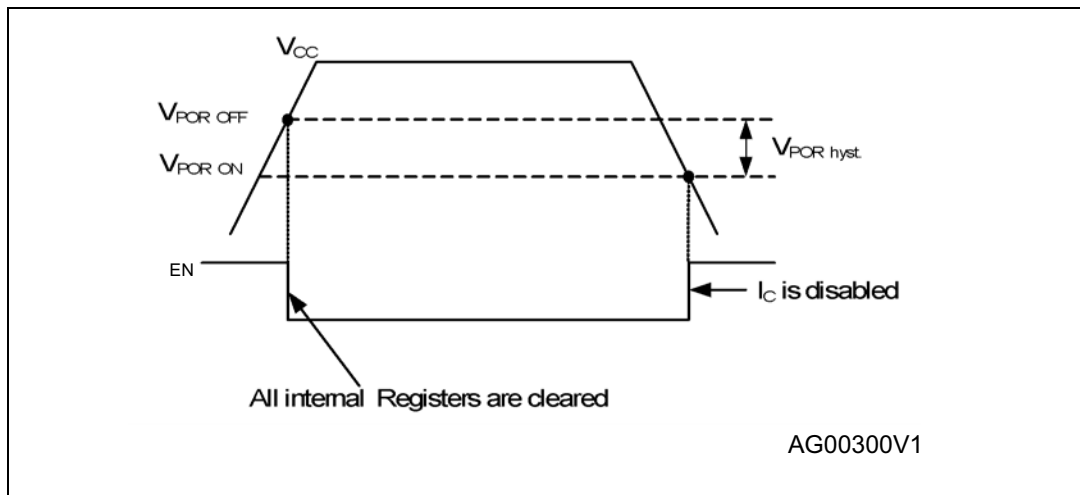

### 2.2 Power supply: $V_{SA}$ , $V_{SB}$

Each  $V_{SA}$  and  $V_{SB}$  supplies the half bridges independently.

$V_{SA} \rightarrow$  Out 1 to Out 3

$V_{SB} \rightarrow$  Out 4 to Out 6

### 2.3 Standby mode

The standby mode of the L99MD02 is activated by EN pin to low. The inputs and outputs are switched off. The status registers are cleared and the control registers are reset to their default values.

In the standby mode the current consumption is typically 5  $\mu$ A.

## 2.4 PWM mode

PWM frequency typ. 100 Hz.

Duty cycle (SPI 2bit): 15%, 30%, 45% and 60%.

Each half-bridge is independently addressable (SPI 8bit).

## 2.5 Current monitor

The current monitor output sources a current image at the current monitor output which has a programmable ratio (1/250, 1/500, 1/750, 1/1000) of the instantaneous current of the selected half bridge (high side or low side). Via SPI it can be programmed which of the outputs will be multiplexed to the current monitor output.

The current monitor output allows a more precise analysis of the actual state of the load rather than the detection of an open-or overload condition. For example this can be used to detect the motor state (starting, free-running, stalled).

## 2.6 Inductive loads

Each half bridge is built by an internally connected high-side and a low-side power DMOS transistor. Due to the built-in reverse diodes of the output transistors, inductive loads can be driven at the outputs

## 2.7 Diagnostic functions

All diagnostic functions (over/open-load, temperature warning and thermal shutdown, over/undervoltage) are internally filtered and the condition has to be valid for at least 32  $\mu$ s (open-load: typ. 2 ms, respectively) before the corresponding status bit in the status registers will be set. The filters are used to improve the noise immunity of the device. Open-load and temperature warning function are intended for information purpose and will not change the state of the output drivers. On contrary, the overload and thermal shutdown condition will disable the corresponding driver (overload) or all drivers (thermal shutdown), respectively. The microcontroller has to clear the overcurrent status bit to reactivate the corresponding driver.

## 2.8 Temperature warning and thermal shutdown

If the junction temperature rises above  $T_{jTW ON}$  a temperature warning flag is set and is detectable via the SPI. If the junction temperature increases above the second threshold  $T_{jSD ON}$ , the thermal shutdown bit will be set and power DMOS transistors of all output stages are switched off to protect the device. Temperature warning flag and thermal shutdown bits are latched. In order to reactivate the output stages, the junction temperature must decrease below  $T_{jSD ON} - T_{jSD HYS}$  and the thermal shutdown bit has to be cleared by the microcontroller.



## 2.9 $V_S$ , $V_{SA}$ , $V_{SB}$ monitoring

- $V_S$  undervoltage: Status bit will be set. Have to be cleared via SPI.  
All outputs will be switched off.
- $V_S$  overvoltage: Status bit will be set. Has to be cleared via SPI.  
All outputs will be switched off (default). Can be deactivated via SPI.
- $V_{SA}$  undervoltage: Status bit will be set. Has to be cleared via SPI.  
Out 1 to Out 6 will be switched off.
- $V_{SB}$  undervoltage: Status bit will be set. Has to be cleared via SPI.  
Out 1 to Out 6 will be switched off.

**Table 2.**  $V_S$ ,  $V_{SA}$ ,  $V_{SB}$  monitoring

	'typ	Out x
$V_S$ undervoltage	5.7 V	Status + off
$V_S$ overvoltage	22.0 V	Status + (off or mask)
$V_{SA}$ undervoltage	5.7 V	Status + off
$V_{SB}$ undervoltage	5.7 V	Status + off

## 2.10 Open-load detection

The open-load detection monitors the load current in each activated output stage. If the load current is below the open-load detection threshold for at least 2 ms ( $t_{dOL}$ ) the corresponding open-load bit is set in the status register.

Due to mechanical/electrical inertia of typical loads a short activation of the outputs (e.g. 3 ms) can be used to test the open-load status without changing the mechanical/ electrical state of the loads.

## 2.11 Overload detection

In case of an overcurrent condition, a flag is set in the corresponding status register. If the overcurrent signal is valid for at least  $t_{ISC} = 32 \mu\text{s}$ , the overcurrent flag is set and the corresponding switch is switched off to reduce the power dissipation and to protect the integrated circuit. The microcontroller has to clear the status bit to reactivate the corresponding driver.

## 2.12 Cross-current protection

The device is cross-current protected by an internal delay time. If one driver (LS or HS) is turned-off the activation of the other driver of the same half bridge will be automatically delayed by the cross-current protection time. After the cross-current protection time is expired the slew-rate limited switch-off phase of the driver will be changed to a fast turn-off phase and the opposite driver is turned-on with slew-rate limitation. Due to this behavior it is

always guaranteed that the previously activated driver is totally turned-off before the opposite driver will start to conduct. If wrong SPI commands try to turn-on both driver (LS and HS) simultaneously, the high side and the low side will be (or stay) deactivated (3-state).

### 3 Pin definitions and functions

**Table 3. Pin description**

Pin	Symbol	Function
1, 18, 19, 36	P <sub>GND</sub>	Power ground: reference potential
9	A <sub>GND</sub>	Analog ground: reference potential
27	D <sub>GND</sub>	Digital ground: reference potential
6, 10, 13, 21, 23, 25, 32, 34	N.C.	Not connected
		Exposed pad: reference potential connected to P <sub>GND</sub>
2, 3, 16, 17, 20, 35	OUT 1 -6	Half bridge-output: the output is built by a high-side and a low-side switch, which are internally connected. The output stage of both switches is a power DMOS transistor. Each driver has an internal parasitic reverse diode (bulk-drain-diode: high-side driver from output to V <sub>Sx</sub> , low-side driver from P <sub>GND</sub> to output).
29	V <sub>CC</sub>	Logic voltage supply 3.3V / 5V for this input a ceramic capacitor as close as possible to GND is recommended
4, 5, 33	V <sub>SA</sub>	Power supply voltage for OUT 1 to 3 (external reverse protection required): for this input a ceramic capacitor as close as possible to GND is recommended. Important: For the capability of driving the full current at the outputs all pins of V <sub>SA</sub> must be externally connected!
14, 15, 22	V <sub>SB</sub>	Power supply voltage for OUT 4 to 6 (external reverse protection required): for this input a ceramic capacitor as close as possible to GND is recommended. Important: For the capability of driving the full current at the outputs all pins of V <sub>SB</sub> must be externally connected!
11	V <sub>S</sub>	V <sub>S</sub>
12	V <sub>S</sub>	V <sub>S</sub> supply and monitoring
7, 8	CURR1 / 2	Current monitor 1 / 2
31	EN	Enable enable the L99MD02
28	DI	SPI data in the input requires CMOS logic levels and receives serial data from the microcontroller. The data is a 24 bit control word and the most significant bit (MSB) is transferred first.
26	DO	SPI data out the diagnosis data is available via the SPI and this 3-state output. The output will remain in 3-state, if the chip is not selected by the input CSN (CSN = high)
24	CSN	SPI CSN chip select not (active low) this input is low active and requires CMOS logic levels. The serial data transfer between the L99MD02 and micro controller is enabled by pulling the input CSN to low level.
30	SCK	SPI serial clock input this input controls the internal shift register of the SPI and requires CMOS logic levels.

Figure 3. Pin connection (top view-not in scale)

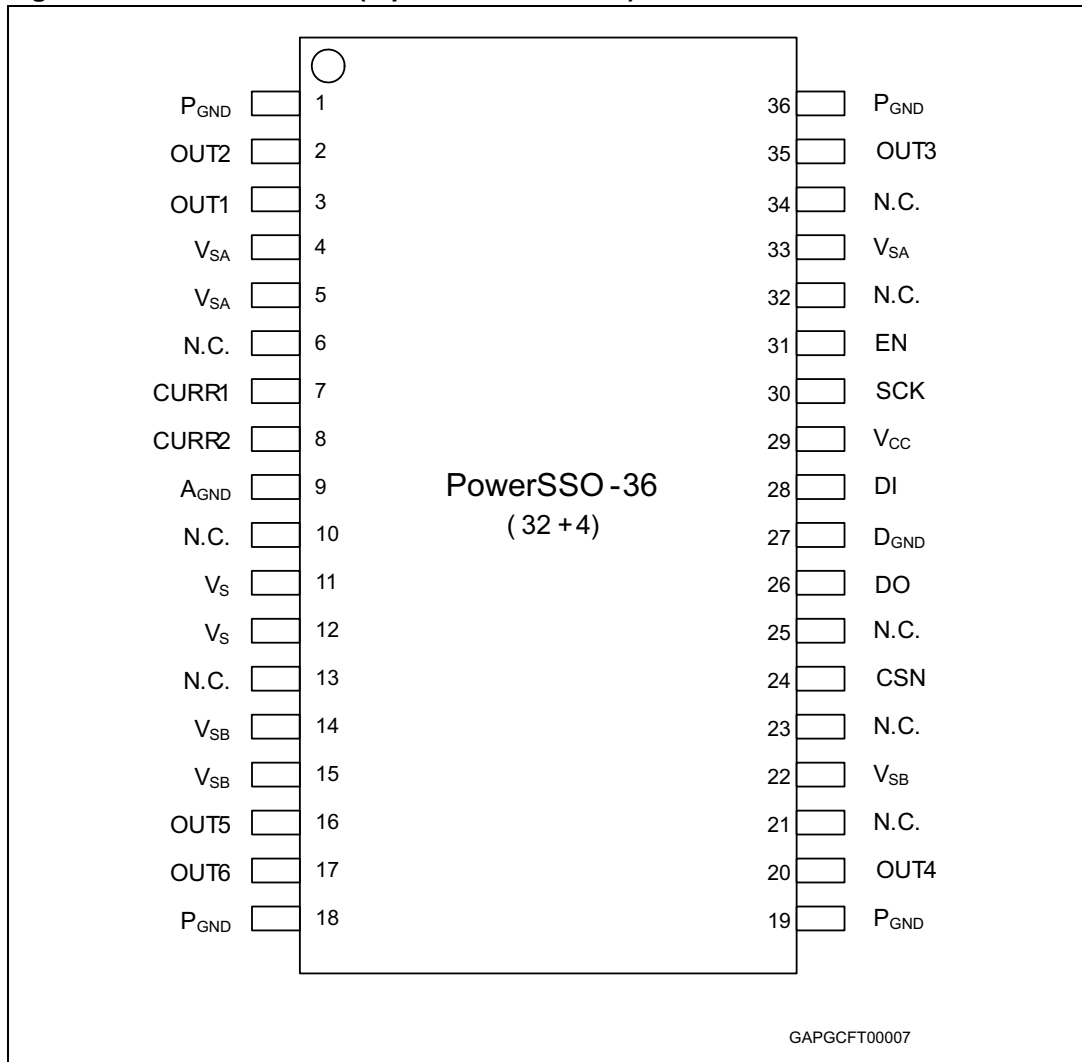

## 4 Electrical specifications

### 4.1 Absolute maximum ratings

Table 4. Absolute maximum ratings

Symbol	Parameter	Value	Unit
$V_S$	DC supply voltage	-0,3...28	V
	Single pulse $t_{max} < 400$ ms	40	V
$V_{SA}$ $V_{SB}$	DC supply voltage	-0,3...38	V
	Single pulse $t_{max} < 400$ ms	40	V
$V_{CC}$	Stabilized supply voltage, logic supply	-0.3 to 5.5	V
EN DI DO SCK CSN	Digital input / output voltage	-0.3 to $V_{CC} + 0.3$	V
CURR1/2	Current monitor output	-0.3 to $V_{CC} + 0.3$	
OUT 1-6	Output current capability	$\pm 2$	A

Note: All maximum ratings are absolute ratings. Leaving the limitation of any of these values may cause an irreversible damage of the integrated circuit!

### 4.2 ESD protection

Table 5. ESD protection

Parameter	Value	Unit
All pins	$\pm 2^{(1)}$	kV
Output pins: OUT1 – 6, $V_S$ , $V_{SA}$ , $V_{SB}$ ,	$\pm 4^{(2)}$	kV

1. HBM according to EIA/JESD22-A114-E.

2. HBM with all unzapped pins grounded.

### 4.3 Thermal data

Table 6. Operating junction temperature

Symbol	Parameter	Value	Unit
$T_j$	Operating junction temperature	-40 to 150	°C

**Table 7. Temperature warning and thermal shutdown**

Symbol	Parameter		Min.	Typ.	Max.	Unit
$T_{jTW\ ON}$	Temperature warning threshold junction temperature	$T_j$ increasing	-	-	150	°C
$T_{jSD\ ON}$	Thermal shutdown threshold junction temperature	$T_j$ increasing	-	-	170	°C

## 4.4 Electrical characteristics

$V_S = 6$  to  $18$  V,  $V_{CC} = 3.0$  to  $5.3$  V,  $T_j = -40$  to  $150$  °C, unless otherwise specified.  
The voltages are referred to GND and currents are assumed positive, when the current flows into the pin.

**Table 8. Supply**

Symbol	Parameter	Test condition	Min.	Typ.	Max.	Unit
$V_{SA}/V_{SB}$	Operating supply voltage range		6		38	V
$I_S$	$V_{SA} / V_{SB}$ DC supply current	$V_{Sx} = 13$ V, $V_{CC} = 5.0$ V EN = high Outputs floating		0.5	2	mA
$I_{VS}$	$V_S$ supply current	$V_S = 13$ V, $V_{CC} = 5$ V EN = high		1.5	4	mA
$I_{VSX}$	$V_{Sx}$ ( $V_S$ , $V_{SA}$ , $V_{SB}$ ) quiescent supply current	$V_{Sx} = 13$ V, $V_{CC} = 5$ V EN = low $T_{Test} = -40, 25$ °C Outputs floating		3	10	µA
		$T_{Test} = 130$ °C		6	20	µA
$V_{CC}$	Operating supply voltage range		3,0		5,3	V
$I_{CC}$	$V_{CC}$ DC supply current	$V_{Sx} = 13$ V, $V_{CC} = 5.0$ V EN = high		1	3	mA
	$V_{CC}$ quiescent supply current	$V_S = 13$ V, $V_{CC} = 5.0$ V CSN = $V_{CC}$ EN = low Outputs floating		5	20	µA

**Table 9. Over and undervoltage detection**

Symbol	Parameter	Test condition	Min.	Typ.	Max.	Unit
$V_{POR\ OFF}$	Power-on-reset threshold	$V_{CC}$ increasing			3.0	V
$V_{POR\ ON}$	Power-on-reset threshold	$V_{CC}$ decreasing	2.3			V
$V_{POR\ hyst}$	Power-on-reset hysteresis	$V_{POR\ OFF} - V_{POR\ ON}$		0.2		V
$V_{SUV\ OFF}$	$V_S$ UV-threshold voltage	$V_S$ increasing	6.0		6.7	V

**Table 9. Over and undervoltage detection (continued)**

Symbol	Parameter	Test condition	Min.	Typ.	Max.	Unit
$V_{SUV\ ON}$	$V_S$ UV-threshold voltage	$V_S$ decreasing	5.4		6	V
$V_{SUV\ hyst}$	$V_S$ UV-hysteresis	$V_{SUV\ OFF} - V_{SUV\ ON}$	0.35	0.5		V
$V_{SAUV\ OFF}$	$V_{SA}$ UV-threshold voltage	$V_{SA}$ increasing	5.95		6.7	V
$V_{SAUV\ ON}$	$V_{SA}$ UV-threshold voltage	$V_{SA}$ decreasing	5.4		6	V
$V_{SAUV\ hyst}$	$V_{SA}$ UV-hysteresis	$V_{SAUV\ OFF} - V_{SAUV\ ON}$	0.35	0.5		V
$V_{SBUV\ OFF}$	$V_{SB}$ UV-threshold voltage	$V_{SB}$ increasing	6.0		6.7	V
$V_{SBUV\ ON}$	$V_{SB}$ UV-threshold voltage	$V_{SB}$ decreasing	5.4		6	V
$V_{SBUV\ hyst}$	$V_{SB}$ UV-hysteresis	$V_{SBUV\ OFF} - V_{SBUV\ ON}$	0.35	0.5		V
$V_{SOV\ ON}$	$V_S$ OV-threshold voltage	$V_S$ increasing			24	V
$V_{SOV\ OFF}$	$V_S$ OV-threshold voltage	$V_S$ decreasing	18			V
$V_{SOV\ hyst}$	$V_S$ OV-hysteresis	$V_{SOV\ ON} - V_{SOV\ OFF}$	0.75	1		V

**Table 10. Switches**

Symbol	Parameter	Test condition	Min.	Typ.	Max.	Unit
$r_{ON\ HS\ 1-6}$	On resistance $V_{SA} / V_{SB}$ to OUT 1-6	$T_j = 25\ ^\circ\text{C}$ , $I_{OUT1-6} = -0.25\ \text{A}$		900	1200	m
		$T_j = 125\ ^\circ\text{C}$ , $I_{OUT1-6} = -0.25\ \text{A}$		1300	1800	m
$r_{ONLSHC\ 1-6}$	On resistance OUT 1-6 to GND in HC mode	$T_j = 25\ ^\circ\text{C}$ , HC = 1 $I_{OUT1-6} = 0.25\ \text{A}$		700	1000	m
		$T_j = 125\ ^\circ\text{C}$ , HC = 1 $I_{OUT1-6} = 0.25\ \text{A}$		1000	1500	m
$r_{ONLSLC\ 1-6}$	On resistance OUT 1-6 to GND in LC mode	$T_j = 25\ ^\circ\text{C}$ , HC = 0 $I_{OUT1-6} = 0.125\ \text{A}$		1200	1800	m
		$T_j = 125\ ^\circ\text{C}$ , HC = 0 $I_{OUT1-6} = 0.125\ \text{A}$		2000	2800	m
$I_{SCHS1-6}$	HS overcurrent protection	$V_S = 13.5\ \text{V}$	0.8		1.4	A
$I_{SCLSHC1-6}$	LS overcurrent protection in HC mode	$V_S = 13.5\ \text{V}$ , HC=1	0.8		1.4	A
$I_{SCLS1-6}$	LS overcurrent protection in LC mode	$V_S = 13.5\ \text{V}$ , HC=0	0.4		0.7	A
$t_{d\ ON1-6\ H}$	Output delay time, HS switch on	$V_S = 13.5\ \text{V}$ , $R_{load} = 52$	10	25	80	$\mu\text{s}$
$t_{d\ OFF1-6\ H}$	Output delay time, HS switch off	$V_S = 13.5\ \text{V}$ , $R_{load} = 52$	50	100	300	$\mu\text{s}$
$t_{d\ ON1-6\ L}$	Output delay time, LS switch on	$V_S = 13.5\ \text{V}$ , $R_{load} = 52$	5	15	80	$\mu\text{s}$
$t_{d\ OFF1-6\ L}$	Output delay time, LS switch off	$V_S = 13.5\ \text{V}$ , $R_{load} = 52$	50	100	300	$\mu\text{s}$

**Table 10. Switches (continued)**

Symbol	Parameter	Test condition	Min.	Typ.	Max.	Unit
$t_{D\ LH}/t_{D\ HL}$	Cross current protection time		20	200	400	$\mu s$
$I_{QLH}$	Switched-off output current HS OUT 1-6	$V_{OUT1-6} = 0\ V$	-2			$\mu A$
$I_{QLL}$	Switched-off output current LS OUT 1-6	$V_{OUT1-6} = V_S$			2	$\mu A$
$I_{OLDHS1-6}$	Open-load detection current HS OUT 1-6	$T_{amb} = -40\ ^\circ C$	8	30	60	mA
		$T_{amb} = 25\ ^\circ C$ to $125\ ^\circ C$	10	30	60	mA
$I_{OLDLSHC1-6}$	Open-load detection current LS OUT 1-6 in HC mode	HC bit set to 1; $T_{amb} = -40\ ^\circ C$	4.5	30	65	mA
		HC bit set to 1; $T_{amb} = 25\ ^\circ C$ to $125\ ^\circ C$	8	30	60	mA
$I_{OLDLSLC1-6}$	Open-load detection current LS OUT 1-6 in LC mode	HC bit set to 0; $T_{amb} = -40\ ^\circ C$	1.8	15	35	mA
		HC bit set to 0; $T_{amb} = 25\ ^\circ C$ to $125\ ^\circ C$	4	15	30	mA
$t_{dOL}$	Minimum duration of open-load condition to set the status bit		500	2000	3000	$\mu s$
$t_{ISC}$	Minimum duration of overcurrent condition to switch off the driver		10	32	100	$\mu s$
$dV_{OUT1-6}/dt$	Slew rate of OUT 1-6	$V_S = 13.5\ V, R_{load} = 52$	0.1	0.25	0.5	V/ $\mu s$

**Figure 4. Output turn-on/off delays and slew rates**

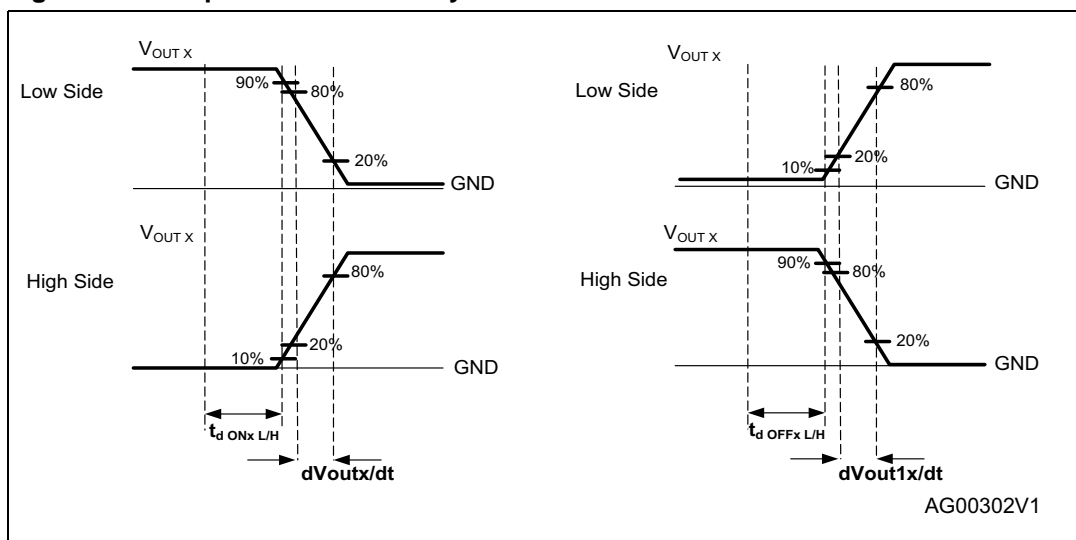



Table 11. Current monitor output

Symbol	Parameter	Test condition	Min.	Typ.	Max.	Unit
$V_{CURRE1/2}$	Functional voltage range	$V_{CC} = 5\text{ V}$	0		$V_{CC} - 1$	V
$I_{CURRHLS250}$	HS/LS current monitor output ratio: $I_{CURRE1/2} / I_{OUT\ 1-6}$	$0\text{ V} \leq V_{CURRE1/2} \leq V_{CC} - 1\text{ V}$ , $V_{CC} = 5\text{ V}$ ; prog. via SPI, $I_{max} = 800\text{ mA}$		1/250		
$I_{CURRHLS500}$	HS/LS current monitor output ratio: $I_{CURRE1/2} / I_{OUT\ 1-6}$	$0\text{ V} \leq V_{CURRE1/2} \leq V_{CC} - 1\text{ V}$ , $V_{CC} = 5\text{ V}$ ; prog. via SPI, $I_{max} = 800\text{ mA}$		1/500		
$I_{CURRHLS750}$	HS/LS current monitor output ratio: $I_{CURRE1/2} / I_{OUT\ 1-6}$	$0\text{ V} \leq V_{CURRE1/2} \leq V_{CC} - 1\text{ V}$ , $V_{CC} = 5\text{ V}$ ; prog. via SPI, $I_{max} = 800\text{ mA}$		1/750		
$I_{CURRHLS1000}$	HS/LS current monitor output ratio: $I_{CURRE1/2} / I_{OUT\ 1-6}$	$0\text{ V} \leq V_{CURRE1/2} \leq V_{CC} - 1\text{ V}$ , $V_{CC} = 5\text{ V}$ ; prog. via SPI, $I_{max} = 800\text{ mA}$		1/1000		
$I_{CURRLSLC125}$	LS current monitor output ratio in LC mode: $I_{CURRE1/2} / I_{OUT\ 1-6}$	$0\text{ V} \leq V_{CURRE1/2} \leq V_{CC} - 1\text{ V}$ , $V_{CC} = 5\text{ V}$ ; prog. via SPI, HC=0; $I_{max} = 400\text{ mA}$		1/125		
$I_{CURRLSLC250}$	LS current monitor output ratio in LC mode: $I_{CURRLSLC1/2} / I_{OUT\ 1-6}$	$0\text{ V} \leq V_{CURRE1/2} \leq V_{CC} - 1\text{ V}$ , $V_{CC} = 5\text{ V}$ ; prog. via SPI, HC=0; $I_{max} = 400\text{ mA}$		1/250		
$I_{CURRLSLC375}$	LS current monitor output ratio in LC mode: $I_{CURRE1/2} / I_{OUT\ 1-6}$	$0\text{ V} \leq V_{CURRE1/2} \leq V_{CC} - 1\text{ V}$ , $V_{CC} = 5\text{ V}$ ; prog. via SPI, HC = 0; $I_{max} = 400\text{ mA}$		1/375		
$I_{CURRLSLC500}$	LS current monitor output ratio in LC mode: $I_{CURRE1/2} / I_{OUT\ 1-6}$	$0\text{ V} \leq V_{CURRE1/2} \leq V_{CC} - 1\text{ V}$ , $V_{CC} = 5\text{ V}$ ; prog. via SPI, HC = 0; $I_{max} = 400\text{ mA}$		1/500		
$I_{CURRHLS1/2\ acc}$	HS current monitor accuracy	$0\text{ V} \leq V_{CURRE1/2} \leq V_{CC} - 1\text{ V}$ , $V_{CC} = 5\text{ V}$ ; $I_{OUT\ 1-6\ max} = 0.8\text{ A}$ ; (FS = full scale = 800 mA*current ratio); $T_j = -40\text{ }^\circ\text{C}$		4% + 1%FS	10% + 3%FS	-
		$0\text{ V} \leq V_{CURRE1/2} \leq V_{CC} - 1\text{ V}$ , $V_{CC} = 5\text{ V}$ ; $I_{OUT\ 1-6\ max} = 0.8\text{ A}$ ; (FS = full scale = 800 mA*current ratio); $T_j = 25\text{ }^\circ\text{C}$ to $125\text{ }^\circ\text{C}$		4% + 1%FS	8% + 2%FS	
$I_{CURRLSHC1/2\ acc}$	LS current monitor accuracy in HC mode	$0\text{ V} \leq V_{CURRE1/2} \leq V_{CC} - 1\text{ V}$ ; $V_{CC} = 5\text{ V}$ ; $0.4\text{ A} \leq I_{OUT\ 1-6} \leq 0.8\text{ A}$ ; (FS = full scale = 800 mA*current ratio)		4% + 1%FS	10% + 3%FS	-
$I_{CURRLSLC1/2\ acc}$	LS current monitor accuracy in LC mode	$0\text{ V} \leq V_{CURRE1/2} \leq V_{CC} - 1\text{ V}$ ; $V_{CC} = 5\text{ V}$ ; $I_{OUT\ 1-6\ max} = 0.4\text{ A}$ ; (FS = full scale = 800 mA*current ratio)		4% + 1%FS	10% + 3%FS	-

**Table 12. Current monitor dynamic characteristics**

Symbol	Parameter	Test condition	Min.	Typ.	Max.	Unit
$t_{d-CM}$	Output to current monitor delay time	$I_{OUT}$ from 100 mA to 200 mA; $t_{d-CM}$ measured from 50% $I_{OUT}$ to 50% ICM	—	2	—	$\mu s$

**Table 13. Oscillator**

Symbol	Parameter	Test condition	Min.	Typ.	Max.	Unit
$f_{CLK}$	Internal clock frequency		2.8	4	5.2	MHz

## 5 SPI electrical characteristics

$V_S = 6$  to  $18$  V,  $V_{CC} = 3.0$  to  $5.3$  V,  $T_j = -40$  to  $150$  °C, unless otherwise specified.  
The voltages are referred to GND and currents are assumed positive, when the current flows into the pin

**Table 14. DC characteristics**

Symbol	Parameter	Test condition	Min.	Typ.	Max.	Unit
<b>SDI, SCK, CSN, EN</b>						
$V_{IL}$	Input low voltage				$0.3 V_{CC}$	V
$V_{IH}$	Input high voltage		$0.7 V_{CC}$			V
$I_{CSN\ in}$	Pull up current at input CSN	$V_{CSN} = 1.5$ V; $V_{CC} = 5$ V	8	20	40	$\mu$ A
$I_{SCK\ in}$	Pull down current at input SCK	$V_{SCK} = 1.5$ V; $V_{CC} = 5$ V	10	25	50	$\mu$ A
$I_{DI\ in}$	Pull down current at input DI	$V_{DI} = 1.5$ V; $V_{CC} = 5$ V	10	25	50	$\mu$ A
$R_{EN\ in}$	Pull down resistor at input EN	$V_{EN} = 1.5$ V; $V_{CC} = 5$ V	25	50	115	k
<b>SDO</b>						
$V_{OL}$	Output low voltage	$I_{out} = 2$ mA		0.2	0.4	V
$V_{OH}$	Output high voltage	$I_{out} = +2$ mA	$V_{CC} - 0.4$	$V_{CC} - 0.2$		V
$I_{DOLK}$	3-state leakage current	$V_{CSN} = V_{CC}$ , $0$ V < $V_{CC}$	-10		10	$\mu$ A

**Table 15. AC characteristics**

Symbol	Parameter	Test condition	Min.	Typ.	Max.	Unit
<b>SDO, SDI, SCK, CSN, EN</b>						
$C_{OUT}^{(1)}$	Output capacitance (SDO)	$V_{OUT} = 0$ V to $5$ V	-	-	10	pF
$C_{IN}$	Input capacitance (SDI)	$V_{IN} = 0$ V to $5$ V	-	-	10	pF
	Input capacitance (other pins)	$V_{IN} = 0$ V to $5$ V	-	-	10	pF

1. Guaranteed by design.

**Table 16. Dynamic characteristics<sup>(1)</sup>**

Symbol	Parameter	Test condition	Min.	Typ.	Max.	Unit
$t_{EN}$	EN high setup time				100	$\mu$ s
$t_{SCSN}$	CSN setup time before SCK rising		400			ns
$t_{HCSN}$	CSN high time		2			$\mu$ s

Table 16. Dynamic characteristics<sup>(1)</sup> (continued)

Symbol	Parameter	Test condition	Min.	Typ.	Max.	Unit
$t_{CSNQV}$	CSN falling until SDO valid	$C_{OUT} = 100 \text{ pF}$			100	ns
$t_{CSNQT}$	CSN rising until SDO 3-state	$C_{OUT} = 100 \text{ pF}$			150	ns
$t_{SSCK}$	SCK setup time before CSN rising		50			ns
$t_{SSDI}$	SDI setup time before SCK rising		40			ns
$t_{HSCK}$	SCK high time		200			ns
$t_{LSCK}$	SCK low time		200			ns
$t_{SCKQV}$	SCK falling until SDO valid	$C_{out} = 100 \text{ pF}$			150	ns
$t_{QLQH}$	Output rise time	$C_{out} = 100 \text{ pF}$ 20 % - 80 % $V_{CC}$			110	ns
$t_{QHQL}$	Output fall time	$C_{out} = 100 \text{ pF}$ 20 % - 80 % $V_{CC}$			110	ns
$f_{SPI}$	SPI frequency				1	MHz

1. See [Section 5.1: SPI timing parameter definition](#)

### 5.1 SPI timing parameter definition

Figure 5. SPI timing

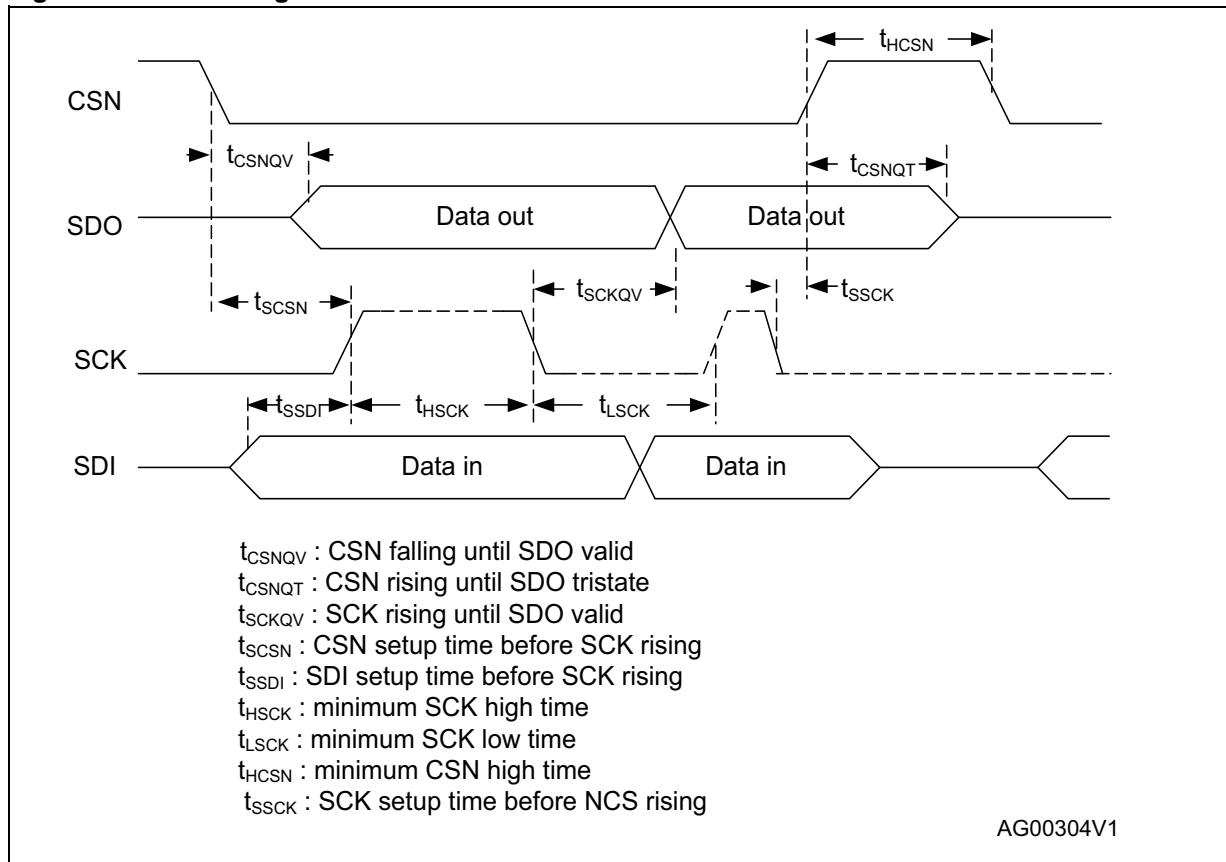
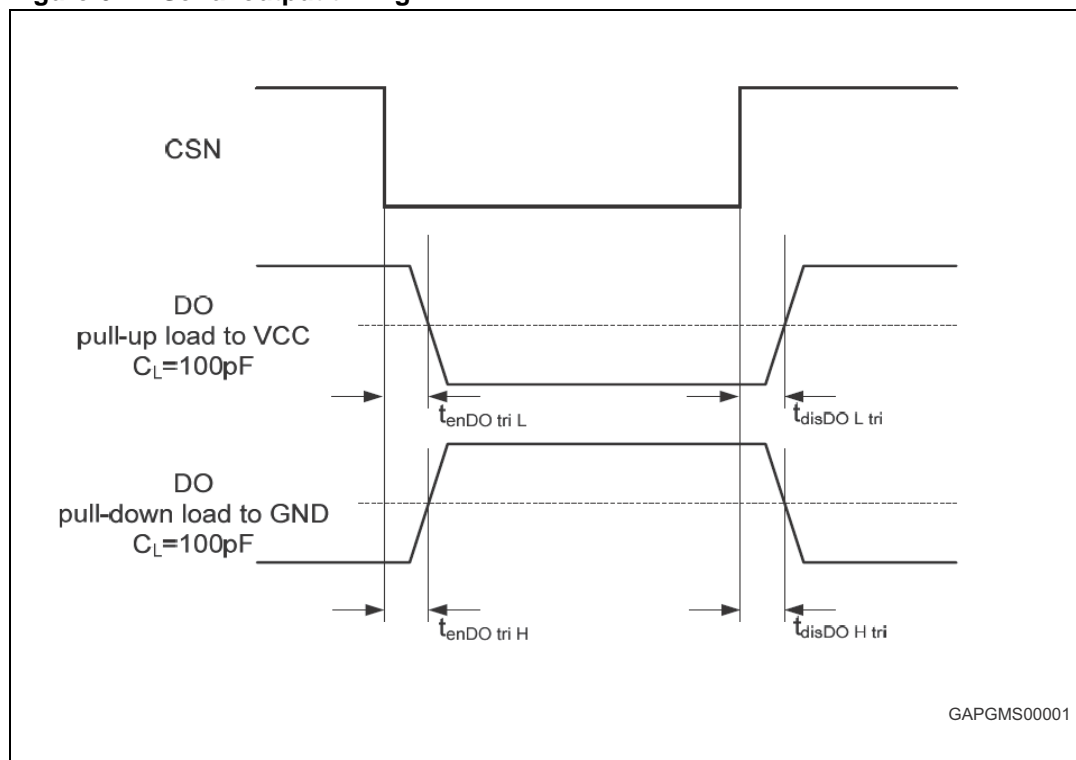

Figure 6. Serial output timing



## 6 Functional description of the SPI

### 6.1 Signal description

#### 6.1.1 Serial clock (SCK)

This input signal provides the timing of the serial interface. Data present at Serial Data Input (SDI) is latched on the rising edge of Serial Clock (SCK). Data on Serial Data Out (SDO) is shifted out at the falling edge of serial clock (see [Figure 7](#)). The SPI can be driven by a microcontroller with its SPI peripherals running in following mode: CPOL = 0 and CPHA = 0 (see [Figure 7](#)).

#### 6.1.2 Serial data input (SDI)

This input is used to transfer data serially into the device. It receives the data to be written. Values are latched on the rising edge of Serial Clock (SCK).

#### 6.1.3 Serial data output (SDO)

This output signal is used to transfer data serially out of the device. Data is shifted out on the falling edge of Serial Clock (SCK). SDO also reflects the status of the <Global Error Flag> (Bit 7 of the <Global Status Register>) while CSN is low and no clock signal is present

#### 6.1.4 Chip select not (CSN)

When this input signal is High, the device is deselected and Serial Data Output (SDO) is high impedance (3-state). Driving this input low enables the communication. The communication must start and stop on a low level of Serial Clock (SCK).

**Figure 7. Clock polarity and clock phase**

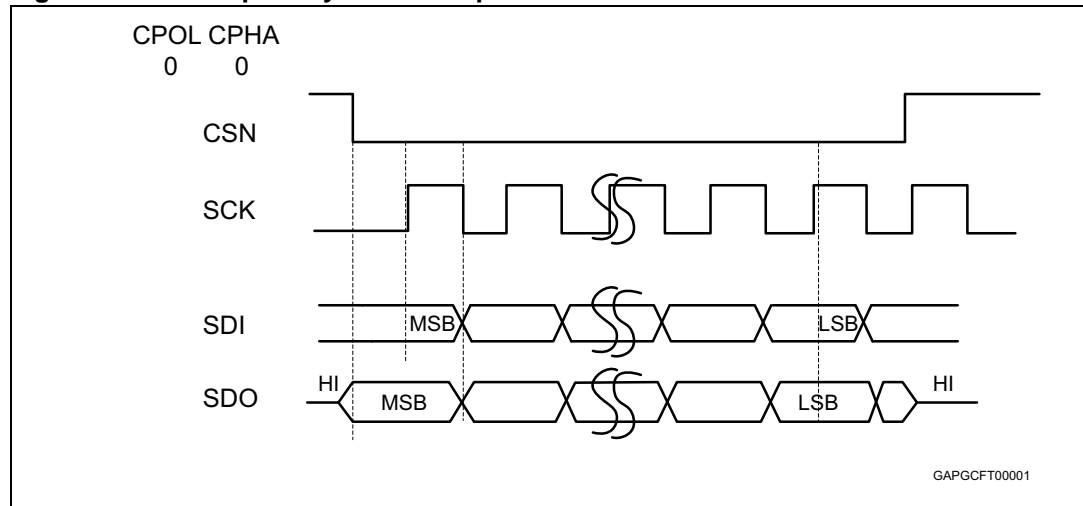
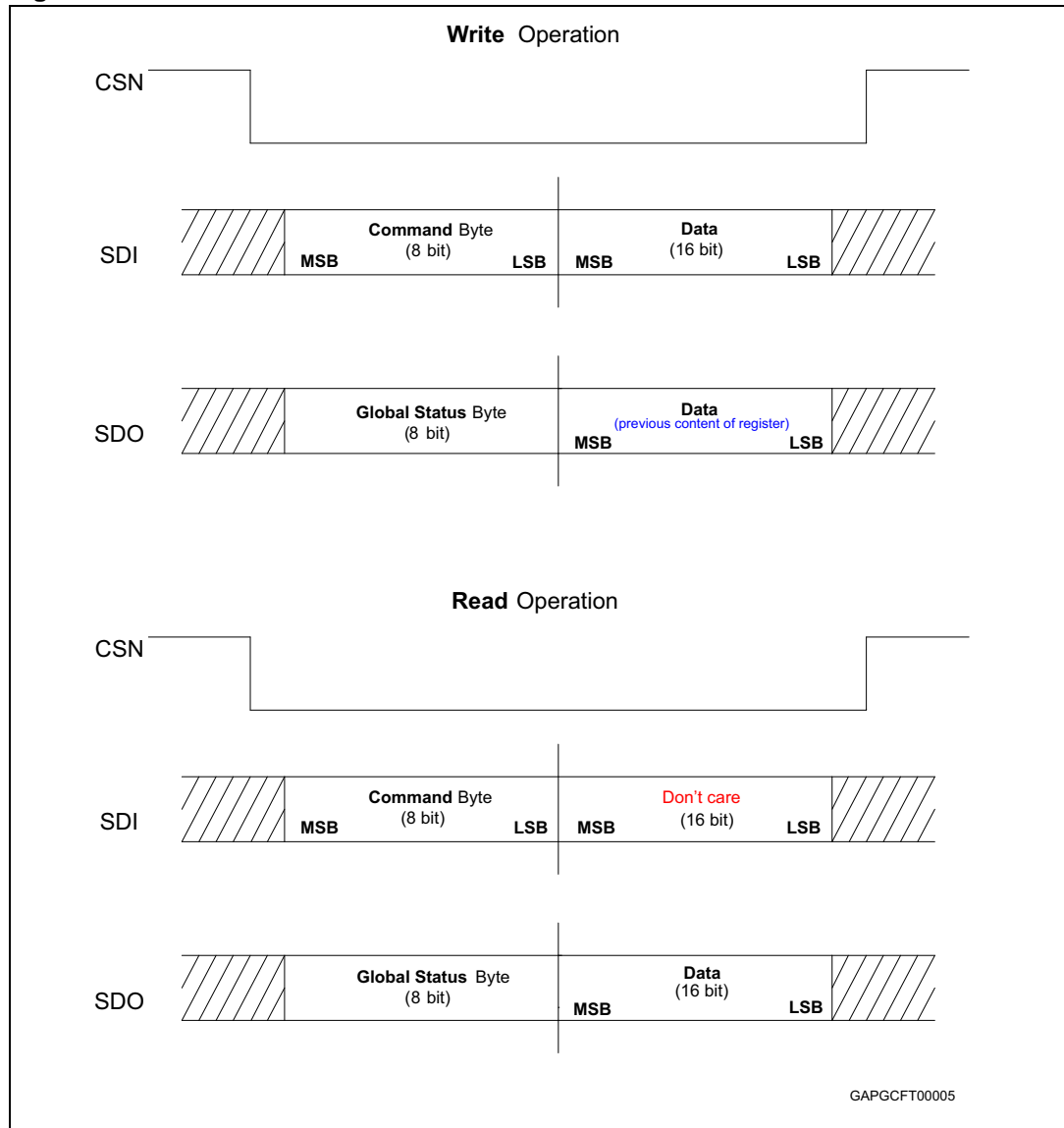

Figure 8. SPI frame structure



## 6.2 SPI communication flow

### 6.2.1 General description

The proposed SPI communication is based on a standard SPI interface structure using CSN (Chip Select Not), SDI (Serial Data In), SDO (Serial Data Out/Error) and SCK (Serial Clock) signal lines. Maximum SPI frequency is 1 MHz.

At the beginning of each communication the master reads the <SPI-frame-ID> register (ROM address 3EH) of the slave device. This 8-bit register indicates the SPI frame length (24 bit for the L99MD02) and the availability of additional features.

Each communication frame consists of an instruction byte which is followed by 2 data bytes (Figure 8).



The data returned on SDO within the same frame always starts with the <Global Status> register. It provides general status information about the device. It is followed by 2bytes (i.e. 'In-frame-response', [Figure 8](#)).

For write cycles the <Global Status> register is followed by the previous content of the addressed register.

For read cycles the <Global Status> register is followed by the content of the addressed register.

**Table 17. Command byte (8 bit)**

	Operating code		Address					
Bit	23	22	21	20	19	18	17	16
Name	OC1	OC0	A5	A4	A3	A2	A1	A0

**Table 18. Data byte**

	Data Byte 1								Data Byte 0							
Bit	15	14	13	12	11	10	9	8	7	6	5	4	3	2	1	0
Name	D15	D14	D13	D12	D11	D10	D9	D8	D7	D6	D5	D4	D3	D2	D1	D0

## 6.2.2 Command byte

Each communication frame starts with a command byte. It consists of an operating code which specifies the type of operation (<Read>, <Write>, <Read and Clear Status>, <Read Device Information>) and a 6 bit address.

**Table 19. Operating code definition**

OC1	OC0	Meaning
0	0	<Write mode>
0	1	<Read mode>
1	0	<Read and clear status>
1	1	<Read device information>

The <Write Mode> and <Read Mode> operations allow access to the RAM of the device, i.e. write to control registers or read status information.

A <Read and Clear Status> Operation addressed to a device specific status register will read back and subsequently clear this status register. A <Read and Clear Status> Operation with address 3FH clears all status registers at a time and reads back the <Configuration> register.

A <Read and Clear Status> operation addressed to an unused RAM address register will be identical to a <Read Mode> operation (in case of unused RAM address, the second byte will be equal to 00H).

<Read Device Information> allows access to the ROM area which contains device related information such as the product family, product name, silicon version and register width.

**Table 20. Global status byte**

Bit	Description	Polarity	Comment						
0	Software reset or under/ overvoltage	Active high	Depend on bit 5 of <Global Status Byte>:						
			<table border="1"> <thead> <tr> <th>Bit 5</th> <th>Bit 0</th> </tr> </thead> <tbody> <tr> <td>0</td> <td>Set if software reset (SDI stuck at 1 or 0)</td> </tr> <tr> <td>1</td> <td>Logical OR of the under- / overvoltage status bits</td> </tr> </tbody> </table>	Bit 5	Bit 0	0	Set if software reset (SDI stuck at 1 or 0)	1	Logical OR of the under- / overvoltage status bits
			Bit 5	Bit 0					
0	Set if software reset (SDI stuck at 1 or 0)								
1	Logical OR of the under- / overvoltage status bits								
1	Overcurrent detected	Active high	Set by any overcurrent event						
2	Open-load detected	Active high	Set by any open-load event						
3	Temp warning	Active high							
4	Thermal shutdown / chip overload	Active high							
5	NOT (chip reset or communication error)	Active low	Activated by all internal reset events that change device state or configuration registers (e.g. software reset, V <sub>CC</sub> under-voltage, etc.). The bit will be set after a valid communication with any register. This bit is initially '0' and will be set to '1' by a valid SPI communication						
6	Communication error	Active high	Bit is set if the number of clock cycles during CSN = low does not match with the specified frame width or if an invalid bus condition is detected (SDI stuck at 1 or 0).						
7	Global error flag	Active high	Logic OR combination of all failures in the <Global Status Byte>.						

The <Global Error Flag> is generated by an OR-combination of all failure events of the device (i.e. Bit 0 to Bit 6 of the <Global Status Byte>).

Figure 9. Indication of the global error flag on SDO when CSN is low and SCK is stable

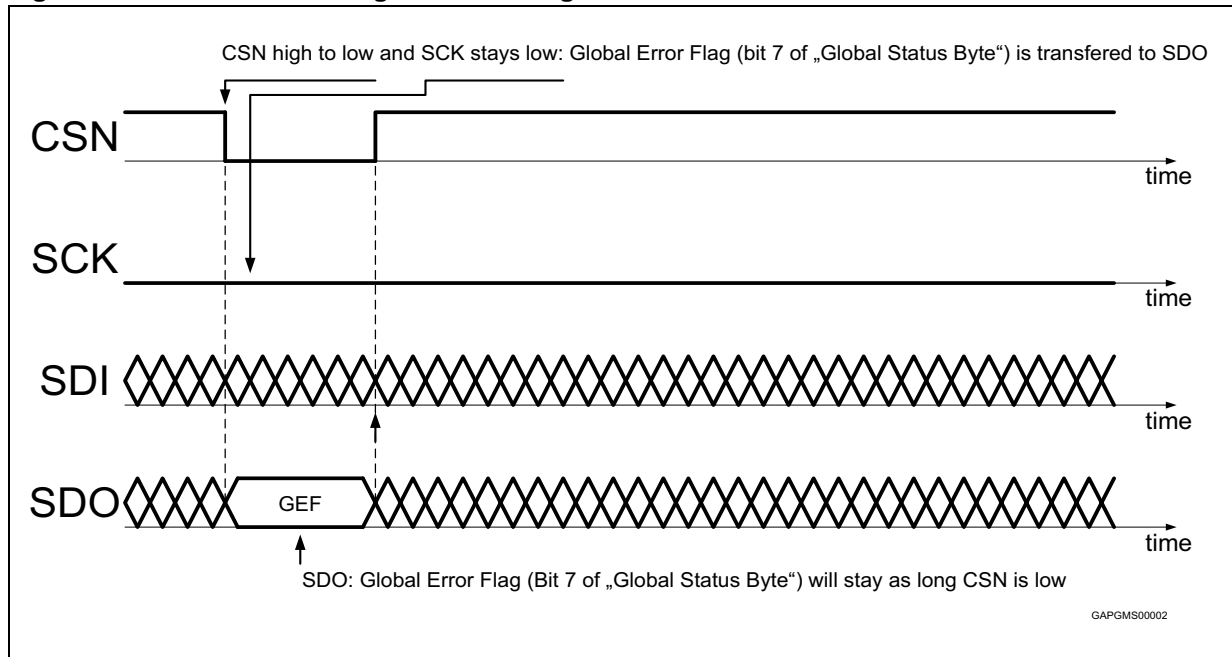

The bit 0 of the <Global Status Byte> is a combination of an under/overvoltage warning and a software warning: If the bit 5 is one (this is the standard after a correct SPI communication), bit 0 is the logical OR of all under- and overvoltage status bits.

On the other hand, if there has been an SPI communication error or a chip reset (bit 5 is zero), then bit 0 gives a better indication about the SPI error: An SDI stuck-at error will lead to a software reset and will set bit 0, while a clock pulse error only sets the communication error bit, clears bit 5 and will clear also bit 0. This leads to the following table of possible states (assuming there is no under/overvoltage, overcurrent, openload or thermal error):

Table 21. Reset

State	Description	Global status
EN = 0 (Power on reset)	All registers reset Outputs switched off (3-state)	1000 0000
Clock cycles != 24	Ignore frame No reset	1100 0000
SDI always 0	Software reset Outputs switched off	1100 0001
SDI always 1	Software reset Outputs switched off	1100 0001

Writing to the selected data input register is only enabled if exactly one frame length is transmitted within one communication frame (i.e. CSN low). If more or less clock pulses are counted within one frame, the complete frame will be ignored and a SPI frame error is signaled in the Global Status register. This safety function is implemented to avoid an unwanted activation of output stages by a wrong communication frame.

For read operations, the *<communication error>* bit in the *<Global Status Byte>* will be set, but the register to be read will still be transferred to the SDO pin. If the number of clock cycles is smaller than the frame width, the data at SDO will be truncated. If the number of clock cycles is larger than the frame width, the data at SDO will be filled with '0' bits.

Due to this safety functionality a daisy chaining of SPI is not possible. Instead, a parallel operation of the SPI bus by controlling the CSN signal of the connected ICs is recommended.

*Note:* As the frame width is 24 bits, an initial read of *<SPI-frame-ID>* using a 16 bits communication will set the *<communication Error bit>* of the *<Global Status Byte>*. A subsequent correct length transaction is necessary to correct this bit.

### 6.3 Write operation

OC0, OC1: operating code (00 for 'write' mode).

The write operation starts with a command byte followed by 2 data bytes.

For write cycles the *<Global Status>* register is followed by the previous content of the addressed register.

The RAM memory area consists of 16 bit registers. All unused RAM addresses will be read as '0'.

Failures are indicated by activating the corresponding bit of the *<Global Status>* register.

*Note:* RAM address 00H is unused. An attempt to access this address is recognized as a communication line error ('Data-in stuck to GND') and all internal registers will be cleared (software reset).

### 6.4 Read operation

OC0, OC1: operating code (01 for 'read' mode).

The read operation starts with a command byte followed by 2 data bytes. The content of the data bytes is 'don't care'. The content of the addressed register is shifted out at SDO within the same frame ('inframe response'). The returned data byte represents the content of the register to be read. Failures are indicated by activating the corresponding bit of the *<Global Status>* register.

### 6.5 Read and clear status operation

OC0, OC1: operating code (10 for 'read and clear status' mode).

The 'Read and Clear Status' operation starts with a command byte followed by 2 data bytes.

The content of the data bytes is 'don't care'. The content of the addressed status register is transferred to SDO within the same frame ('in-frame response') and is subsequently cleared.

A 'Read and Clear Status' operation with address 3FH clears all Status registers simultaneously.

A <Read and Clear Status> operation addressed to an unused RAM address will be identical to a <Read Mode> operation (in case of unused RAM address, the second byte will be equal to 00H).

The returned data byte represents the content of the register to be read.

Failures are indicated by activating the corresponding bit of the <Global Status> register.

## 6.6 Read device information

OC0, OC1: operating code (11 for 'read device information mode')

The device information is stored at the ROM. In the ROM memory area, the first 8 bits are used. All unused ROM addresses will be read as '0'.

*Note: ROM address 3FH is unused. An attempt to access this address is recognized as a communication line error ('Data-in stuck to Vcc') all internal registers will be cleared (software reset).*

## 7 SPI control and status register

**Table 22. RAM memory map**

Address	Name	Access	Content
01h	Control register 1	Read/write	Output switch on/off
02h	Control register 2	Read/write	Not used
03h	Control register 3	Read/write	Low side high current mode V <sub>S</sub> configuration
04h	Control register 4	Read/write	Current multiplexer
05h	Control register 5	Read/write	PWM
06h	Control register 6	Read/write	Open-load
10h	Status register 0	Read only	Overcurrent
11h	Status register 1	Read only	Open-load
12h	Status register 2	Read only	TSD Over/undervoltage

**Table 23. ROM memory map (access with OC0 and OC1 set to '1')**

Address	Name	Access	Content
00h	ID header	Read only	43h (device class ASSP, 2 additional information bytes)
01h	Version	Read only	00h (engineering samples) (ST-SPI)
02h	ProducCode1	Read only	3Eh (62 ST_SPI)
03h	ProducCode2	Read only	4Eh (N ST_SPI)
3Dh	Fuses	Read only	Fuse data 9 -0
3Eh	SPI-Frame ID	Read only	02h SPI-Frame-ID Register (24 Bit ST_SPI)

Table 24. Control status register<sup>(1)</sup>

Address	Access	Data byte 1								Data byte 0								
<b>Output switch on/off</b>																		
		15	14	13	12	11	10	9	8	7	6	5	4	3	2	1	0	
01h	R/W	0	0	HS4	LS4	HS6	LS6	HS5	LS5	0	0	HS3	LS3	HS2	LS2	HS1	LS1	
<b>Not used</b>																		
		15	14	13	12	11	10	9	8	7	6	5	4	3	2	1	0	
02h	R/W	0	0	0	0	0	0	0	0	0	0	0	0	0	0	0	0	
<b>Low side high current (reset value = 1)</b>																		
		15	14	13	12	11	10	9	8	7	6	5	4	3	2	1	0	
03h	R/W	0	HC4	HC6	HC5	0	HC3	HC2	HC1	0	V <sub>S</sub> OV warn/ shutdown	0	0	0	0	0	0	
<b>Current multiplexer</b>																		
		15	14	13	12	11	10	9	8	7	6	5	4	3	2	1	0	
04h	R/W	OUTx to CURR2	OUTx to CURR2	OUTx to CURR2	Enable CURR2	OUTx to CURR1	OUTx to CURR1	OUTx to CURR1	Enable CURR1	0	0	0	0	2Kfact	2Kfact	1Kfact	1Kfact	
<b>PWM</b>																		
		15	14	13	12	11	10	9	8	7	6	5	4	3	2	1	0	
05h	R/W	0	0	0	0	0	0	PWM duty	0	0	OUT4	OUT6	OUT5	0	OUT3	OUT2	OUT1	
<b>Open-load</b>																		
		15	14	13	12	11	10	9	8	7	6	5	4	3	2	1	0	
06h	R/W	0	0	0	0	0	0	0	0	0	Disable OL4	Disable OL6	Disable OL5	0	Disable OL3	Disable OL2	Disable OL1	
<b>Status overcurrent</b>																		
		15	14	13	12	11	10	9	8	7	6	5	4	3	2	1	0	
10h	R	0	0	HS4	LS4	HS6	LS6	HS5	LS5	0	0	HS3	LS3	HS2	LS2	HS1	LS1	
<b>Status open-load</b>																		
		15	14	13	12	11	10	9	8	7	6	5	4	3	2	1	0	
11h	R	0	0	0	0	0	0	0	0	0	0	OUT4	OUT6	OUT5	0	OUT3	OUT2	OUT1
<b>Status TSD; over/undervoltage</b>																		
		15	14	13	12	11	10	9	8	7	6	5	4	3	2	1	0	
12h	R	0	0	0	0	0	0	0	0	TSD	TSD warm	0	0	V <sub>S</sub> UV	V <sub>S</sub> OV	V <sub>SB</sub> UV	V <sub>SA</sub> UV	

1. Default reset value is 0, all unused bits read 0, unused bits have to be set to 0.

**Table 25. Control register 1 (read/write); address 01h**

Bit	Name	Comment
15		<p>If a bit is set, the selected output driver is switched on. If the corresponding PWM enable bit is set the driver will be PWMed.</p> <p>If the bits of HS-and LS-driver of the same half bridge are set, the HS and the LS-driver will be deactivated.</p>
14		
13	OUT4 – HS on/off	
12	OUT4 – LS on/off	
11	OUT6 – HS on/off	
10	OUT6 – LS on/off	
9	OUT5 – HS on/off	
8	OUT5 – LS on/off	
7		
6		
5	OUT3 – HS on/off	
4	OUT3 – LS on/off	
3	OUT2 – HS on/off	
2	OUT2 – LS on/off	
1	OUT1 – HS on/off	
0	OUT1 – LS on/off	

**Table 26. Control register 3 (read/write); address 03h**

Bit	Name	Comment
15		<p>High current mode of low side switch</p> <p>“0”: the selected low side switch is in low current mode. The overcurrent and open-load thresholds are reduced by ½. The selected current monitor ratio is doubled.</p> <p>“1” (default setting) the selected low side switch is in high current mode.</p>
14	High current LS 4	
13	High current LS 6	
12	High current LS 5	
11		
10	High current LS 3	
9	High current LS 2	
8	High current LS 1	
7	-	
6	V <sub>S</sub> OV shutdown/warn	<p>In case of V<sub>S</sub> overvoltage</p> <p>“0”: all outputs will be switched off + status bit set.</p> <p>“1”: only status bit will be set.</p>
5		
4		
3		



**Table 26. Control register 3 (read/write); address 03h (continued)**

Bit	Name	Comment
2		
1		
0		

**Table 27. Control register 4 (read/write); address 04h**

Bit	Name	Comment								
15	OUTx to CURR2 Bit2	Bit setting	111	110	101	100	011	010	001	000
14	OUTx to CURR2 Bit1	To curr2		OUT4	OUT6	OUT5		OUT3	OUT2	OUT1
13	OUTx to CURR2 Bit0									
12	Enable CURR2	Enable the current monitor output 2								
11	OUTx to CURR1 Bit2	Bit setting	111	110	101	100	011	010	001	000
10	OUTx to CURR1 Bit1	To curr1		OUT4	OUT6	OUT5		OUT3	OUT2	OUT1
9	OUTx to CURR1 Bit0									
8	Enable CURR1	Enable the current monitor output 1								
7	-									
6	-									
5	-									
4	-									
3	Curr2 K-factor	Current monitor ratio $I_{OUTx}/I_{CURR}$ If the high current bit (register 03h) is set to 0 the ratio for the low side will be the double of the programmed one.								
2	Curr2 K-factor									
1	Curr1 K-factor									
0	Curr1 K-factor									

**Table 28. Ratio for CURR2**

Bit3	Bit2	Ratio for CURR2
0	0	1/1000
0	1	1/750
1	0	1/500
1	1	1/250

**Table 29. Ratio for CURR1**

Bit1	Bit0	Ratio for CURR1
0	0	1/1000
0	1	1/750
1	0	1/500
1	1	1/250

**Table 30. Control register 5 (read/write); address 05h**

Bit	Name	Comment															
15	-																
14	-																
13	-																
12	-	<table border="1"> <thead> <tr> <th>Bit 9</th> <th>Bit 8</th> <th>PWM duty cycle</th> </tr> </thead> <tbody> <tr> <td>0</td> <td>0</td> <td>15 %</td> </tr> <tr> <td>0</td> <td>1</td> <td>30 %</td> </tr> <tr> <td>1</td> <td>0</td> <td>45 %</td> </tr> <tr> <td>1</td> <td>1</td> <td>60 %</td> </tr> </tbody> </table>	Bit 9	Bit 8	PWM duty cycle	0	0	15 %	0	1	30 %	1	0	45 %	1	1	60 %
Bit 9	Bit 8	PWM duty cycle															
0	0	15 %															
0	1	30 %															
1	0	45 %															
1	1	60 %															
11	-																
10	-																
9	PWM duty Bit1																
8	PWM duty Bit0																
7	-																
6	PWM to OUT4	PWM enable: – “0”: PWM disabled this output – “1”: if the corresponding enable bit is set and the PWM bit is set to “1” the programmed output will be PWM’ed with typical 100 Hz															
5	PWM to OUT6																
4	PWM to OUT5																
3	-																
2	PWM to OUT3																
1	PWM to OUT2																
0	PWM to OUT1																

**Table 31. Control register 6 (read/write); address 06h**

Bit	Name	Comment
15	-	Disable the open-load measurement "0": open-load is signaled via the corresponding bit in status register 2 and the global error byte. "1": in case of an open-load, no register will change. Also the global error register will not change.
14	-	
13	-	
12	-	
11	-	
10	-	
9	-	
8	-	
7		
6	Disable OL OUT4	
5	Disable OL OUT6	
4	Disable OL OUT5	
3		
2	Disable OL OUT3	
1	Disable OL OUT2	
0	Disable OL OUT1	

**Table 32. Status register 0 (read only); address 10h**

Bit	Name	Comment
15	-	Overcurrent error detected, driver will be deactivated
14	-	
13	HS4	
12	LS4	
11	HS6	
10	LS6	
9	HS5	
8	LS5	
7	-	
6	-	
5	HS3	
4	LS3	
3	HS2	
2	LS2	
1	HS1	
0	LS1	

**Table 33. Status register 1 (read only); address 11h**

Bit	Name	Comment
15-8	-	-
7	-	Open-load detected, information only no changes if the corresponding disable OL bit (control register 6) is set
6	Open-load Out4	
5	Open-load Out6	
4	Open-load Out5	
3		
2	Open-load Out3	
1	Open-load Out2	
0	Open-load Out1	

**Table 34. Status register 2 (read only); address 12h**

Bit	Name	Comment
15-8	-	-
7	TSD	Overtemperature detected: all the drivers are switched off
6	TSD warning	Overtemperature warning level detected, information only
5	-	
4	-	
3	V <sub>S</sub> UV	V <sub>S</sub> undervoltage
2	V <sub>S</sub> OV	V <sub>S</sub> overvoltage
1	V <sub>SB</sub> UV	V <sub>SB</sub> undervoltage
0	V <sub>SA</sub> UV	V <sub>SA</sub> undervoltage

## 8 Application examples

Figure 10. Driving 3 DC-motors simultaneously

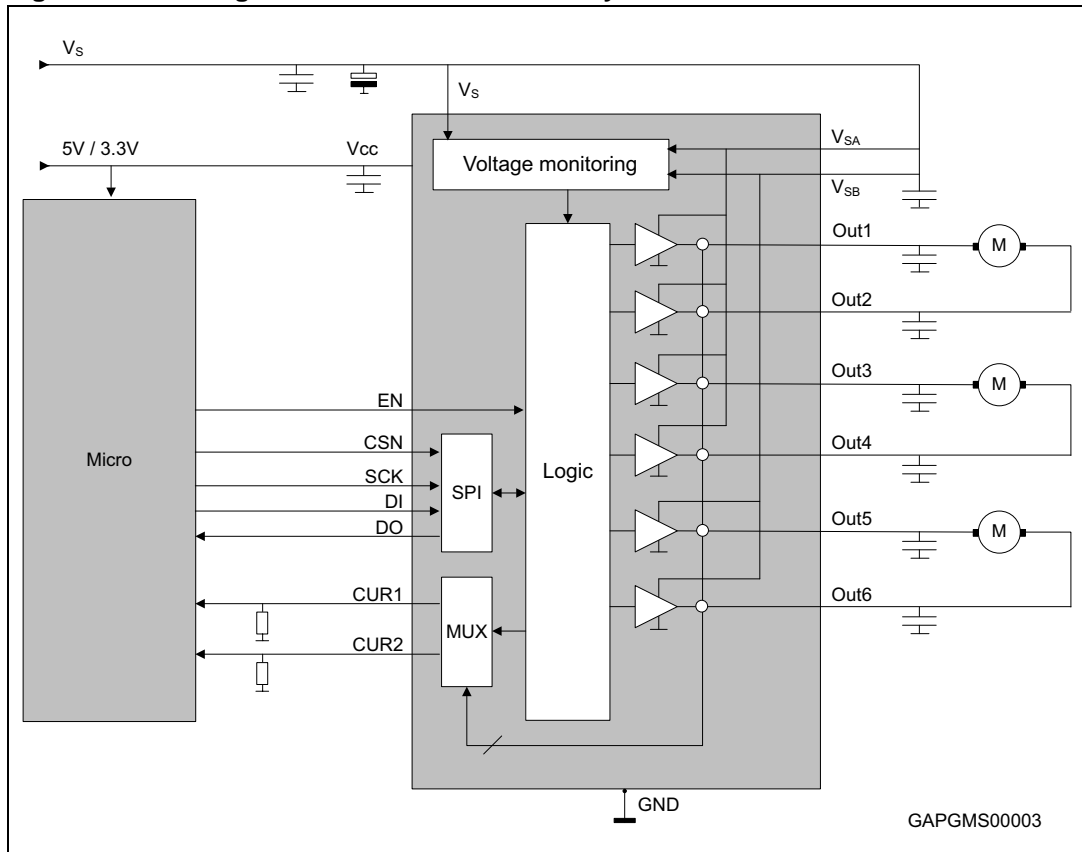
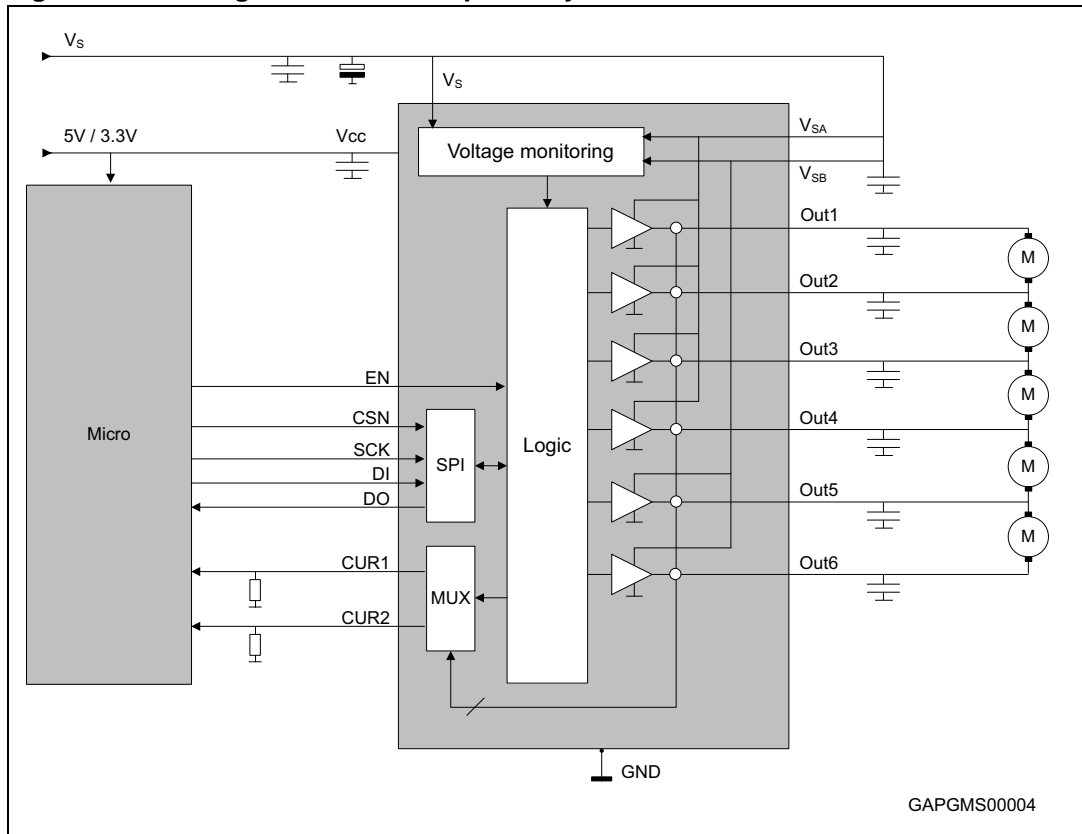

Figure 11. Driving 5 DC-motors sequentially



## 9 Package and PCB thermal data

### 9.1 PowerSSO-36 thermal data

Figure 12. PowerSSO-36 PC board

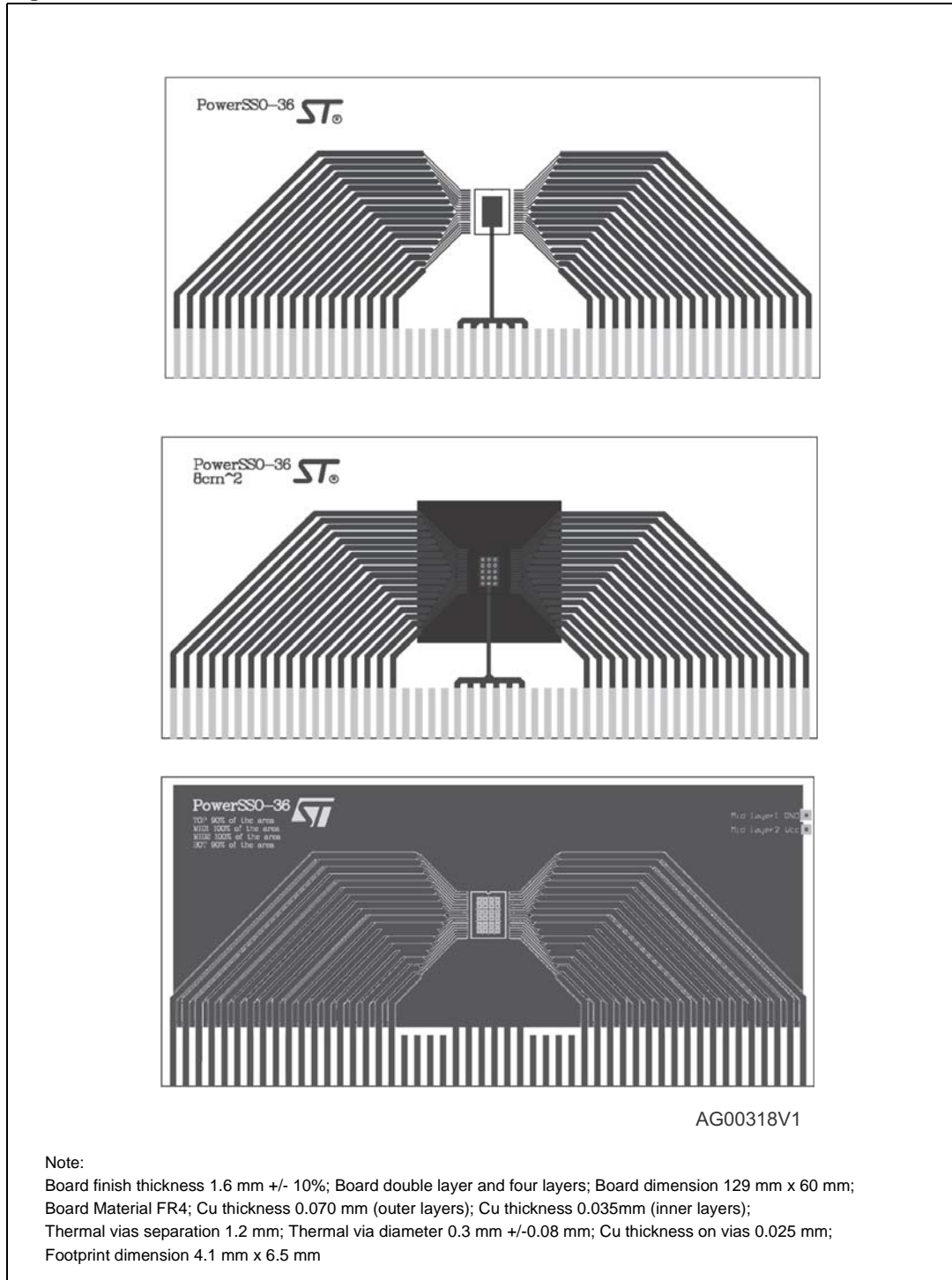
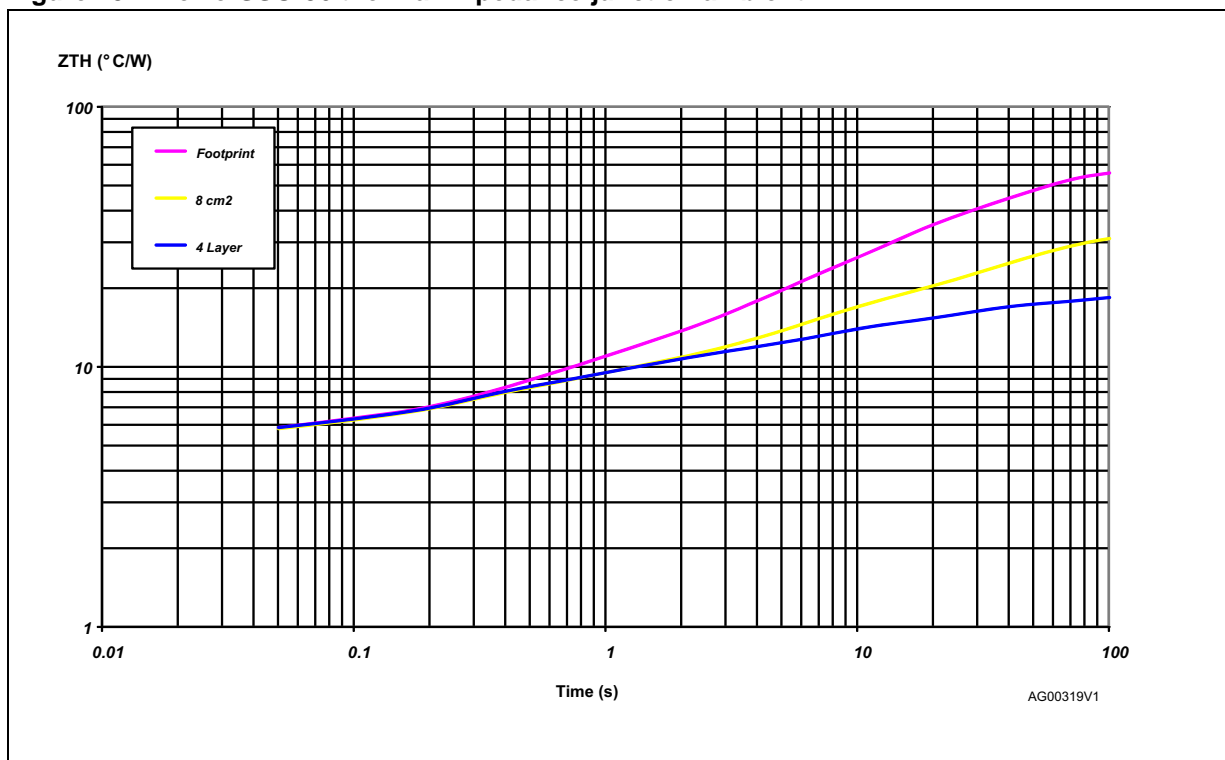

Figure 13. PowerSSO-36 thermal impedance junction ambient





# 10 Package information

## 10.1 ECOPACK<sup>®</sup> package

In order to meet environmental requirements, ST offers these devices in different grades of ECOPACK<sup>®</sup> packages, depending on their level of environmental compliance. ECOPACK<sup>®</sup> specifications, grade definitions and product status are available at: [www.st.com](http://www.st.com). ECOPACK<sup>®</sup> is an ST trademark.

## 10.2 PowerSSO-36<sup>™</sup> mechanical data

Figure 14. PowerSSO-36<sup>™</sup> package dimensions

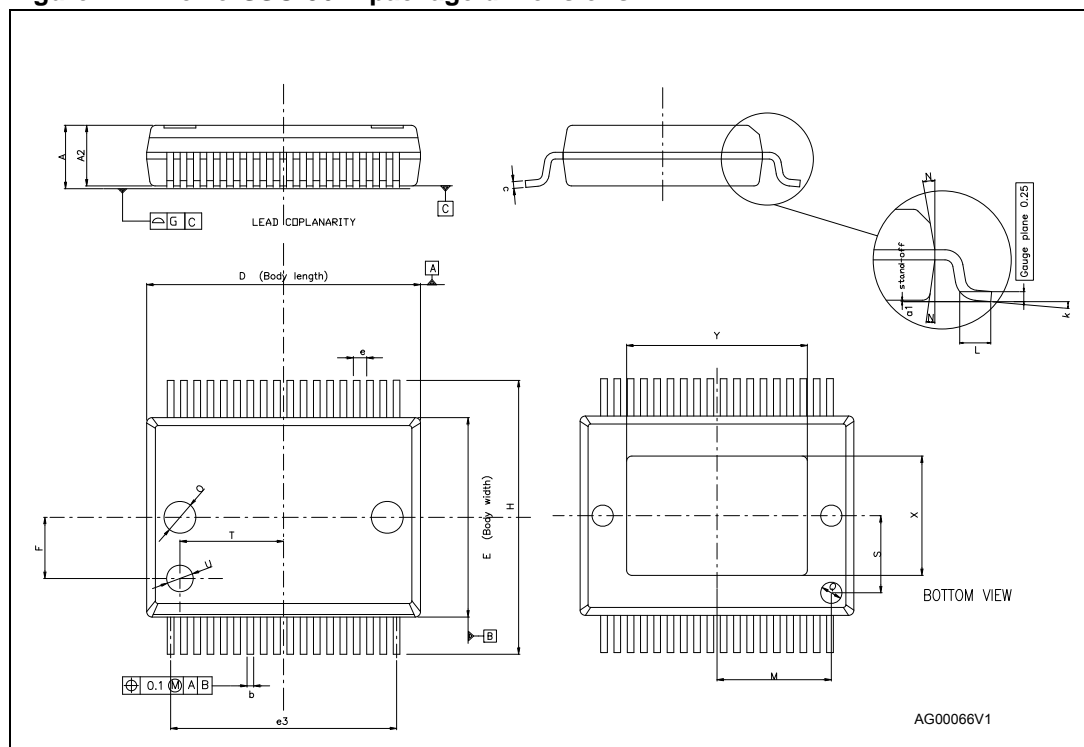

Table 35. PowerSSO-36 mechanical data

Symbol	Millimeters		
	Min.	Typ.	Max.
A	2.15	-	2.45
A2	2.15	-	2.35
a1	0	-	0.1
b	0.18	-	0.36
c	0.23	-	0.32
D <sup>(1)</sup>	10.10	-	10.50
E	7.4	-	7.6
e	-	0.5	-
e3	-	8.5	-
F	-	2.3	-
G	-	-	0.1
G1	-	-	0.06
H	10.1	-	10.5
h	-	-	0.4
k	0°	-	8°
L	0.55	-	0.85
M	-	4.3	-
N	-	-	10°
O	-	1.2	-
Q	-	0.8	-
S	-	2.9	-
T	-	3.65	-
U	-	1	-
X	4.3	-	5.2
Y	6.9	-	7.5

1. "D" and "E" do not include mold flash or protrusions. Mold flash or protrusions shall not exceed 0.15 mm per side (0.006").

### 10.3 Packing information

Figure 15. PowerSSO-36 tube shipment (no suffix)

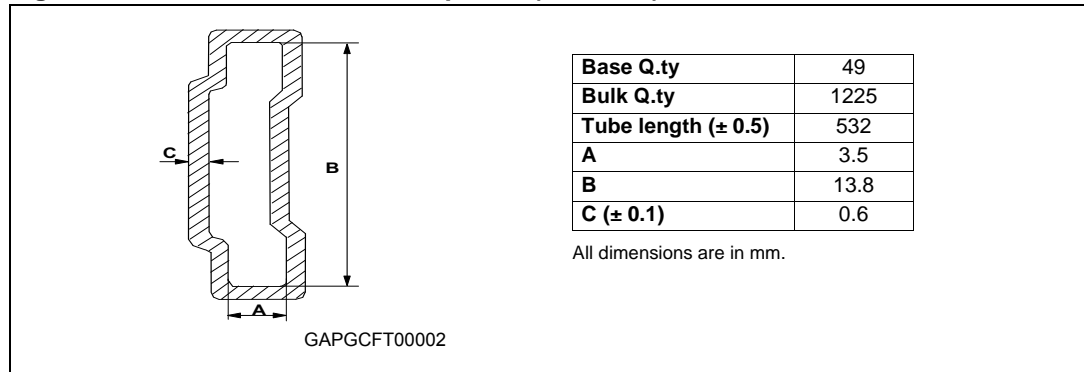
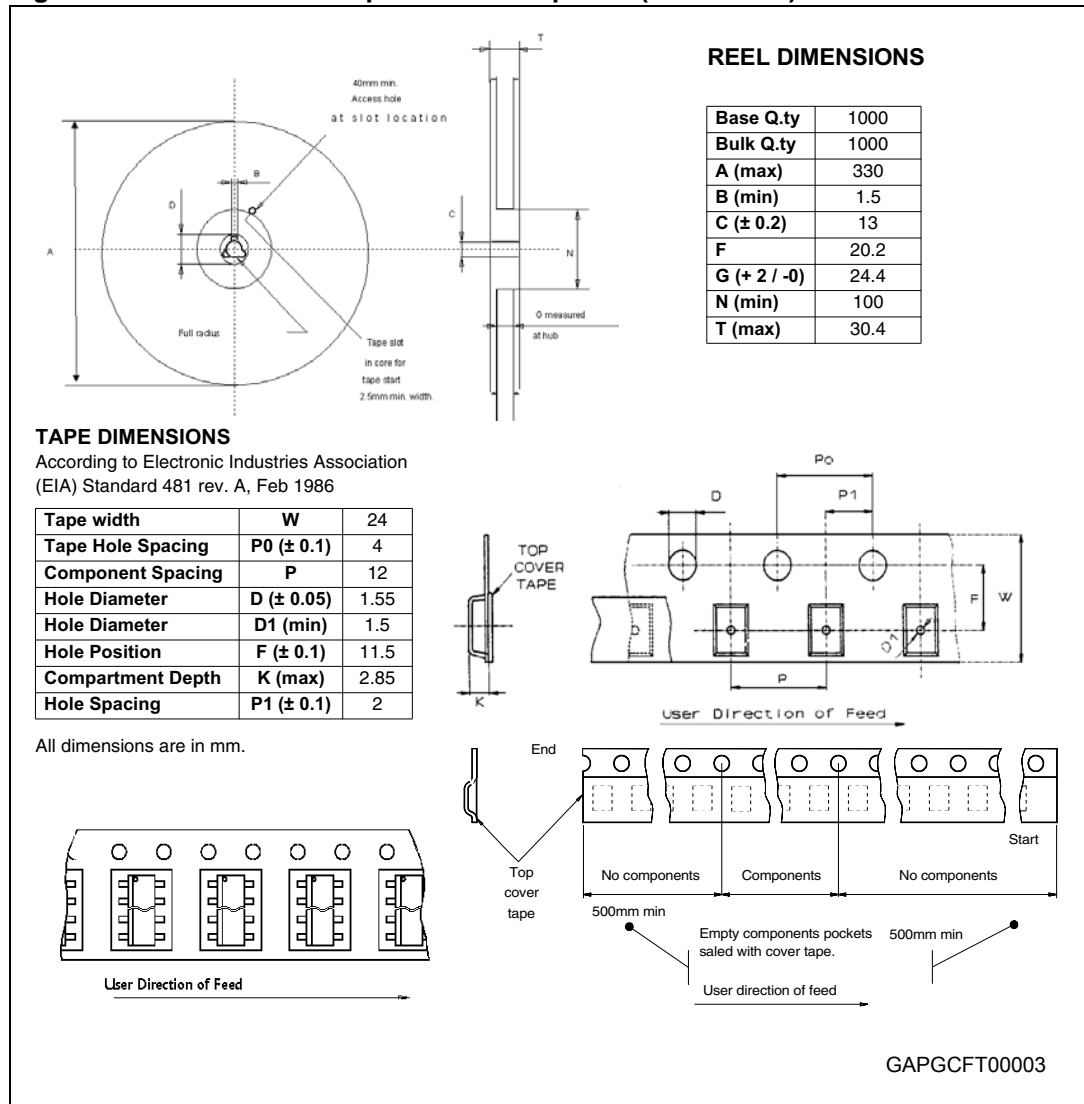

Figure 16. PowerSSO-36 tape and reel shipment (suffix “TR”)



# 11 Revision history

**Table 36. Document revision history**

Date	Revision	Changes
30-Jul-2009	1	Initial release.
21-Jun-2010	2	<p>Updated <a href="#">Features</a> list.            Removed Block diagram on page 1.            Updated <a href="#">Figure 1: Detailed block diagram</a>.            Updated <a href="#">Section 2.3: Standby mode</a>.  <a href="#">Chapter 3: Pin definitions and functions</a>:            – Updated <a href="#">Table 3: Pin description</a>            – Updated <a href="#">Figure 3: Pin connection (top view-not in scale)</a>            Updated <a href="#">Table 16: Dynamic characteristics</a> and <a href="#">Table 24: Control status register</a>.            Inserted <a href="#">Table 30: Control register 5 (read/write); address 05h</a>            Added <a href="#">Chapter 10: Package information</a>.</p>
25-Jan-2011	3	<p>Updated <a href="#">Figure 2: Power on reset</a>            Updated <a href="#">Features</a> list.  <a href="#">Table 9: Over and undervoltage detection</a>            – <math>V_{SUV\ OFF}</math>, <math>V_{SUV\ ON}</math>, <math>V_{SAUV\ ON}</math>, <math>V_{SBUV\ OFF}</math>, <math>V_{SBUV\ ON}</math>: updated maximum value            – <math>V_{SUV\ hyst}</math>, <math>V_{SAUV\ hyst}</math>, <math>V_{SBUV\ hyst}</math>, <math>V_{SOV\ hyst}</math>: added minimum value            – <math>V_{SAUV\ OFF}</math>: updated minimum and maximum values  <a href="#">Table 10: Switches</a>            – Updated following parameters: <math>r_{ONLSLC\ 1-6}</math>, <math>t_{D\ LH}/t_{D\ LH}</math>, <math>I_{QLH}</math>, <math>I_{QLL}</math>, <math>I_{OLDHS1-6}</math>, <math>I_{OLDLSHC1-6}</math>, <math>I_{OLDLSLC1-6}</math>  <a href="#">Table 11: Current monitor output</a>            – Updated <math>I_{CURR1/2\ acc}</math> parameter            Added <a href="#">Table 12: Current monitor dynamic characteristics</a>            Updated following tables:            – <a href="#">Table 25: Control register 1 (read/write); address 01h</a>            – <a href="#">Table 26: Control register 3 (read/write); address 03h</a>            – <a href="#">Table 27: Control register 4 (read/write); address 04h</a>            – <a href="#">Table 30: Control register 5 (read/write); address 05h</a>            – <a href="#">Table 31: Control register 6 (read/write); address 06h</a>            – <a href="#">Table 32: Status register 0 (read only); address 10h</a>            – <a href="#">Table 33: Status register 1 (read only); address 11h</a>            Added <a href="#">Chapter 9: Package and PCB thermal data</a></p>

Table 36. Document revision history (continued)

Date	Revision	Changes
23-Feb-2011	4	Updated <i>Features</i> list. Updated <i>Section 2.2: Power supply: <math>V_{SA}</math>, <math>V_{SB}</math></i> Updated following tables: – <i>Table 3: Pin description</i> – <i>Table 11: Current monitor output</i> – <i>Table 12: Current monitor dynamic characteristics</i> – <i>Table 16: Dynamic characteristics</i> – <i>Table 20: Global status byte</i>
19-Sep-2013	5	Updated disclaimer.

**Please Read Carefully:**

Information in this document is provided solely in connection with ST products. STMicroelectronics NV and its subsidiaries ("ST") reserve the right to make changes, corrections, modifications or improvements, to this document, and the products and services described herein at any time, without notice.

All ST products are sold pursuant to ST's terms and conditions of sale.

Purchasers are solely responsible for the choice, selection and use of the ST products and services described herein, and ST assumes no liability whatsoever relating to the choice, selection or use of the ST products and services described herein.

No license, express or implied, by estoppel or otherwise, to any intellectual property rights is granted under this document. If any part of this document refers to any third party products or services it shall not be deemed a license grant by ST for the use of such third party products or services, or any intellectual property contained therein or considered as a warranty covering the use in any manner whatsoever of such third party products or services or any intellectual property contained therein.

**UNLESS OTHERWISE SET FORTH IN ST'S TERMS AND CONDITIONS OF SALE ST DISCLAIMS ANY EXPRESS OR IMPLIED WARRANTY WITH RESPECT TO THE USE AND/OR SALE OF ST PRODUCTS INCLUDING WITHOUT LIMITATION IMPLIED WARRANTIES OF MERCHANTABILITY, FITNESS FOR A PARTICULAR PURPOSE (AND THEIR EQUIVALENTS UNDER THE LAWS OF ANY JURISDICTION), OR INFRINGEMENT OF ANY PATENT, COPYRIGHT OR OTHER INTELLECTUAL PROPERTY RIGHT.**

**ST PRODUCTS ARE NOT DESIGNED OR AUTHORIZED FOR USE IN: (A) SAFETY CRITICAL APPLICATIONS SUCH AS LIFE SUPPORTING, ACTIVE IMPLANTED DEVICES OR SYSTEMS WITH PRODUCT FUNCTIONAL SAFETY REQUIREMENTS; (B) AERONAUTIC APPLICATIONS; (C) AUTOMOTIVE APPLICATIONS OR ENVIRONMENTS, AND/OR (D) AEROSPACE APPLICATIONS OR ENVIRONMENTS. WHERE ST PRODUCTS ARE NOT DESIGNED FOR SUCH USE, THE PURCHASER SHALL USE PRODUCTS AT PURCHASER'S SOLE RISK, EVEN IF ST HAS BEEN INFORMED IN WRITING OF SUCH USAGE, UNLESS A PRODUCT IS EXPRESSLY DESIGNATED BY ST AS BEING INTENDED FOR "AUTOMOTIVE, AUTOMOTIVE SAFETY OR MEDICAL" INDUSTRY DOMAINS ACCORDING TO ST PRODUCT DESIGN SPECIFICATIONS. PRODUCTS FORMALLY ESCC, QML OR JAN QUALIFIED ARE DEEMED SUITABLE FOR USE IN AEROSPACE BY THE CORRESPONDING GOVERNMENTAL AGENCY.**

Resale of ST products with provisions different from the statements and/or technical features set forth in this document shall immediately void any warranty granted by ST for the ST product or service described herein and shall not create or extend in any manner whatsoever, any liability of ST.

ST and the ST logo are trademarks or registered trademarks of ST in various countries.

Information in this document supersedes and replaces all information previously supplied.

The ST logo is a registered trademark of STMicroelectronics. All other names are the property of their respective owners.

© 2013 STMicroelectronics - All rights reserved

STMicroelectronics group of companies

Australia - Belgium - Brazil - Canada - China - Czech Republic - Finland - France - Germany - Hong Kong - India - Israel - Italy - Japan - Malaysia - Malta - Morocco - Philippines - Singapore - Spain - Sweden - Switzerland - United Kingdom - United States of America

[www.st.com](http://www.st.com)

# Mouser Electronics

Authorized Distributor

Click to View Pricing, Inventory, Delivery & Lifecycle Information:

[STMicroelectronics:](#)

[L99MD02XPTR](#)