

18 Bit RGB, 8/16-bit parallel, SPI interface



*Dimension 68x48x2.2mm (right picture)
and 84x58x4.3mm (incl. PCAP, left one)*

FEATURES

- 2.8" TFT FULL COLOR DISPLAY
- AACS TECHNOLOGY WITH IPS FOR UNLIMITED VIEWING ANGLE
- 240x320x3 DOTS, CONTROLLER ST7789V
- 1000 or 800cd/m² WITHOUT/WITH TOUCHPANEL
- 4 DIFFERENT INTERFACES AVAILABLE:
 - 18-BIT RGB INTERFACE
 - 8-BIT PARALLEL INTERFACE
 - 16-BIT PARALLEL INTERFACE
 - SPI INTERFACE
- INTEGRATED CONTROLLER ST7789V
- SUPPLY VOLTAGE 3.3V
- WIDE TEMPERATURE RANGE (T_{OP} -20°C - +70°C)
- OPTIONALLY WITH PCAP AND CONTROLLER GT911

ORDERING CODES

- 2.8" TFT, 240x320 IPS, 1000cd/m²
- AS ABOVE BUT WITH OPTICALLY BONDED PCAP

EA TFT028-23AINN
EA TFT028-23AITC

ACCESSORY

- ZIF CONNECTOR 0.3MM, BOTTOM CONTACT

EA WF030-39S

CONTENT

.....	1
CONTENT	2
REVISION HISTORY	3
GENERAL DESCRIPTION	4
OPTICAL CHARACTERISTICS	5
DEFINITION OF RESPONSE TIME: T_R AND T_F	5
DEFINITION OF CONTRAST RATIO.....	6
VIEWING ANGLE.....	6
DEFINITION OF WHITE UNIFORMITY.....	6
THE DEFINITION OF COLOR GAMUT -COLOR CHROMATICITY CIE 1931.....	7
ELECTRICAL SPECIFICATIONS	8
ABSOLUTE RATINGS OF ENVIRONMENT.....	8
ELECTRICAL ABSOLUTE MAXIMUM RATINGS.....	8
DC ELECTRICAL CHARACTERISTICS OF THE TFT LCD.....	9
BACKLIGHT UNIT	10
APPLICATION EXAMPLE FOR DRIVING THE LED BACKLIGHT.....	10
TIMING SPECIFICATIONS	11
POWER SEQUENCE.....	11
AC TIMING SPI INTERFACE CHARACTERISTICS.....	12
AC TIMING RGB INTERFACE CHARACTERISTICS.....	13
DATA INPUT FORMAT.....	15
PCAP TOUCHPANEL	16
TIMING SPECIFICATIONS FOR CTP.....	16
REGISTER INFORMATION OF MODULE.....	19
FUNCTION MODE.....	27
RELIABILITY CONDITION	29
QUALITY UNITS	30
INSPECTION METHOD.....	30
QUALITY LEVEL.....	30
DEFINITION.....	30
DEFINITION OF DOT DEFECT.....	31
VISUAL INSPECTION.....	32
PIN DEFINITION	37
INTERFACE MODE SELECTION.....	38
INITIALIZATION EXAMPLE	39
ACCESSORY EA WF030-39S	41
DIMENSIONS	42

REVISION HISTORY

Date	Rev.	Page(s)	Description
2019-03-04	1.0	All	First issue
2019-03-07		10	Adding an Application Example
2019-05-23	2.0	42, 43	FPC pin count changed, flip FPC to back side
2019-10-11		41	Adding Initialization Example
2021-06-17		42	Adding C/Dwg for EA TFT028-23AINN

GENERAL DESCRIPTION

With its new 2.8" TFT displays ELECTRONIC ASSEMBLY launches the worldwide first small-sized displays with high-quality. With its IPS technology these displays provide full viewing angle with all-angle color stability management (AACS). This means that color stays same even when viewing angle is changing. So it can be used in portrait mode 240x320 or landscape mode 320x240 direction without any disadvantage. Display brightness is enormous with typ. 1000cd/m² and paves the way for manifold applications in industrially and medically field, even for usage at direct sunlight.

The displays provide many interface modes like standard RGB interface which is suitable even for fast changing display content. The 4-wire SPI interface is perfect for pin saving applications and the 16-bit and 8-bit μ C data bus interface enables parallel access to the display.

The version EA TFT028-23AITC comes with an optical bonded (OCA) PCAP touch panel. Interface is I²C which makes it easy to read out directly the coordinates.

The single connector for display interface, power supply for backlight and touch panel interface saves time in production. It also saves space on pcb because there's 1 single ZIFF connector necessary only. For SMD mount we do provide a connector EA WF030-39S as an accessory.

Item	Specification	Unit
Screen Size	2.8 inches	Diagonal
Display Resolution	240 (H)(RGB) x 320 (V)	Pixel
Active Area (LCD)	43.2(H) x 57.6(V)	mm
Outline Dimension	48.0 (H) x 68.37(V) x 2.15 (T)	mm
With Touchpanel	58.0 (H) x 84.0(V) x 4.325MAX (T)	mm
Display Mode	Normally Black mode / IPS (AACS)	--
Pixel Arrangement	R,G,B Vertical Stripe	--
Display Color	262K	--
Viewing Direction	Free	--
Input Interface	SPI or 8-Bit or 16 Bit or RGB	--

Table 1

OPTICAL CHARACTERISTICS

Test equipment setup: after stabilizing and leaving the panel alone shall be warmed up for the stable operation of LCM, the measurement should be executed. Measurement should be executed in a stable, windless, and dark room. Optical specifications are measured by Topcon BM-7(fast) with a viewing angle of 2° at a distance of 50cm and normal direction.

Table 2

Item	Symbol	Condition	Min	Type	Max	Unit	Note	
Brightness (Module)	B		900	1000	--	cd/m ²	incl. PCAP	
Response time	Tr +Tf	$\theta=0^\circ$	-	30	40	ms	.	
Contrast ratio	CR	Normal viewing angle	600	800	--	--		
Luminance Uniformity	ΔL		70			%		
Color Chromaticity (CIE 1931)	White	Wx	$\theta=0^\circ$ Normal Viewing Angle	0.286	0.306	0.326	--	BM-7A
		Wy		0.307	0.327	0.347		
Viewing Angle (6H)	Hor.	θR	CR \geq 10	60	80	--	Degree	
		θL		60	80	--		
	Ver.	θU		60	80	--		
		θD		60	80	--		

DEFINITION OF RESPONSE TIME: T_r AND T_f

The response time is defined as the following figure and shall be measured by switching the input signal for "black" and "white".

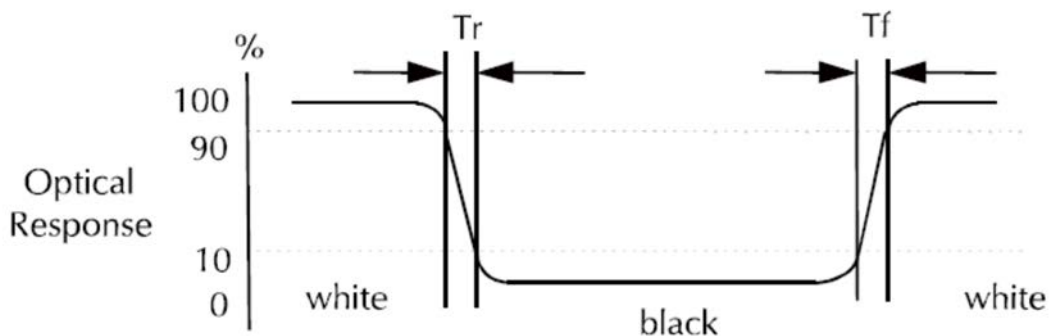

DEFINITION OF CONTRAST RATIO

$$\text{Contrast Ratio (CR)} = \frac{\text{Brightness measured when LCD is at "white state"}}{\text{Brightness measured when LCD is at "black state"}}$$

Measured at the center area of the panel when all the input terminals of LCD panel are electrically opened.

VIEWING ANGLE

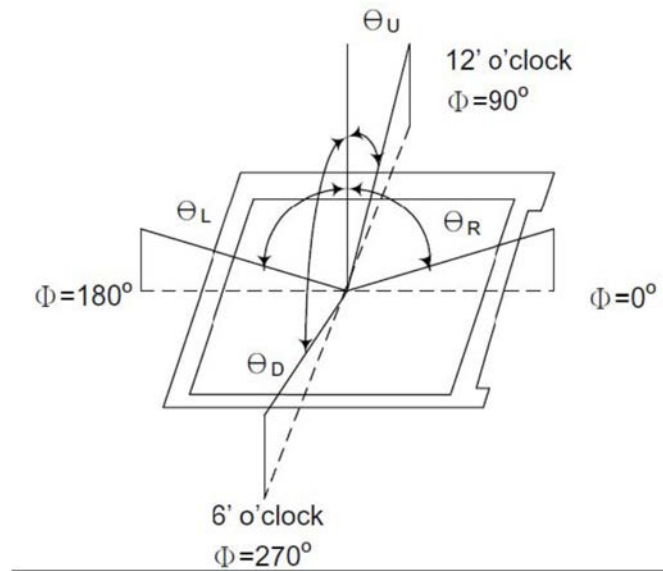

DEFINITION OF WHITE UNIFORMITY

$$\text{White Uniformity} = \frac{\text{Min. luminance of white among 9-points}}{\text{Max. luminance of white among 9-points}} \times 100\%$$

THE DEFINITION OF COLOR GAMUT -COLOR CHROMATICITY CIE 1931

Color coordinate of white & red, green, blue at center point.

Color Gamut: NTSC (%) = (RGB Triangle Area / NTSC Triangle Area) x 100

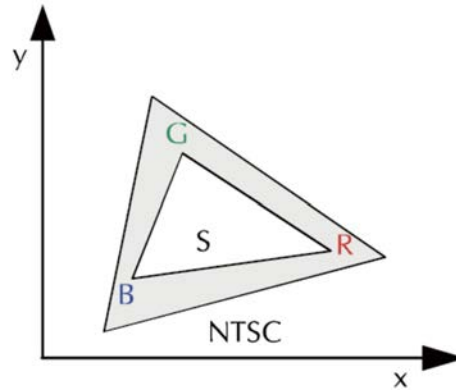

ELECTRICAL SPECIFICATIONS

ABSOLUTE RATINGS OF ENVIRONMENT

If the operating condition exceeds the following absolute maximum ratings, the TFT module may be damaged permanently.

Table 3

Item	Symbol	Min.	Max.	Unit	Note
Storage temperature	TSTG	-30	80	°C	(1)
Operating temperature	TOPR	-20	70	°C	(1)

Note (1) Only operation is guaranteed at operating temperature. Contrast, response time, another display quality are evaluated at +25°C.

ELECTRICAL ABSOLUTE MAXIMUM RATINGS

Table 4

Item	Symbol	Rating	Unit
Supply Voltage	VDD	- 0.3 ~ +4.6	V
Supply Voltage (Logic)	VDDI	- 0.3 ~ +4.6	V
Driver Supply Voltage	VGH-VGL	-0.3 ~ +30.0	V
Logic Input Voltage Range	VIN	-0.3 ~ VDDI + 0.5	V
Logic Output Voltage Range	VO	-0.3 ~ VDDI + 0.5	V

Note: If one of the above items is exceeded its maximum limitation momentarily, the quality of the product may be degraded. Absolute maximum limitation, therefore, specify the values exceeding which the product may be physically damaged. Be sure to use the product within the specified range only.

DC ELECTRICAL CHARACTERISTICS OF THE TFT LCD

Table 5

Parameter	Symbol	Condition	Specification			Unit	Related Pins
			MIN.	TYP.	MAX.		
Power & Operation Voltage							
System Voltage	VDD	Operating voltage	2.4	2.75	3.3	V	
Interface Operation Voltage	VDDI	I/O Supply Voltage	1.65	1.8	3.3	V	
Gate Driver High Voltage	VGH		12.2		14.97	V	Note 4
Gate Driver Low Voltage	VGL		-12.5		-7.16	V	
Gate Driver Supply Voltage		VGH-VGL	19.36		27.47	V	Note 5
Input / Output							
Logic-High Input Voltage	VIH		0.7VDDI		VDDI	V	Note 1
Logic-Low Input Voltage	VIL		VSS		0.3VDDI	V	Note 1
Logic-High Output Voltage	VOH	IOH = -1.0mA	0.8VDDI		VDDI	V	Note 1
Logic-Low Output Voltage	VOL	IOL = +1.0mA	VSS		0.2VDDI	V	Note 1
Logic-High Input Current	IIH	VIN = VDDI			1	uA	Note 1
Logic-Low Input Current	IIL	VIN = VSS	-1			uA	Note 1
Input Leakage Current	IIL	IOH = -1.0mA	-0.1		+0.1	uA	Note 1
VCOM Voltage							
VCOM amplitude	VCOM			VSS		V	
Source Driver							
Source Output Range	Vsout		VAN		VAP	V	
Gamma Reference Voltage(Positive)	VAP		4.45		6.4	V	Note 6
Gamma Reference Voltage(Negative)	VAN		-4.6		-2.65	V	
Source Output Settling Time	Tr	Below with 99% precision			20	us	Note 2
Output Offset Voltage	VOFFSET				35	mV	Note 3

Notes:

1. TA= -30 to 70 °C (to +85 no damage).
2. Source channel loading= 2KΩ+12pF/channel, Gate channel loading=5KΩ+40pF/channel.
3. The Max value is between measured point of source output and gamma setting value.
4. When evaluating the maximum and minimum of VGH, VDD=2.8V
5. The maximum value of |VGH-VGL| cannot over 30V.
6. Default register setting of Vcom and Vcom offset is 20h

BACKLIGHT UNIT

The backlight system is an edge-lighting type with 9 white LED (Light Emitting Diode). The characteristics of 9 white LEDs are shown in the following tables.

Table 6

Characteristics	Symbol	Min.	Typ.	Max.	Unit	Note
Forward Voltage	V_f	25.2	27.0	28.8	V	
Forward Current	I_f	-	-	20	mA	(1)
Power Consumption	$P_{b/l}$	-	540	-	mW	(2)
LED Life time	-	20000	-		hr	(3)(4)

Note (1) 9 LEDs connected in series

(2) Where $I_f = 20\text{mA}$, $V_f = 27.0\text{V}$, $P_{b/l} = V_f \times I_f$

(3) The environmental conducted under ambient air flow, at $T_a = 25 \pm 2^\circ\text{C}$, 60% RH $\pm 5\%$

(4) Higher temperatures decreasing LED life time; in this case reduce LED current to help life time

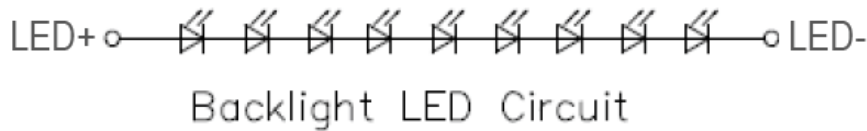

APPLICATION EXAMPLE FOR DRIVING THE LED BACKLIGHT

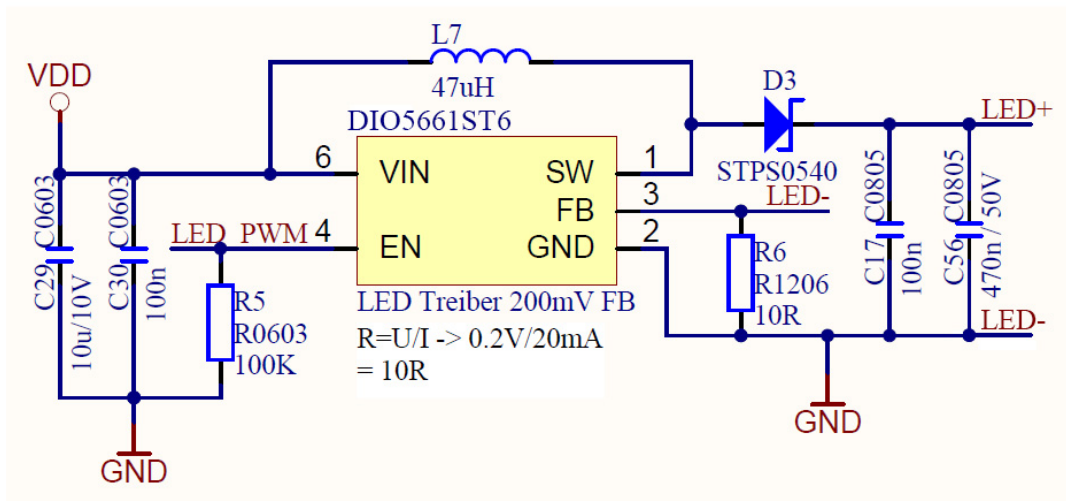

TIMING SPECIFICATIONS

POWER SEQUENCE

Power on & Power off:

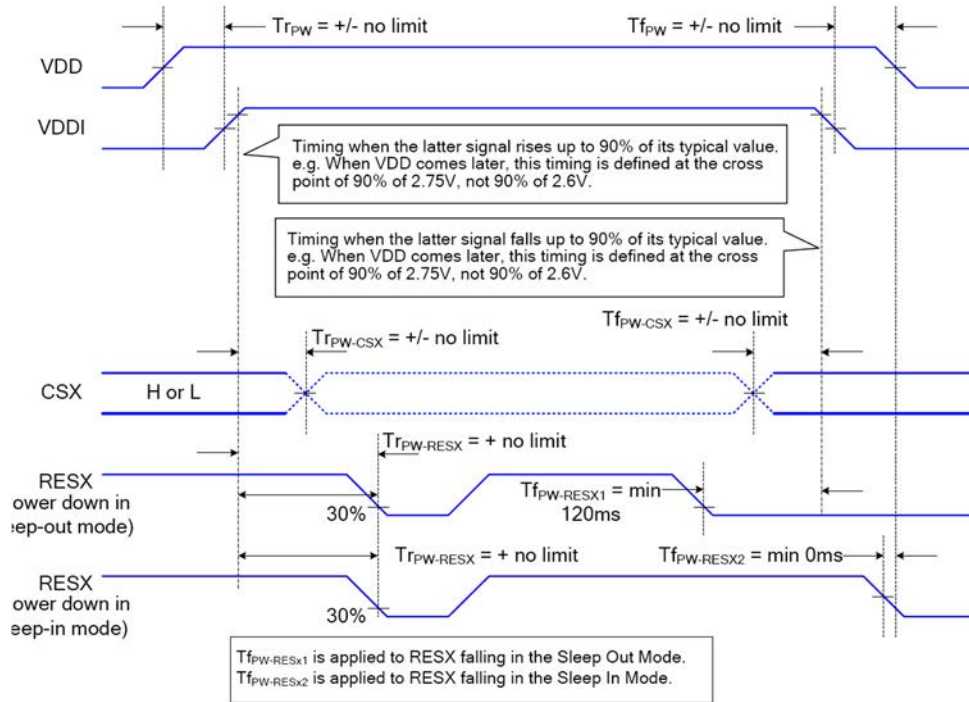

Fig.1 Power ON/OFF Sequence

Note: VCI = IOVCC

Voltage Generation

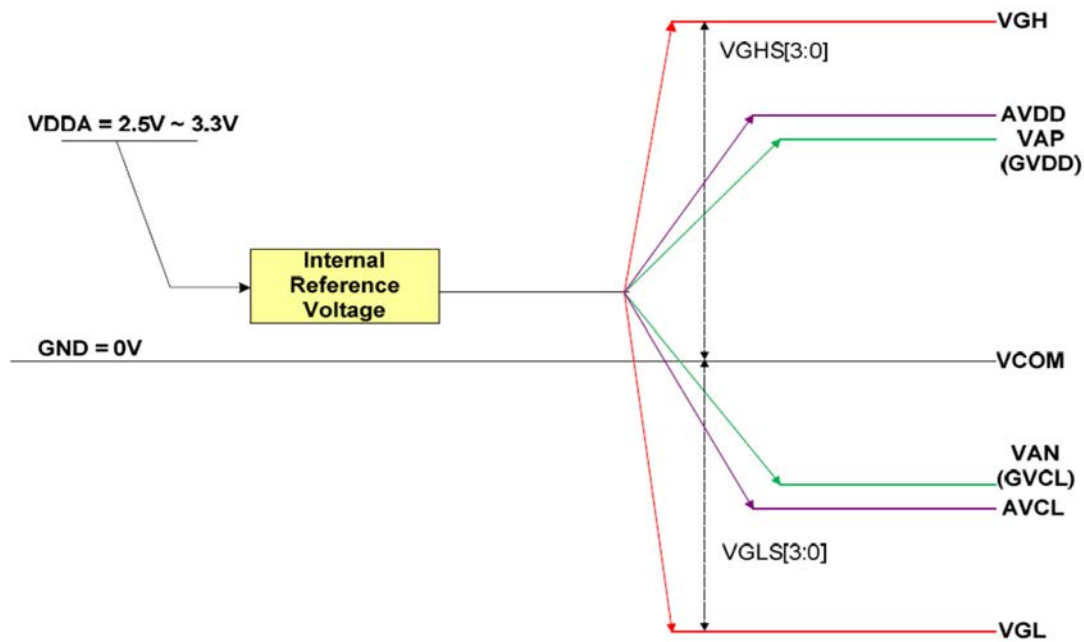

Fig.2 Voltage Generation

AC TIMING SPI INTERFACE CHARACTERISTICS

At Ta = -20 °C To +70 °C, VCI =2.8±0.1V, GND = 0V.

Refer below, the bus-timing diagram for AC Characteristics In 4-SPI interface.

Table 7

Signal	Symbol	Parameter	MIN	MAX	Unit	Description
CSX	T _{CSS}	Chip select setup time (write)	15		ns	
	T _{CSH}	Chip select hold time (write)	15		ns	
	T _{CSS}	Chip select setup time (read)	60		ns	
	T _{SCC}	Chip select hold time (read)	65		ns	
	T _{CHW}	Chip select "H" pulse width	40		ns	
SCL	T _{SCYCW}	Serial clock cycle (Write)	66		ns	-write command & data ram
	T _{SHW}	SCL "H" pulse width (Write)	15		ns	
	T _{SLW}	SCL "L" pulse width (Write)	15		ns	
	T _{SCYCR}	Serial clock cycle (Read)	150		ns	-read command & data ram
	T _{SHR}	SCL "H" pulse width (Read)	60		ns	
	T _{SLR}	SCL "L" pulse width (Read)	60		ns	
D/CX	T _{DCS}	D/CX setup time	10		ns	
	T _{DCH}	D/CX hold time	10		ns	
SDA (DIN)	T _{SDS}	Data setup time	10		ns	
	T _{SDH}	Data hold time	10		ns	
DOUT	T _{ACC}	Access time	10	50	ns	For maximum CL=30pF
	T _{OH}	Output disable time	15	50	ns	For minimum CL=8pF

Note : The rising time and falling time (Tr, Tf) of input signal are specified at 15 ns or less. Logic high and low levels are specified as 30% and 70% of VDDI for Input signals.

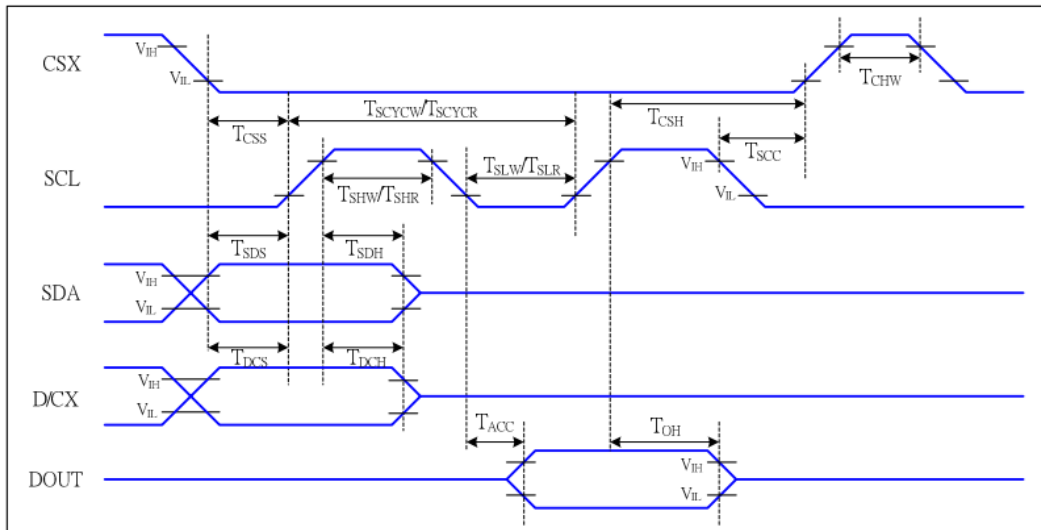

Fig.3-SPI Interface Characteristics

AC TIMING RGB INTERFACE CHARACTERISTICS

At Ta = -20 °C To +70 °C, VCI =3.15±0.1V, GND = 0V.

Table 8

Signal	Symbol	Parameter	MIN	MAX	Unit	Description
HSYNC, VSYNC	T_{SYNCS}	VSYNC, HSYNC Setup Time	15	-	ns	
ENABLE	T_{ENS}	Enable Setup Time	15	-	ns	
	T_{ENH}	Enable Hold Time	15	-	ns	
DOTCLK	PWDH	DOTCLK High-level Pulse Width	30	-	ns	
	PWDL	DOTCLK Low-level Pulse Width	30	-	ns	
	T_{CYCD}	DOTCLK Cycle Time	66	-	ns	
	Trghr, Trghf	DOTCLK Rise/Fall time	-	15	ns	
DB	T_{PDS}	PD Data Setup Time	15	-	ns	
	T_{PDH}	PD Data Hold Time	15	-	ns	

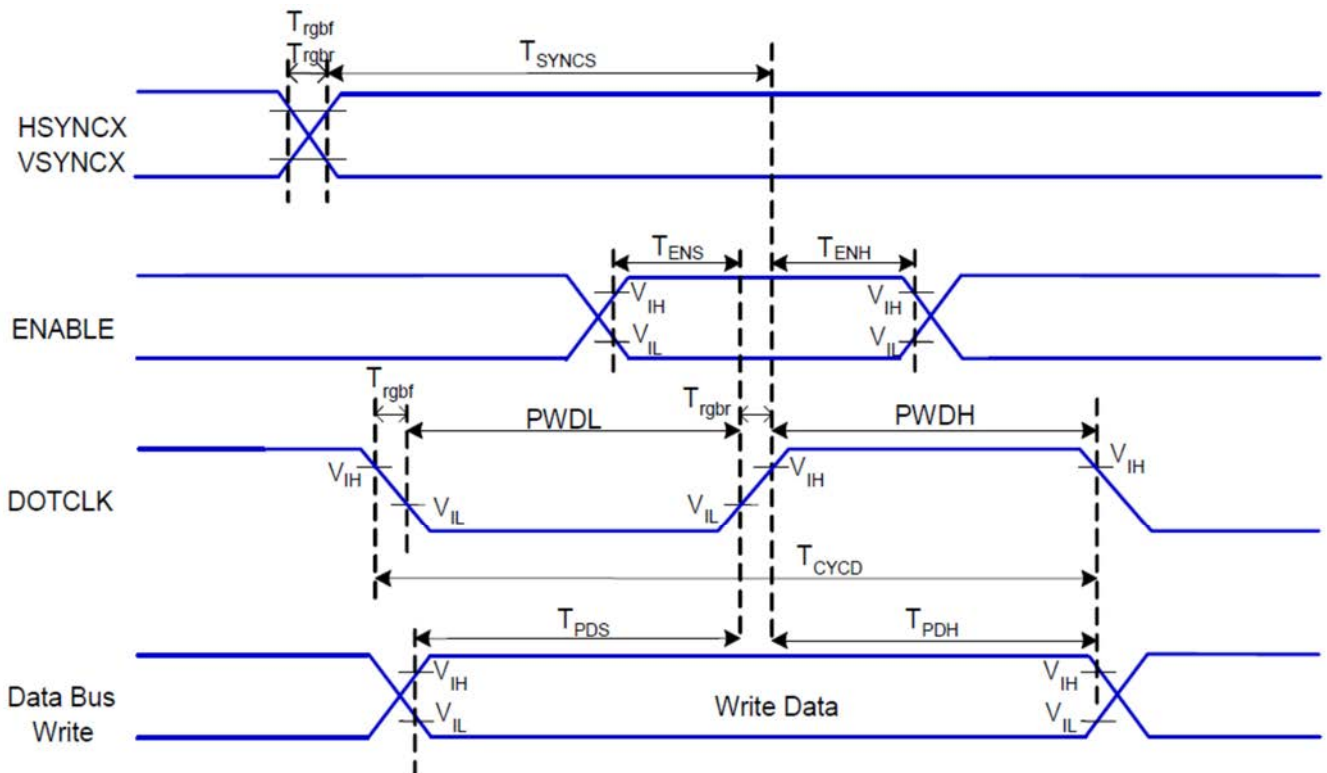
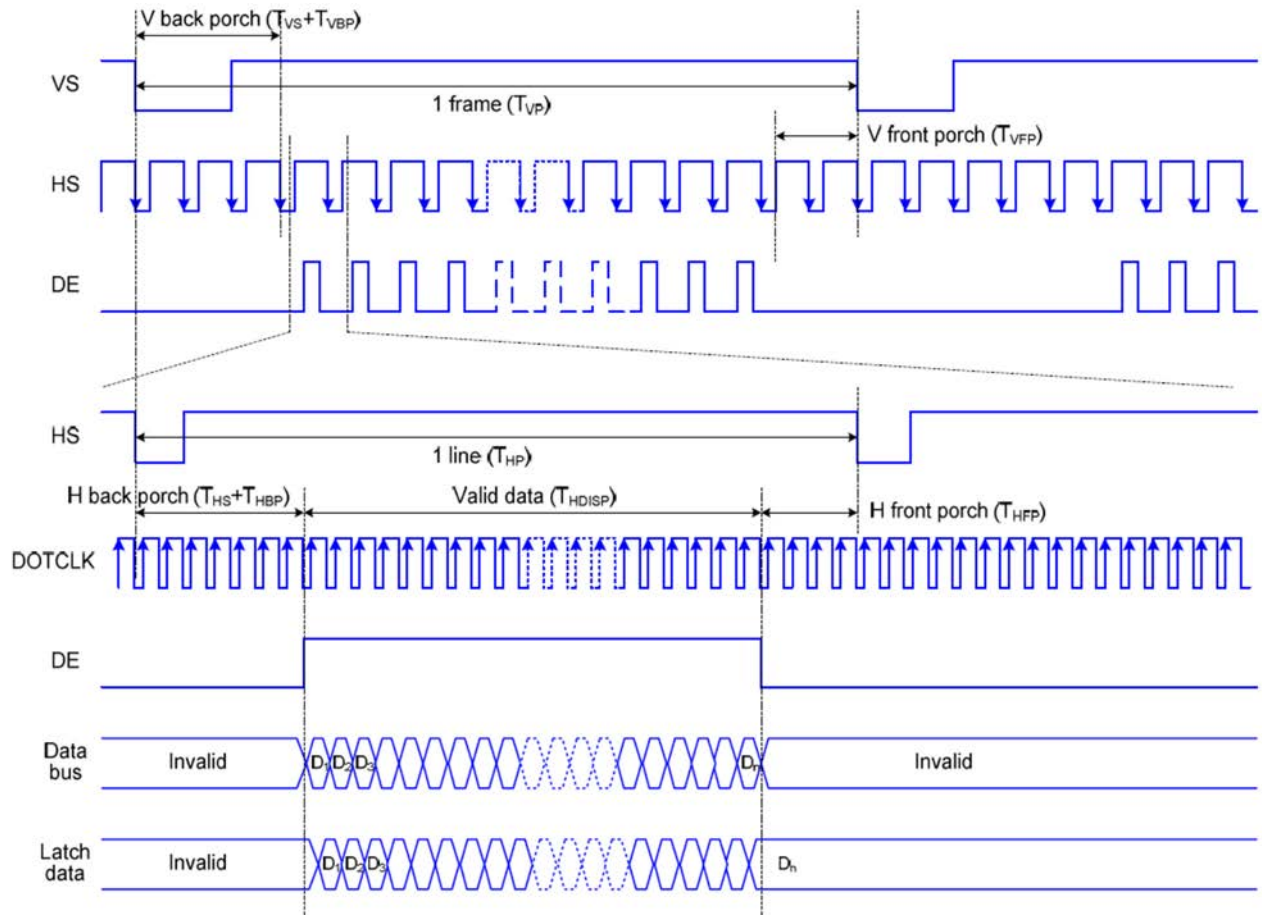

Fig.4 RGB Interface Timing Characteristics



Note: The setting of front porch and back porch in host must match that in IC as this mode.

DATA INPUT FORMAT

Write data for 18-bit/pixel (RGB 6-6-6-bit input), 262K-Colors

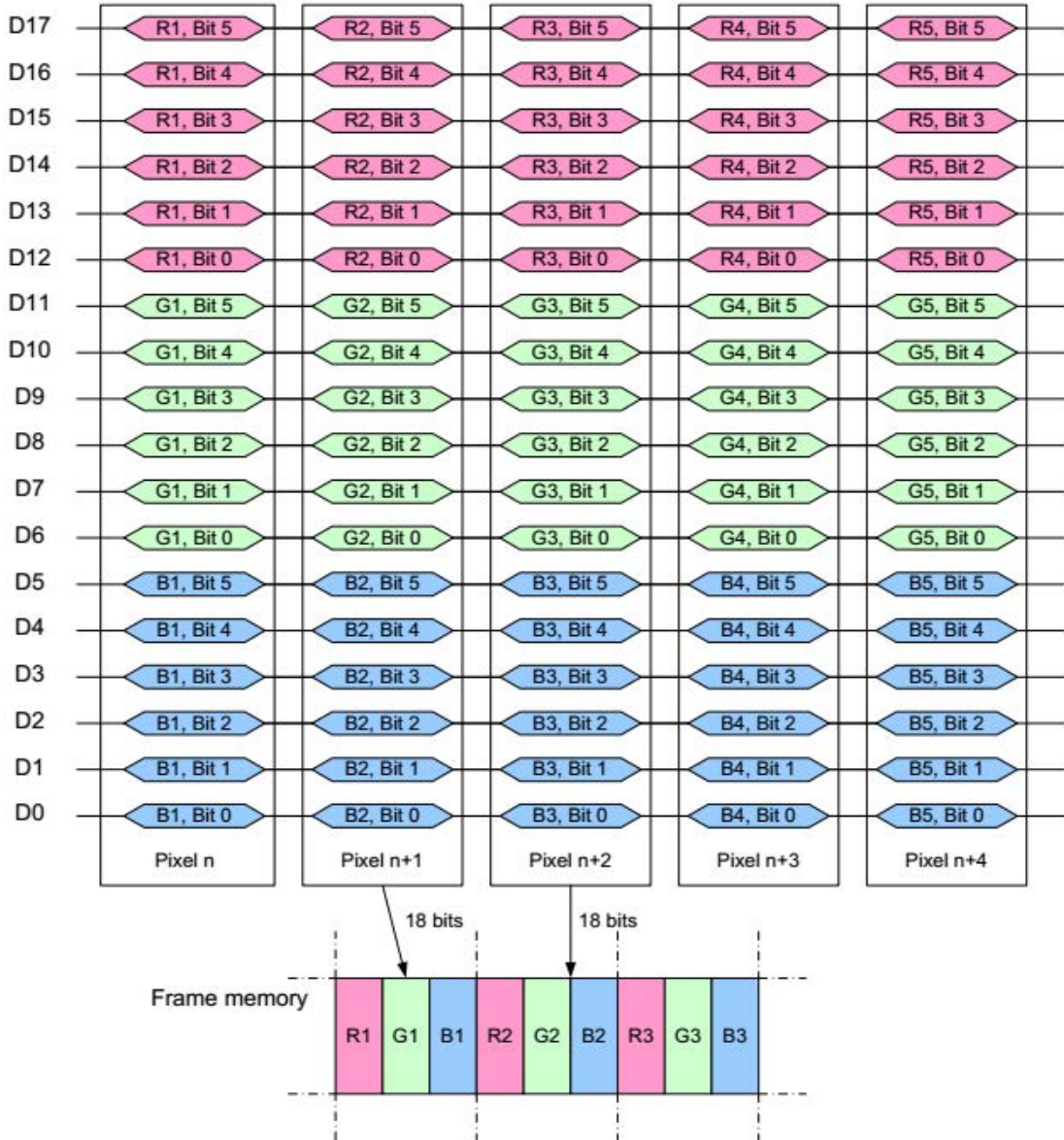

Fig.5 Data input format

PCAP TOUCHPANEL

Table 9

Item	Specification	Unit
Touch panel Size	2.8 inches	
Active Area (Sensor)	45.4 (H) x 59.8 (V)	mm
Input type	5 Point multi touch	
Controller	GT911	
Interface mode	I ² C	
Normal mode operating current	typ. 8	mA

TIMING SPECIFICATIONS FOR CTP

I²C Communication

This module provides standard I²C interface for communication. In the system, this module always works in slave mode, all communications are initiated by master, and the baud rate can be up to 400K bps. The definition of I²C timing is as following:

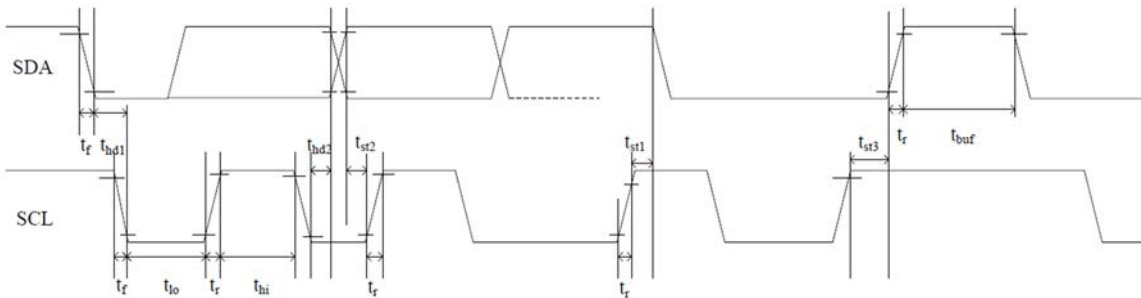

Fig.6 RGB Interface Timing Characteristics

Test condition: 3.3V communication interface, 400Kbps, pull up resistor is 2K ohm

Parameter	Symbol	MIN.	Max.	Unit
SCL low period	t_{lo}	0.9	-	US
SCL high period	t_{hi}	0.8	-	US
SCL setup time for START condition	t_{st1}	0.4	-	US
SCL setup time for STOP condition	t_{st3}	0.4	-	US
SCL hold time for START condition	t_{hd1}	0.3	-	US
SDA setup time	t_{st2}	0.4	-	US
SDA hold time	t_{hd2}	0.4	-	US

This module has 2 sets of slave address 0xBA/0xBB & 0x28/29. Master can control Reset & INT pin to configure the slave address in power on initial state like following:

Power on diagram:

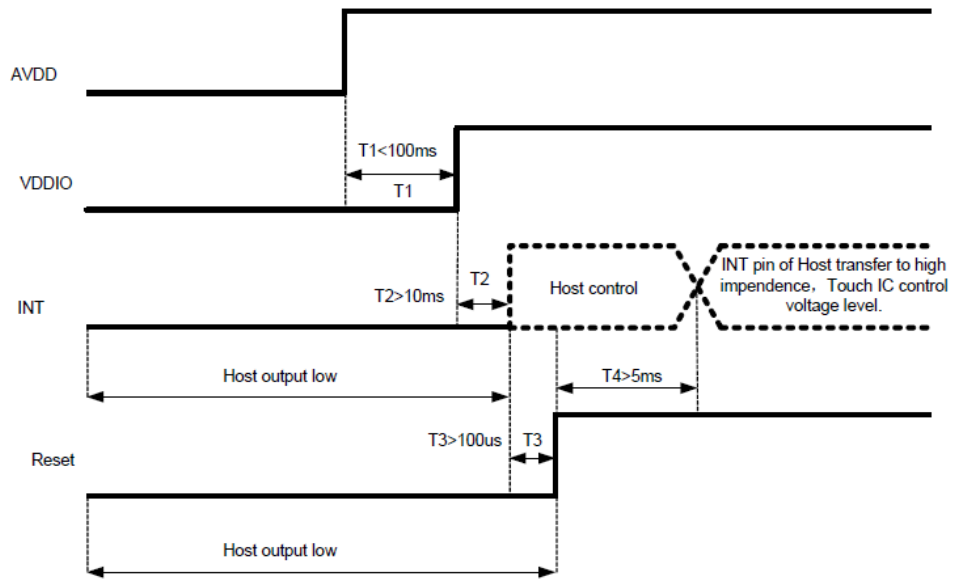

Fig.7 Power on diagram

Timing of setting slave address to 0x28/0x29:

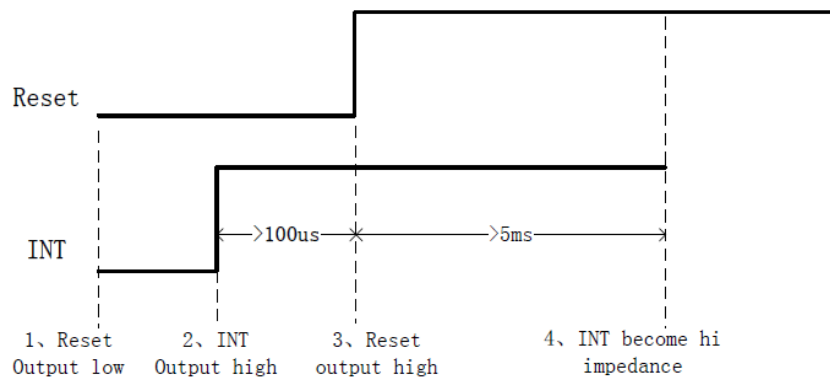

Fig.8(a) Timing of setting slave address

Timing of setting slave address to 0xBA/0xBB:

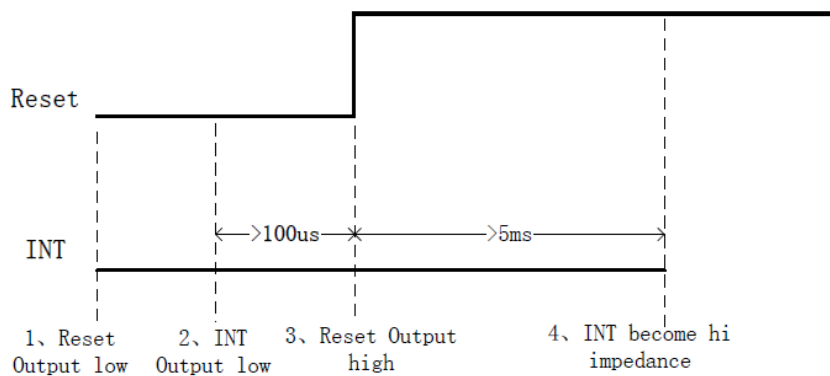

Fig.8(b) Timing of setting slave address

Data Transmission

(ex: slave address is 0xBA/0xBB)

Communication is always initiated by master, A high-to-low transition of SDA with SCL high is a start condition.

All addressing signal are serially transmitted to and from on bus in 8-bit word. This module sends a “0” to acknowledge when the addressing word is 0xBA/BB (or 0x28/0x29). This happens during the ninth clock cycle. If the slave address is not matched, this module will stay in idle state.

The data words are serially transmitted to and from in 9-bit formation: 8-bit data+1-bit ACK or NACK sent by module. Data changes during SCL low periods & keeps valid during SCL high.

A low-to-high transition of SDA with SCL high is a stop condition.

Write Data to module

(ex: slave address is 0xBA/0xBB)

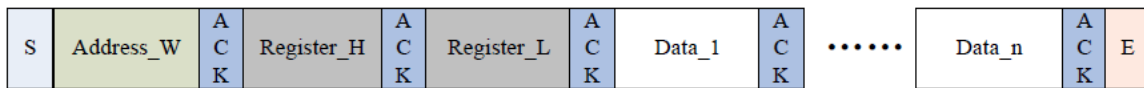

Please check the above figure, master start the communication first, and then sends device address 0xBA preparing for a write operation.

After receiving ACK from module, master sends out 16-bit register address, and then the data word in 8-bit, which is going to be wrote into module.

The address pointer of module will automatically increase one after one byte writing, so master can sequentially write in one operation. When operation finished, master stop the communication.

Read Data from module

(ex: slave address is 0xBA/0xBB)

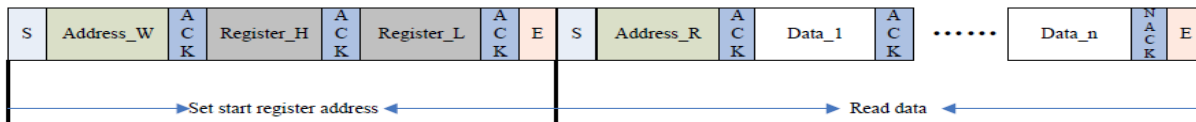

Please check the above figure, master start the communication first, and then sends device address 0xBA for a write operation.

After receiving ACK from module, master sends out 16-bit register address, to set the address pointer of module. After receiving ACK, master produce start signal once again & send device address 0xBB , then read data word from module in 8-bit.

Module also supports sequential read operation, and the default setting is sequential read mode. Master shall send out ACK after every byte reading successfully but NACK after the last one. Then sends stop signal to finish the communication.

REGISTER INFORMATION OF MODULE

a) Real Time Order

(Write Only)

Addr	Name	bit7	bit6	bit5	bit4	bit3	bit2	bit1	bit0
0x8040	Command	0: read coordinate 1: read diff data or raw data 2: software reset3:baseline update 4: baseline calibration 5: screen off 3&4 are still internal test							

b) Configuration Information

(R/W)

	Config Data	bit7	bit6	bit5	bit4	bit3	bit2	bit1	bit0
0x8047	Config_ Version	Version of the configuration							
0x8048	X Output Max (Low Byte)	Resolution of X axis							
0x8049	X Output Max (High Byte)								
0x804A	Y Output Max (Low Byte)	Resolution of Y axis							
0x804B	Y Output Max (High Byte)								
0x804C	Touch Number	Reserved				Touch number: 1~5			
0x804D	Module_ Switch1	Reserved		Stretch_rank		X2Y	Reser ved	INT trigger method 00: rising edge trigger 01: falling edge trigger	

						02: low level enquiry 03: high level enquiry
0x804E	Module_switch2	Reserved				
0x804F	Shake_Count	Reserved			Finger shake count	
0x8050	Filter	First_Filter	Normal_Filter (filtering value of original coordinate window, coefficient is 1)			
0x8051	Large_Touch	Number of touch in large area				
0x8052	Noise_Reduction	Reserved			Value of noise elimination (coefficient is 1, 0~15)	
0x8053	Screen_Touch_Level	Threshold of touch grow out of nothing				
0x8054	Screen_Leave_Level	Threshold of touch grow out of nothing				
0x8055	Low_Power_Control	Reserved			Time to low power consumption (0~15s)	
0x8056	Refresh_Rate	Reserved			Coordinate report rate (Cycle: 5+N ms)	
0x8057	x_threshold	Reserved				
0x8058	y_threshold					
0x8059	X_Speed_Limit	Reserved				
0x805A	Y_Speed_Limit					
0x805B	Space	Blank area of boarder-top (coefficient is 32)			Blank area of Boarder-bottom (coefficient is 32)	
0x805C		Blank area of boarder-left (coefficient is 32)			Blank area of Boarder-right (coefficient is 32)	
0x805D	Stretch_Rate	Reserved			Level of weak stretch (Stretch X/16 Pitch) (beta version is valid, published version is not)	
0x805E	Stretch_R0	Interval 1 coefficient				
0x805F	Stretch_R1	Interval 2 coefficient				
0x8060	Stretch_R2	Interval 3 coefficient				
0x8061	Stretch_RM	All intervals base number				
0x8062	Drv_GroupA_Num	All_Driving	Reserved		Driver_Group_A_number	
0x8063	Drv_GroupB_	Reserved			Driver_Group_B_number	

	Num				
0x8064	Sensor_Num	Sensor_Group_B_Number		Sensor_Group_A_Number	
0x8065	FreqA_factor	Driver frequency double frequency coefficient of Driver group A GroupA_Frequency = Multiplier factor * baseband			
0x8066	FreqB_factor	Driver frequency double frequency coefficient of Driver group B GroupB_Frequency = Multiplier factor * baseband			
0x8067	Pannel_BitFreqL	Baseband of Driver group A/B (1526HZ<baseband<14600Hz)			
0x8068	Pannel_BitFreqH				
0x8069	Pannel_Sensor_TimeL	Time interval of the neighbouring two driving signal (Unit: us), Reserved.			
0x806A	Pannel_Sensor_TimeH				
0x806B	Pannel_Tx_Gain	Reserved		Pannel_Drv_output_R 4 gears	Pannel_DAC_Gain 0:Gain maximum 7: Gain minimum
0x806C	Pannel_Rx_Gain	Pannel_PG_A_C	Pannel_PGA_R	Pannel_Rx_Vcmi (4 gears)	Pannel_PGA_Gain (8 gears)
0x806D	Pannel_Dump_Shift	Reserved		Magnification coefficient of original value (The Nth power of 2)	
0x806E	Drv_Frame_Control	Reserved	SubFrame_DrvNum		Repeat_Num
0x806F	NC	Reserved			
0x8070	NC	Reserved			
0x8071	NC	Reserved			
0x8072	Stylus_Tx_Gain	Undefined (invalid when stylus_priority=0)			
0x8073	Stylus_Rx_Gain	Undefined (invalid when stylus_priority=0)			
0x8074	Stylus_Dump_Shift	Magnification coefficient of original value (The Nth power of 2), Reserved			
0x8075	Stylus_Driver_Touch_Level	Stylus effective threshold (driving), Reserved			
0x8076	Stylus_Sensor_Touch_Level	Stylus effective threshold (sensing), Reserved			
0x8077	Stylus_Control	Pen mode escape time out period (Unit: Sec)			
0x8078	Base_reduce	S-Style improve quantity		Reserved	
0x8079	NC	Reserved			

0x807A	Freq_Hopping_Start	Frequency hopping start frequency (Unit: 2KHz, 50 means 100KHz)		
0x807B	Freq_Hopping_End	Frequency hopping stop frequency (Unit: 2KHz, 150 means 300KHz)		
0x807C	Noise_Detect_Times	Detect_Stay_Times	Detect_Confirm_Times	
0x807D	Hopping_Flag	Hopping_En	Reserved	Detect_Time_Out
0x807E	Hopping_Threshold	Large_Noise_Threshold		Hopping_Hit_Threshold
0x807F	Noise_Threshold	Threshold of noise level		
0x8080	NC	Reserved		
0x8081	NC	Reserved		
0x8082	Hopping_seg1_BitFreqL	Frequency hopping segment band 1 central frequency (for driver A/B)		
0x8083	Hopping_seg1_BitFreqH			
0x8084	Hopping_seg1_Factor	Frequency hopping segment 1 central frequency coefficient		
0x8085	Hopping_seg2_BitFreqL	Frequency hopping segment band 2 central frequency (for driver A/B)		
0x8086	Hopping_seg2_BitFreqH			
0x8087	Hopping_seg2_Factor	Frequency hopping segment 2 central frequency coefficient		
0x8088	Hopping_seg3_BitFreqL	Frequency hopping segment band 3 central frequency (for driver A/B)		
0x8089	Hopping_seg3_BitFreqH			
0x808A	Hopping_seg3_Factor	Frequency hopping segment 3 central frequency coefficient		
0x808B	Hopping_seg4_BitFreqL	Frequency hopping segment band 4 central frequency (for driver A/B)		
0x808C	Hopping_seg4_			

	BitFreqH		
0x808D	Hopping_seg4_Factor	Frequency hopping segment 4 central frequency coefficient	
0x808E	Hopping_seg5_BitFreqL	Frequency hopping segment band 5 central frequency (for driver A/B)	
0x808F	Hopping_seg5_BitFreqH		
0x8090	Hopping_seg5_Factor	Frequency hopping segment 5 central frequency coefficient	
0x8091	NC	Reserved	
0x8092	NC	Reserved	
0x8093	Key 1	Key 1 Position: 0-255 valid (0 means no touch, it means independent touch key when 4 of the keys are 8 multiples)	
0x8094	Key 2	Key 2 position	
0x8095	Key 3	Key 3 position	
0x8096	Key 4	Key 4 position	
0x8097	Key_Area	Time limit for long press(1~16 s)	Touch valid interval setting: 0-15 valid
0x8098	Key_Touch_Level	Key threshold of touch key	
0x8099	Key_Leave_Level	Key threshold of touch key	
0x809A	Key_Sens	KeySens_1(sensitivity coefficient of key 1, same below)	KeySens_2
0x809B	Key_Sens	KeySens_3	KeySens_4
0x809C	Key_Restrain	Finger from screen left after inhibition of key time(Unit:100ms,0 means 600ms)	The independent button pro key inhibition parameters
0x809D	NC	Reserved	
0x809E	NC	Reserved	
0x809F	NC	Reserved	
0x80A0	NC	Reserved	
0x80A1	NC	Reserved	
0x80A2	Proximity_Drv_Select	Drv_Start_Ch (start channel of driving direction)	Drv_End_Ch (End channel)
0x80A3	Proximity_Sens_Select	Sens_Start_Ch (start channel of sensing direction)	Sens_End_Ch (End channel)
0x80A4	Proximity_Touch_Level	Proximity effective threshold value	
0x80A5	Proximity_Leave_Level	Proximity ineffective threshold value	

0x80A6	Proximity_Sample_Add_Times	Frequency multiplication of proximity sensing channel.
0x80A7	Proximity_Sample_Dec_ValL	Sample value minus this value (16 bit), and accumulate, low byte.
0x80A8	Proximity_Sample_Dec_ValH	Sample value minus this value (16 bit), and accumulate, high byte.
0x80A9	Proximity_Leave_Shake_Count	exit proximity jitter count
0x80AA	Self_Cap_Tx_gain	self-capacitance sends gains
0x80AB	Self_Cap_Rx_gain	self-capacitance receive gains
0x80AC	Self_Cap_Dump_Shift	Magnification coefficient of original value of self-capacitance (The Nth power of 2)
0x80AD	SCap_Diff_Up_Level_Drv	Self capacitance suppress floating rising threshold (driving direction)
0x80AE	Scap_Merge_Touch_Level_Drv	Self-capacitance Touch Level (driving direction)
0x80AF	SCap_Pulse_TimeL	Self-capacitance sampling time (low byte)
0x80B0	SCap_Pulse_TimeH	Self-capacitance sampling time (high byte)
0x80B1	SCap_Diff_Up_Level_Sen	Self capacitance suppress floating rising threshold (sensing direction)
0x80B2	Scap_Merge_Touch_Level_Sen	Self-capacitance Touch Level (sensing direction)
0x80B3	NC	Reserved
0x80B4	NC	Reserved
0x80B5	NC	Reserved
0x80B6	NC	Reserved
0x80B7 ~ 0x80C4	Sensor_CH0~ Sensor_CH13	ITO Sensor corresponding chip channel number
0x80C5 ~ 0x80D4	NC	Reserved
0x80D5 ~ 0x80EE	Driver_CH0~ Driver_CH25	ITO Driver corresponding chip channel number
0x80EF ~	NC	Reserved

0x80FE		
0x80FF	Config_Chksum	configuration information verify (the complement number of total byte from 0x8047 to 0x80FE)
0x8100	Config_Fresh	signal of updated configuration (the host writes)

c) Coordinates Information

Addr	Access	bit7	bit6	bit5	bit4	bit3	bit2	bit1	bit0
0x8140	R	Product ID (first byte, ASCII)							
0x8141	R	Product ID (second byte, ASCII)							
0x8142	R	Product ID (third byte, ASCII)							
0x8143	R	Product ID (forth byte, ASCII)							
0x8144	R	Firmware version (HEX.low byte)							
0x8145	R	Firmware version (HEX.high byte)							
0x8146	R	x coordinate resolution (low byte)							
0x8147	R	x coordinate resolution (high byte)							
0x8148	R	y coordinate resolution (low byte)							
0x8149	R	y coordinate resolution (high byte)							
0x814A	R	Vendor_id (current module option information)							
0x814B	R	Reserved							
0x814C	R	Reserved							
0x814D	R	Reserved							
0x814E	R/W	buffer status	large detect	Reserved			number of touch points		
0x814F	R	track id							
0x8150	R	point 1 x coordinate (low byte)							
0x8151	R	point 1 x coordinate (high byte)							
0x8152	R	point 1 y coordinate (low byte)							
0x8153	R	point 1 y coordinate (high byte)							
0x8154	R	Point 1 size (low byte)							
0x8155	R	point 1 size (high byte)							
0x8156	R	Reserved							
0x8157	R	track id							
0x8158	R	point 2 x coordinate (low byte)							
0x8159	R	point 2 x coordinate (high byte)							
0x815A	R	point 2 y coordinate (low byte)							
0x815B	R	point 2 y coordinate (high byte)							
0x815C	R	point 2 size (low byte)							
0x815D	R	point 2 size (high byte)							
0x815E	R	Reserved							

0x815F	R	track id
0x8160	R	point 3 x coordinate (low byte)
0x8161	R	point 3 x coordinate (high byte)
0x8162	R	point 3 y coordinate (low byte)
0x8163	R	point 3 y coordinate (high byte)
0x8164	R	point 3 size (low byte)
0x8165	R	point 3 size (high byte)
0x8166	R	Reserved
0x8167	R	track id
0x8168	R	point 4 x coordinate (low byte)
0x8169	R	point 4 x coordinate (high byte)
0x816A	R	point 4 y coordinate (low byte)
0x816B	R	point 4 y coordinate (high byte)
0x816C	R	point 4 size (low byte)
0x816D	R	point 4 size (high byte)
0x816E	R	Reserved
0x816F	R	track id
0x8170	R	point 5 x coordinate (low byte)
0x8171	R	point 5 x coordinate (high byte)
0x8172	R	point 5 y coordinate (low byte)
0x8173	R	point 5 y coordinate (high byte)
0x8174	R	point 5 size (low byte)
0x8175	R	point 5 size (high byte)
0x8176	R	Reserved
0x8177	R	Reserved

FUNCTION MODE

Working Mode

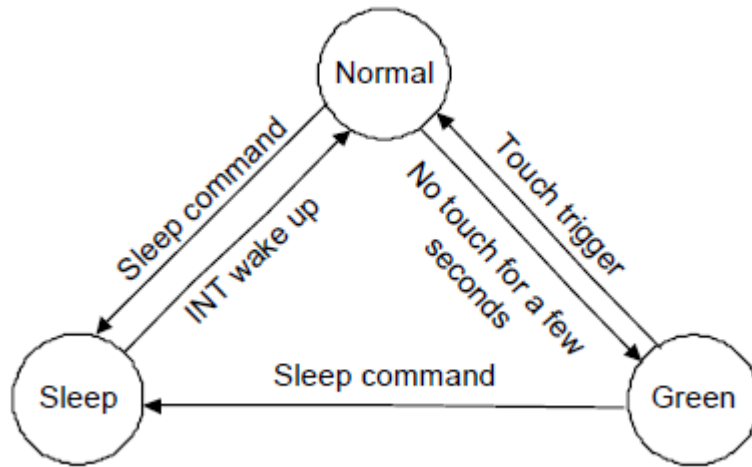

a) Normal Mode

When module is in Normal mode, touch scanning period is about 7ms ~ 10ms depending on the setting. The chip will automatically enter into Green mode if no touch for short time within 0~15s depending on setting and the step is 1s.

b) Green Mode

In Green mode, the touch scanning cycle is fixed as 40ms. It will automatically enter into Normal mode if any touch is detected.

c) Sleep Mode

For a lower consumption, Master can ask module to enter Sleep mode through I2C command (before the command, please drive low to INT pin). Drive high to the INT pin of module 2~5ms will make module return back to normal mode.

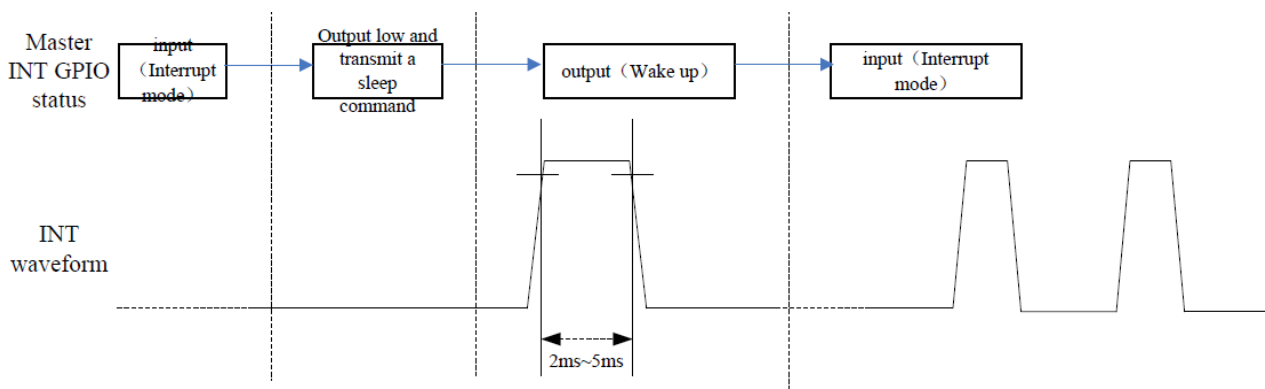

Pulse Calling

Module will inform master to read coordinate information only when touch event happen, in order to lighten the burden of master CPU. The master CPU will set trigger mode by register "INT". "0" means rising edge trigger, in this mode module will output a rising edge hopping in INT, to inform CPU; "1" means falling edge trigger.

Sleep Mode

When the display is turned off or in any circumstance that operation of touch panel is not necessary, master can set module be in Sleep mode through I2C command. The master can wake up module by outputting high to INT pin & keeping 2-5ms.

Frequency Hopping Function

This module has very strong anti-interference hardware, when the driver spectrum of module overlaid with spectrum of noise signal, it can be switch to another frequency by self-adaption frequency hopping mechanism, to avoid interference.

Automatic Calibration

a) Initialization Calibration

Different temperature, humidity and physical structure will affect the sensor's baseline. According to environmental situation module will update the baseline automatically in initialized 200ms.

b) Automatic Temperature Drift

Slow change of temperature, humidity or dust and other environmental factors will also affect the sensor's baseline. module calculates and analyzes historical data, and compare to the current data variation. Base on this, the baseline will be calibration automatically.

For more information, refer to the data sheet GT911:

https://www.lcd-module.de/fileadmin/eng/pdf/zubehoer/GT911%20Datasheet_English%2020150625_Rev10.pdf.

RELIABILITY CONDITION

No change on display and in operation under the following test condition.
 Condition: Unless otherwise specified, tests will be conducted under the following condition.
 Temperature: 20±5°C.
 Humidity: 65±5%RH%.
 Tests will be not conducted under functioning state.

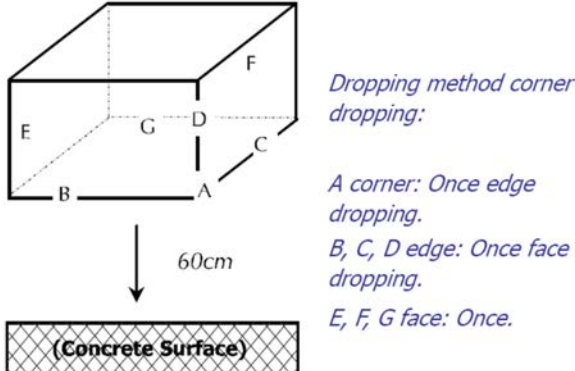
No.	Parameter	Condition	Notes
1	High Temperature Operating	70°C±2°C, 240hrs (Operation state).	
2	Low Temperature Operating	-20°C±2°C, 240hrs (Operation state).	1
3	High Temperature Storage	80°C±2°C, 240hrs.	2
4	Low Temperature Storage	-30°C±2°C, 240hrs.	1,2
5	High Temperature and High Humidity Operation Test	60°C±2°C, 90%RH, 240hrs.	1,2
6	Vibration Test	Total fixed amplitude: 1.5mm. Vibration Frequency: 10~55Hz. One cycle 60 seconds to 3 direction of X, Y, Z each 15 minutes.	3
7	Drop Test	<p>To be measured after dropping from 60cm high on the concrete surface in packing state.</p> 	

- Notes: 1. No dew condensation to be observed.
 2. The function test shall be conducted after 4 hours storage at the normal temperature and humidity after removed from the test chamber.
 3. Vibration test will be conducted to the product itself without putting I in a container.

QUALITY UNITS

INSPECTION METHOD

An appearance inspection should be conducted at 30 cm or more distance/height from the inspector's eye sight to the LCD module surface under fluorescent light. The distance between LCD and fluorescent lamps should be 100 cm or more. Viewing angle for inspection is 40° from vertical against LCD.

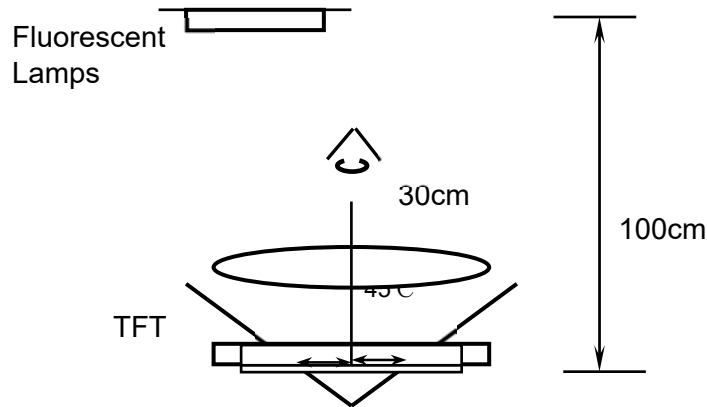

QUALITY LEVEL

The AQL for major and minor defects is defined as follows:

Partition	Definition	AQL
Major defect	Functional defective in product.	0.25
Minor defect	Meet all functions of product but have some cosmetic defective	0.65

DEFINITION

The environmental condition of inspection

- 1) Ambient temperature : 22°C±5°C, 65±20%RH
- 2) Function inspection : less than 300Lux
- 3) Visual inspection : 750±150Lux

DEFINITION OF DOT DEFECT

The size of a defective dot over 1/2 of whole dot, and all of bright dot or dark dot defect must be visible through ND 5% filter.

1) Bright dot

Dots appear bright and unchanged in size in which LCD Cell is displaying under black pattern.

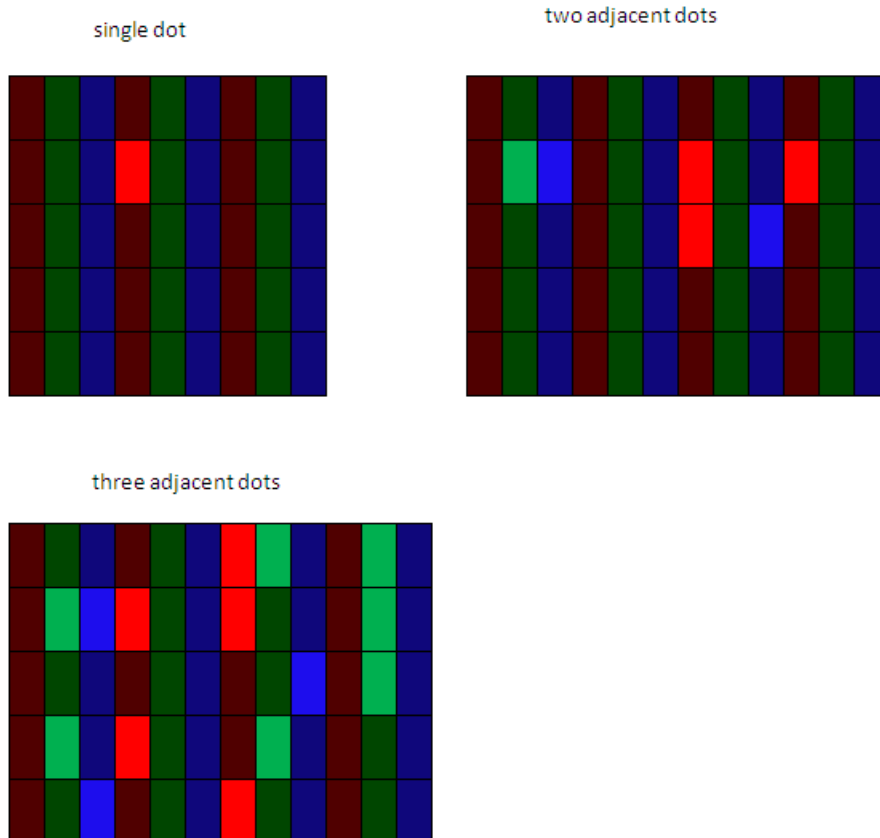

2) Dark dot

The same definition of bright dot, but always display dark in white pattern

3) The usage of ND 5%

Use the ND 5% to cover bright dot within 2s, it should be judged OK if it's invisible.

4) Crowded dot defect

In the area of 10 x10mm, the Number of $\Phi \leq 0.1\text{mm}$ reaches 3 or More (Not allowed)

5) Crowded Line defect

In the area of 10 x10mm, the Number of $W \leq 0.02\text{mm}$ reaches 2 or More (Not allowed)

VISUAL INSPECTION

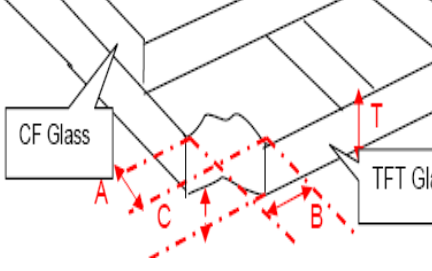
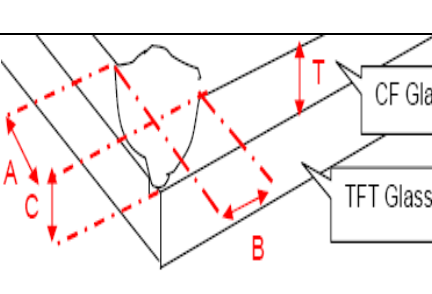
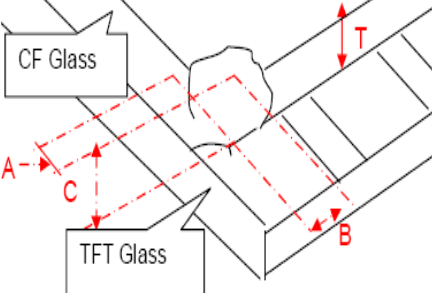
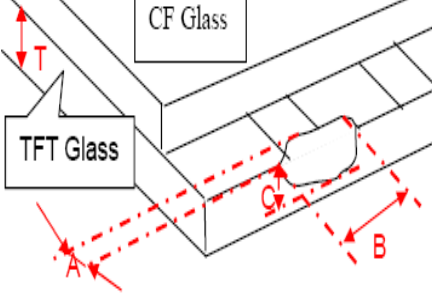
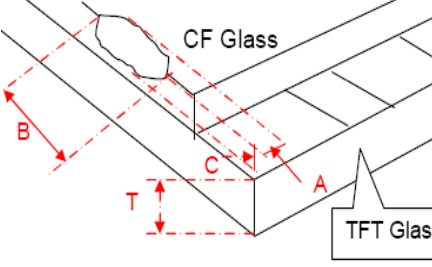
Defect	Inspection	Criteria
<p>1 Corner Broken (Minor)</p>		<p>1. $A \leq 2.0$ mm , $B \leq 2.0$ mm , $C \leq T$ Ignore 2. $A > 2.0$ mm , or $B > 2.0$ mm Not allowed</p>
<p>2 Corner Broken (Minor)</p>		<p>1. $A \leq 1.5$ mm , $B \leq 1.5$ mm , $C \leq T$ Ignore 2. $A > 1.5$ mm , or $B > 1.5$ mm Not allowed 3. To be applied to both CF and TFT glass</p>
<p>3 Corner Broken (Minor)</p>		<p>1. $A \leq 1.5$ mm , $B \leq 1.5$ mm , $C \leq T$ Ignore 2. $A > 1.5$ mm , or $B > 1.5$ mm Not allowed 3. To be applied to both CF and TFT glass</p>
<p>4 Pad Broken (Minor)</p>		<p>1. $A \leq 0.8$ mm, $C \leq T$ Ignore B Length Ignore 2. $A > 0.8$ mm, Not allowed</p>
<p>5 Side Broken (Minor)</p>		<p>1. $A \leq 0.8$ mm, $C \leq T$ Ignore B Length Ignore 2. $A > 0.8$ mm, Not allowed</p>

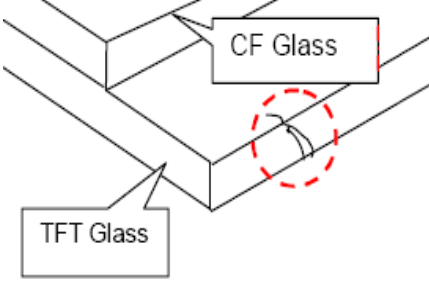
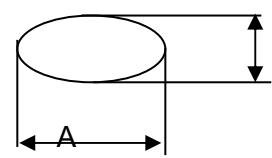
<p>6 Glass crack (Major)</p>		<p>Not allowed</p>																				
<p>7 (Minor)</p>	<p>Spots on polarizer or LCD</p>  <p>Φ= Max a or b</p>	<p>Size 4.7" or Below 4.7"</p> <p>Note:</p> <table border="1" data-bbox="901 750 1484 996"> <thead> <tr> <th>Dimensions</th> <th>Acceptable Numbers</th> </tr> </thead> <tbody> <tr> <td>Φ≤0.1mm</td> <td>Ignore , *1</td> </tr> <tr> <td>0.1mm < Φ ≤ 0.20mm</td> <td>2; *1</td> </tr> <tr> <td>0.2mm < Φ ≤ 0.30mm</td> <td>1</td> </tr> <tr> <td>Φ > 0.30mm</td> <td>0</td> </tr> </tbody> </table> <p>*1: Crowded dot defect Not allowed *2: The distance between dot defects should be more than 5MM *3: Judge by negative-film card</p>	Dimensions	Acceptable Numbers	Φ≤0.1mm	Ignore , *1	0.1mm < Φ ≤ 0.20mm	2; *1	0.2mm < Φ ≤ 0.30mm	1	Φ > 0.30mm	0										
Dimensions	Acceptable Numbers																					
Φ≤0.1mm	Ignore , *1																					
0.1mm < Φ ≤ 0.20mm	2; *1																					
0.2mm < Φ ≤ 0.30mm	1																					
Φ > 0.30mm	0																					
<p>8 (Minor)</p>	<p>Scatched ; Fiber</p>	<p>Scratch :</p> <table border="1" data-bbox="901 1187 1484 1500"> <thead> <tr> <th>Dimensions</th> <th>Acceptable Numbers</th> </tr> </thead> <tbody> <tr> <td>W≤0.03mm</td> <td>Ignore , *1</td> </tr> <tr> <td>L≤5 mm 0.03mm < W ≤ 0.05mm</td> <td>2, *2</td> </tr> <tr> <td>L≤5 mm 0.05mm < W ≤ 0.1mm</td> <td>1</td> </tr> <tr> <td>L≥5 mm or W≥0.1 mm</td> <td>0</td> </tr> </tbody> </table> <p>Fiber:</p> <table border="1" data-bbox="901 1568 1484 1881"> <thead> <tr> <th>Size</th> <th>Acceptable Numbers</th> </tr> </thead> <tbody> <tr> <td>W≤0.03mm</td> <td>Ignore , *1</td> </tr> <tr> <td>L≤3 mm 0.03 < W ≤ 0.05mm</td> <td>2; *2</td> </tr> <tr> <td>L≤5 mm 0.03 < W ≤ 0.05mm</td> <td>1</td> </tr> <tr> <td colspan="2">Beyond Above, Not Allowed</td> </tr> </tbody> </table> <p>Note: *1: Crowded Line defect Not allowed *2 The distance between dot defects should be more 5MM apart *3: Judge by negative-film card</p>	Dimensions	Acceptable Numbers	W≤0.03mm	Ignore , *1	L≤5 mm 0.03mm < W ≤ 0.05mm	2, *2	L≤5 mm 0.05mm < W ≤ 0.1mm	1	L≥5 mm or W≥0.1 mm	0	Size	Acceptable Numbers	W≤0.03mm	Ignore , *1	L≤3 mm 0.03 < W ≤ 0.05mm	2; *2	L≤5 mm 0.03 < W ≤ 0.05mm	1	Beyond Above, Not Allowed	
Dimensions	Acceptable Numbers																					
W≤0.03mm	Ignore , *1																					
L≤5 mm 0.03mm < W ≤ 0.05mm	2, *2																					
L≤5 mm 0.05mm < W ≤ 0.1mm	1																					
L≥5 mm or W≥0.1 mm	0																					
Size	Acceptable Numbers																					
W≤0.03mm	Ignore , *1																					
L≤3 mm 0.03 < W ≤ 0.05mm	2; *2																					
L≤5 mm 0.03 < W ≤ 0.05mm	1																					
Beyond Above, Not Allowed																						

9 (Major)	Envelop silicon on glass	1. ITO non envelop silicon reject 2. Silicon area not match with document request reject 3. Silicon not cover with all ITO reject 4. Glue wet to the LCD upper POL or the bottom POL. And the connector over the LCD PIN. (Include FFC、 FPC...etc) reject
10 (Major)	Keep out light cover/ protection cover	1. Miss the cover reject
11 (Major)	TCP IC/ FPC	1. Scratch、 the line broken off reject 2. The PIN oxidation, broken off, dirty, bend, distortion reject 3. FPC protection cover fix no good or deflection over the drawing request reject
12 (Major)	Backlight	1. The size don't match with the drawing. reject 2. Dirty, finger mark reject 3. Scald reject
13 (Major)	Weld	1. tack weld reject 2. welding shifting less than 1/3 FPC pin 3. welding short out reject 4. very little or too much tin reject 5. tin seat $\leq 0.13\text{mm}$ 6. FPC cock reject
13 (Minor)	LCD rainbow	1. area $> 1/4$ LCD display area reject 2. visible at display reject

7.5 Electronic Inspection Standard:

Defect	Inspection	Criteria										
1 (Minor)	Black/White spot/Bubble .etc.	Size 4.7" or Below 4.7"										
		<table border="1"> <thead> <tr> <th>Dimensions</th> <th>Acceptable Numbers</th> </tr> </thead> <tbody> <tr> <td>$\Phi \leq 0.1\text{mm}$</td> <td>Ignore, *1</td> </tr> <tr> <td>$0.1\text{mm} < \Phi \leq 0.20\text{mm}$</td> <td>2; *1</td> </tr> <tr> <td>$0.2\text{mm} < \Phi \leq 0.30\text{mm}$</td> <td>1</td> </tr> <tr> <td>$\Phi > 0.30\text{mm}$</td> <td>0</td> </tr> </tbody> </table>	Dimensions	Acceptable Numbers	$\Phi \leq 0.1\text{mm}$	Ignore , *1	$0.1\text{mm} < \Phi \leq 0.20\text{mm}$	2 ; *1	$0.2\text{mm} < \Phi \leq 0.30\text{mm}$	1	$\Phi > 0.30\text{mm}$	0
		Dimensions	Acceptable Numbers									
		$\Phi \leq 0.1\text{mm}$	Ignore , *1									
		$0.1\text{mm} < \Phi \leq 0.20\text{mm}$	2 ; *1									
$0.2\text{mm} < \Phi \leq 0.30\text{mm}$	1											
$\Phi > 0.30\text{mm}$	0											
Note:												
*1: Crowded dot defect Not allowed												

		<p>*2.The distance between dot defects should be more than 5MM</p> <p>*3:Judge by negative-film card</p>																		
2 (Minor)	Scratched ; Fiber	<p>Scrach:</p> <table border="1"> <thead> <tr> <th>Dimensions</th> <th>Acceptable Numbers</th> </tr> </thead> <tbody> <tr> <td>W≤0.03mm</td> <td>Ignore , *1</td> </tr> <tr> <td>L≤5 mm 0.03mm < W≤0.05mm</td> <td>2, *2</td> </tr> <tr> <td>L≥5 mm or W≥0.05 mm</td> <td>0</td> </tr> </tbody> </table> <p>Fiber:</p> <table border="1"> <thead> <tr> <th>Size</th> <th>Acceptable Numbers</th> </tr> </thead> <tbody> <tr> <td>W≤0.03mm</td> <td>Ignore , *1</td> </tr> <tr> <td>L≤3 mm 0.03 < W≤0.05mm</td> <td>2; *2</td> </tr> <tr> <td>L≤5 mm 0.03 < W≤0.05mm</td> <td>1</td> </tr> <tr> <td colspan="2">Beyond Above, Not Allowed</td> </tr> </tbody> </table> <p>Note: *1: Crowded Line defect Not allowed *2 The distance between dot defects should be more 5MM apart *3:Judge by negative-film card</p>	Dimensions	Acceptable Numbers	W≤0.03mm	Ignore , *1	L≤5 mm 0.03mm < W≤0.05mm	2, *2	L≥5 mm or W≥0.05 mm	0	Size	Acceptable Numbers	W≤0.03mm	Ignore , *1	L≤3 mm 0.03 < W≤0.05mm	2; *2	L≤5 mm 0.03 < W≤0.05mm	1	Beyond Above, Not Allowed	
Dimensions	Acceptable Numbers																			
W≤0.03mm	Ignore , *1																			
L≤5 mm 0.03mm < W≤0.05mm	2, *2																			
L≥5 mm or W≥0.05 mm	0																			
Size	Acceptable Numbers																			
W≤0.03mm	Ignore , *1																			
L≤3 mm 0.03 < W≤0.05mm	2; *2																			
L≤5 mm 0.03 < W≤0.05mm	1																			
Beyond Above, Not Allowed																				
3 (Minor)	Bright/dark dot ; Bright dot Caused by foreign Particle	<table border="1"> <thead> <tr> <th>Dimensions</th> <th>Acceptable Numbers</th> </tr> </thead> <tbody> <tr> <td>Single bright dot</td> <td>Invisible by ND5% Filter, Ig If visible N ≤1 & should ap Electronic Inspection Stan</td> </tr> <tr> <td>Two adjacent bright dots</td> <td>reject</td> </tr> <tr> <td>Three adjacent bright dots</td> <td>reject</td> </tr> <tr> <td>Single dark dot</td> <td>≤2</td> </tr> <tr> <td>Two adjacent dark dots</td> <td>≤1</td> </tr> <tr> <td>Three adjacent dark dots</td> <td>reject</td> </tr> </tbody> </table> <p>1:The distance between dot defects should be more 5MM apart 2:Total dots≤2</p>	Dimensions	Acceptable Numbers	Single bright dot	Invisible by ND5% Filter, Ig If visible N ≤1 & should ap Electronic Inspection Stan	Two adjacent bright dots	reject	Three adjacent bright dots	reject	Single dark dot	≤2	Two adjacent dark dots	≤1	Three adjacent dark dots	reject				
Dimensions	Acceptable Numbers																			
Single bright dot	Invisible by ND5% Filter, Ig If visible N ≤1 & should ap Electronic Inspection Stan																			
Two adjacent bright dots	reject																			
Three adjacent bright dots	reject																			
Single dark dot	≤2																			
Two adjacent dark dots	≤1																			
Three adjacent dark dots	reject																			
4 (Major)	Display	<p>1. Missing segment, missing word reject</p> <p>2. Display abnormal, no display. reject</p> <p>3. Viewing angle not right. reject</p> <p>4. Display odds reject</p>																		
5 (Major)	Mura	judge by ND5% filter or limit sample																		

6 (Major)	flicker	judge by ND 5% filter in grey pattern or limit sample
7 (Major)	Electricity parameter (VOP/Current)	Over the production SPEC reject
8 (Major)	Backlight	1.No backlight, the LED died off reject 2. The light odds(Follow the limit sample) reject 3. light leak reject
9 (Major)	Cross talk	Limit sample

PIN DEFINITION

Pin	Interface Mode				ST7789V	Description	
	RGB	8-Bit	16-Bit	SPI			
1	LED-	LED-	LED-	LED-		LED cathode	
2	LED+	LED+	LED+	LED+		LED anode	
3	VDD	VDD	VDD	VDD	VDD	Power input	
4	GND	GND	GND	GND	GND	Ground (0V)	
5	B2/GND	D0	GND	GND	DB0		
6	B3	D1	D0	GND	DB1		
7	B4	D2	D1	GND	DB2		
8	B5	D3	D2	GND	DB3		
9	B6	D4	D3	GND	DB4		
10	B7	D5	D4	GND	DB5		
11	G2	D6	D5	GND	DB6		
12	G3	D7	D6	GND	DB7		
13	G4	GND	D7	GND	DB8		
14	G5	GND	GND	GND	DB9		
15	G6	GND	D8	GND	DB10		
16	G7	GND	D9	GND	DB11		
17	R2/GND	GND	D10	GND	DB12		
18	R3	GND	D11	GND	DB13		
19	R4	GND	D12	GND	DB14		
20	R5	GND	D13	GND	DB15		
21	R6	GND	D14	GND	DB16		
22	R7	GND	D15	GND	DB17		
23	DOTCLK	GND	GND	GND	DOTCLK		Clock signal for RGB interface
24	DE	GND	GND	GND	ENABLE		Data enable signal for RGB interface
25	HSYNC	GND	GND	GND	HSYNC	Horizontal synchronizing	
26	VSYNC	GND	GND	GND	VSYNC	Vertical synchronizing	
27	TE	TE	TE	TE	TE	Tearing effect	
28	CS	CS	CS	CS	CSX	Chip select for serial interface	
29	SDA	GND	GND	SDA	SDA	Serial data in	
30	SDO	dnc	dnc	SDO	SDO	Serial data out / WR	
31	SCL	D/C	D/C	SCL	DCX	L: command, H: data / Clock signal for serial interface	
32	D/C	WR	WR	D/C	WRX	Data/command select pin	
33	RESET	RESET	RESET	RESET	RESET	Reset for display + touch controller	
34	VDD	GND	GND	VDD	IM1+IM2	Interface Mode 1 and 2	
35	VDD	GND	VDD	VDD	IM3	Interface Mode 3	
36	GND	RD	RD	GND	RDX	RD	
37	Touch CLK	Touch CLK	Touch CLK	Touch CLK		Touch serial clock signal (EA TFT028-23AITC only)	
38	Touch SDA	Touch SDA	Touch SDA	Touch SDA		Touch serial data signal (EA TFT028-23AITC only)	
39	Touch INT	Touch INT	Touch INT	Touch INT		Interrupt output (EA TFT028-23AITC only)	

INTERFACE MODE SELECTION

Name	I/O	Description	Connect Pin			
IM3,IM2,IM1 IM0=0	I	The interface mode select.		GND/VDD		
		IM3	IM2+IM1		MPU Interface Mode	Data Pin
		0	0		80-8bit parallel I/F	DB[7:0]
		0	1		4-line 8bit serial I/F	SDA:in/out
		1	0		80-16bit parallel I/F II	DB[17:10], DB[8:1]
1	1	4-line 8bit serial I/F II	SDA:in SDO:out			

Note: For more information please refer to controller's datasheet <https://www.lcd-module.de/fileadmin/eng/pdf/zubehoer/ST7789V.pdf>

For RGB Mode, please select serial mode! First initialize ST7789V in SPI mode, then switch to RGB-Mode with the help of commands. Please refer to the controller's datasheet.

INITIALIZATION EXAMPLE

```

WriteComm(0x01);
Delay(200);

//-----
----//
WriteComm(0x11);
Delay(120); //Delay 120ms
//-----display and color format setting-----
//
WriteComm(0x36);
WriteData(0x00);
WriteComm(0x3a);
WriteData(0x05);
WriteComm(0x21);

//-----ST7789V Frame rate setting-----//
WriteComm(0xb2);
WriteData(0x05);
WriteData(0x05);
WriteData(0x00);
WriteData(0x33);
WriteData(0x33);
WriteComm(0xb7);
WriteData(0x35);
//-----ST7789V Power setting-----//
WriteComm(0xb8);
WriteData(0x2f);
WriteData(0x2b);
WriteData(0x2f);
WriteComm(0xbb);
WriteData(0x2B);
WriteComm(0xc0);
WriteData(0x2c);
WriteComm(0xc2);
WriteData(0x01);
WriteComm(0xc3);
WriteData(0x0b);
WriteComm(0xc4);
WriteData(0x20);
WriteComm(0xc6);
WriteData(0x11);
WriteComm(0xd0);
WriteData(0xa4);
WriteData(0xa1);
WriteComm(0xe8);
WriteData(0x03);
WriteComm(0xe9);
WriteData(0x0d);
WriteData(0x12);
WriteData(0x00);
//-----ST7789V gamma setting-----//
WriteComm(0xe0);
WriteData(0xd0);
WriteData(0x06);
WriteData(0x0b);
WriteData(0x0a);
WriteData(0x09);
WriteData(0x05);

```

```

WriteData(0x2e);
WriteData(0x43);
WriteData(0x44);
WriteData(0x09);
WriteData(0x16);
WriteData(0x15);
WriteData(0x23);
WriteData(0x27);

WriteComm(0xe1);
WriteData(0xd0);
WriteData(0x06);
WriteData(0x0b);
WriteData(0x09);
WriteData(0x08);
WriteData(0x06);
WriteData(0x2e);
WriteData(0x44);
WriteData(0x44);
WriteData(0x3a);
WriteData(0x15);
WriteData(0x15);
WriteData(0x23);
WriteData(0x26);

//-----Init RGB-Mode-----
WriteComm(0x3A); //Interface Pixel Format
WriteData(0x55); //RGB 65K Colors, Control interface 16bit/pixel

WriteComm(0xB0); //RAM access control
WriteData(0x11); //RGB interface access RAM, Display operation RGB interface
WriteData(0xE0); //16 Bit Farbformat R7 auf R0, MSB first, 18 bit bus width,

WriteComm(0xB1); //RGB interfacecontrol
WriteData(0xEF); //Direct RGB mode, RGB DE Mode, Control pins high active
WriteData(0x08); //VSYNC Back porch setting
WriteData(0x14); //HSYNC Back porch setting

//-----Display on-----
WriteComm(0x11);
Delay(120); //Delay 120ms

WriteComm(0x29);
Delay(100);

```

ACCESSORY EA WF030-39S

The 39-pin FFC cable is an all in one connection. It provides all signals for

- TFT interface
- LED backlight
- PCAP touchpanel

EA WF030-39S is a 39-pin ZIFF connector for bottom side contact.

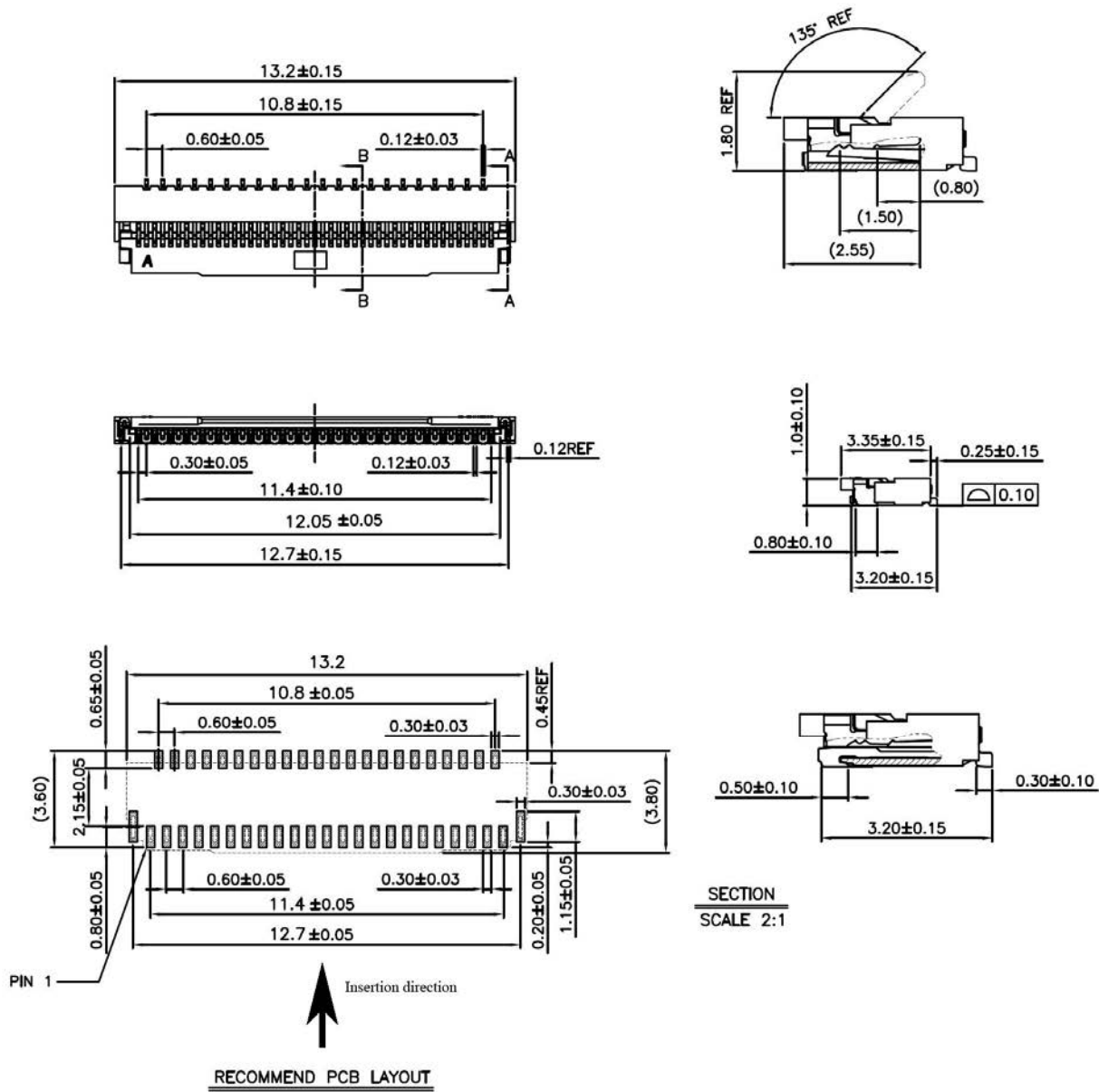

DIMENSIONS

EA TFT028-23AINN

ROHS

Kind suggestion: VA of customer's application should be 0.5mm smaller than LCD VA in each side.

DATE: 2019.01.21
2019.05.24
2019.11.26
2019.11.27
2019.12.03

ISSUE **MODIFY DESCRIPTION** **DATE**

T01 First Issue

T02 Modify the shape of FPC

T03 Modify the shape of FPC

T04 Modify date code and FPC assignment, add the pull tape and double tape

T05 Modify the shape of FPC and voltage of backlight

FPC ASSIGNMENT:

1	LED-	21	DB16
2	LED+	22	DB17
3	VDD	23	DOTCLK
4	GND	24	ENABLE
5	DB0	25	HSYNC
6	DB1	26	VSYNC
7	DB2	27	TE
8	DB3	28	CSX
9	DB4	29	SDA
10	DB5	30	SDO
11	DB6	31	DCX
12	DB7	32	WRX
13	DB8	33	RESET
14	DB9	34	IM1+IM2
15	DB10	35	IM3
16	DB11	36	RDX
17	DB12	37	NC
18	DB13	38	NC
19	DB14	39	NC
20	DB15		

Product of JHD not included
1.5mm double tape and PCB
(此屏模组及客户参考, JHD产品不包括1.5mm厚度面胶及PCB板)

Quotation No.: F-YL19002

Display Type	2.8" TFT-LCD
Display Resolution	NORMALLY BLACK / TRANSMISSIVE (Glare)
Viewing Direction	240*(RGB)*320
LCD Controller/Driver	Free
Logic Voltage	SI7789V
Operation Temperature	2.8V
Storage Temperature	-20°C TO 70°C
Backlight Speciality	-30°C TO 80°C
Reliability test	LED SIDE (WHITE), 9PCS VF=25.2V±1.8V, IF=20mA(constant) ④⑤⑥ Luminous of module is 1000cd/m2(typ)
Remark	Normal IM0 to GND EXTC to VDD

Backlight LED Circuit

Module Speciality

ITEM NO.: EA TFT028-23AINN

PROJECT NO.: EA TFT028-23AINN

Special characteristic (▲): Critical dimension

Safety characteristic (●): Reference dimension

Tolerance unless x.x±0.3 Otherwise specified: x.xx±0.2

THIRD ANGLE PROJECTION

NAME: SIGN

DRAWN: Liao Mao liang

CHECKED: Huang Chao sheng

APPROVED: Lan Li juan

REV: T05

UNIT: mm

SCALE: 1/1

SHEET: 1 OF 2

With Touchpanel EA TFT028-23AITC

