

Reference Specification

Part Description: Chip Coil (Chip Inductors)

MURATA Part No: LQH31MN□□□□03L

RoHS regulation conformity parts.

Technical Dept.

Prepared by

J. Takaoka (Signature)

T.Takaoka (Type)

Approved by

H. Yamada (Signature)

H.Yamada (Type)
Manager

Product Engineering Sec.3
Product Engineering Dept.
EMI Filter Division
Murata Mfg. Co., Ltd.
(Company name / Division)

CHIP COIL(CHIP INDUCTORS) LQH31MN□□□□03L Reference Specification

1.Scope

This reference specification applies to LQH31MN series, Chip coil (Chip Inductors).

2.Part Numbering

(ex) LQ H 31 M N R15 M 0 3 L
 Product ID Structure Dimension Applications Category Inductance Tolerance Features Electrode Packaging
 (L×W) and Characteristics L:Taping

3.Rating

- Operating Temperature Range – 40 °C to + 85 °C
- Storage Temperature Range – 40 °C to + 85 °C

Customer Part Number	MURATA Part Number	Inductance		Q (min.)	DC Resistance (Ω)	Self Resonant Frequency (MHz min.)	Rated Current (mA)
		(μH)	Tolerance				
	LQH31MNR15M03L	0.15	M:±20% K:±10%	20	0.39±40%	250	250
	LQH31MNR15K03L						
	LQH31MNR22M03L	0.22			0.43±40%	250	240
	LQH31MNR22K03L						
	LQH31MNR33M03L	0.33		0.45±40%	250	230	
	LQH31MNR33K03L						
	LQH31MNR47M03L	0.47		0.83±40%	200	215	
	LQH31MNR47K03L						
	LQH31MNR56M03L	0.56		0.61±40%	180	200	
	LQH31MNR56K03L						
	LQH31MNR68M03L	0.68	0.67±40%	160	190		
	LQH31MNR68K03L						
	LQH31MNR82M03L	0.82	0.73±40%	120	185		
	LQH31MNR82K03L						
	LQH31MN1R0M03L	1.0	0.49±30%	100	175		
	LQH31MN1R0K03L						
	LQH31MN1R2M03L	1.2	0.9±30%	90	165		
	LQH31MN1R2K03L						
	LQH31MN1R2J03L						
	LQH31MN1R5M03L	1.5	1.0±30%	75	155		
	LQH31MN1R5K03L						
	LQH31MN1R5J03L						
	LQH31MN1R8M03L	1.8	1.6±30%	60	150		
	LQH31MN1R8K03L						
	LQH31MN1R8J03L						
	LQH31MN2R2M03L	2.2	0.7±30%	50	140		
	LQH31MN2R2K03L						
	LQH31MN2R2J03L						
	LQH31MN2R7M03L	2.7	0.55±30%	43	135		
	LQH31MN2R7K03L						
	LQH31MN2R7J03L						
	LQH31MN3R3M03L	3.3	0.61±30%	38	130		
	LQH31MN3R3K03L						
	LQH31MN3R3J03L						

Customer Part Number	MURATA Part Number	Inductance		Q (min.)	DC Resistance (Ω)	Self Resonant Frequency (MHz min.)	Rated Current (mA)		
	LQH31MN3R9M03L	3.9	M: \pm 20% K: \pm 10% J: \pm 5%	35	1.5 \pm 30%	35	125		
	LQH31MN3R9K03L								
	LQH31MN3R9J03L								
	LQH31MN4R7M03L	4.7					1.7 \pm 30%	31	120
	LQH31MN4R7K03L								
	LQH31MN4R7J03L								
	LQH31MN5R6M03L	5.6					1.8 \pm 30%	28	115
	LQH31MN5R6K03L								
	LQH31MN5R6J03L								
	LQH31MN6R8M03L	6.8					2.0 \pm 30%	25	110
	LQH31MN6R8K03L								
	LQH31MN6R8J03L								
	LQH31MN8R2M03L	8.2			2.2 \pm 30%	23	105		
	LQH31MN8R2K03L								
	LQH31MN8R2J03L								
	LQH31MN100K03L	10	K: \pm 10% J: \pm 5%	40	2.5 \pm 30%	20	100		
	LQH31MN100J03L								
	LQH31MN120K03L	12					2.7 \pm 30%	18	95
	LQH31MN120J03L								
	LQH31MN150K03L	15					3.0 \pm 30%	16	90
	LQH31MN150J03L								
	LQH31MN180K03L	18					3.4 \pm 30%	15	85
	LQH31MN180J03L								
	LQH31MN220K03L	22					3.1 \pm 30%	14	85
	LQH31MN220J03L								
	LQH31MN270K03L	27					3.4 \pm 30%	13	85
	LQH31MN270J03L								
	LQH31MN330K03L	33					3.8 \pm 30%	12	80
	LQH31MN330J03L								
	LQH31MN390K03L	39					7.2 \pm 30%	11	55
	LQH31MN390J03L								
	LQH31MN470K03L	47					8.0 \pm 30%	10	55
	LQH31MN470J03L								
	LQH31MN560K03L	56			8.9 \pm 30%	9.0	50		
	LQH31MN560J03L								
	LQH31MN680K03L	68			9.9 \pm 30%	8.5	50		
	LQH31MN680J03L								
	LQH31MN820K03L	82			11.0 \pm 30%	7.5	45		
	LQH31MN820J03L								
	LQH31MN101K03L	100			12.0 \pm 30%	7.0	45		
	LQH31MN101J03L								

4. Testing Conditions

《Unless otherwise specified》

Temperature : Ordinary Temperature / 15°C to 35°C

Humidity : Ordinary Humidity / 25%(RH) to 85%(RH)

《In case of doubt》

Temperature : 20 °C \pm 2°C

Humidity : 60%(RH) to 70%(RH)

Atmospheric Pressure : 86kPa to 106kPa

5. Appearance and Dimensions

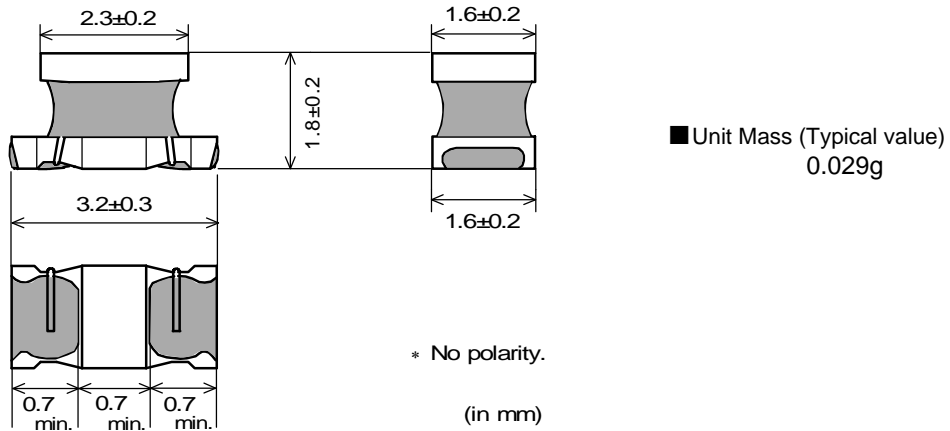

6. Electrical Performance

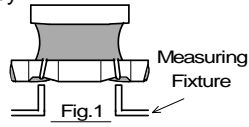
No.	Item	Specification	Test Method
6.1	Inductance	Inductance shall meet item 3.	Measuring Equipment : Agilent 4192A or equivalent Measuring Frequency : 1MHz Measuring Fixture :  Fig.1
6.2	Q	Q shall meet item 3.	Measuring Equipment : Agilent 4192A or equivalent Measuring Frequency : 25.2MHz / 0.15μH ~ 0.82μH 10MHz / 1.0 μH ~ 2.7μH 8MHz / 3.3 μH ~ 8.2μH 5MHz / 10 μH ~ 18μH 2.5MHz / 22 μH ~ 100μH Measuring Fixture : See Fig.1.
6.3	DC Resistance	DC Resistance shall meet item 3.	Measuring Equipment : Digital multi meter
6.4	Self Resonant Frequency(S.R.F)	S.R.F shall meet item 3.	Measuring Equipment : Agilent 4291A or equivalent
6.5	Rated Current	Self temperature rise shall be limited to 20 °C max. Inductance Change : within ± 10%	The rated current is applied.
6.6	Temperature Characteristics	Temperature Coefficient Inductance / 0.15μH ~ 18μH : 150 PPM/ °C±150 PPM / °C 22μH ~ 100μH : 650 PPM/ °C±450 PPM / °C	Temperature coefficient on the basis of step 3 shall meet specification after tested as follows.It shall be subjected to the condition of Table 1, and its inductance shall be measured at each step after reaching the thermal equilibrium and be calculated. <u>Table 1</u> Step1/+20°C ±2°C Step4/+85°C ±2°C Step2/ -25°C ±2°C Step5/+20°C ±2°C Step3/+20°C ±2°C

7.Mechanical Performance

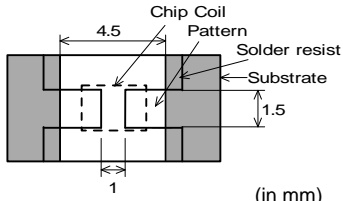
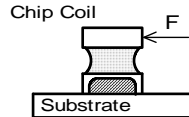
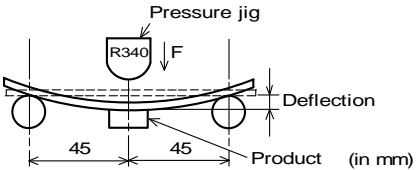
No.	Item	Specification	Test Method
7.1	Shear Test	Chip coil shall not be damaged after tested as test method.	<p>Substrate : Glass-epoxy substrate</p>  <p style="text-align: right;">(in mm)</p> <p>Applied Direction :</p>  <p>Force : 10N Hold Duration : 5s ± 1s</p>
7.2	Bending Test		<p>Substrate : Glass-epoxy substrate (100mm×40mm×1.6mm)</p> <p>Speed of Applying Force : 1mm / s Deflection : 2mm Hold Duration : 30s</p>  <p style="text-align: right;">Product (in mm)</p>
7.3	Vibration		<p>Oscillation Frequency : 10Hz ~ 55Hz ~ 10Hz for 1 min Total Amplitude : 1.5mm Testing Time : A period of 2 hours in each of 3 mutually perpendicular directions. (Total 6 hours)</p>
7.4	Solderability	The wetting area of the electrode shall be at least 90% covered with new solder coating.	<p>Flux: Ethanol solution of rosin, 25(wt)% (Immersed for 5s to 10s) Solder : Sn-3.0Ag-0.5Cu Pre-Heating : 150±10°C / 60 to 90seconds Solder Temperature : 240±5°C Immersion Time : 3±1 s</p>
7.5	Resistance to Soldering Heat	Appearance:No damage Inductance Change : within ±5%	<p>Flux: Ethanol solution of rosin, 25(wt)% (Immersed for 5s to 10s) Solder : Sn-3.0Ag-0.5Cu Pre-Heating: 150±10°C / 60 to 90seconds Solder Temperature: 270±5°C Immersion Time: 10±1 s Then measured after exposure in the room condition for 24±2 hours.</p>

8.Environmental Performance (It shall be soldered on the substrate.)

No.	Item	Specification	Test Method
8.1	Heat Resistance	Appearance : No damage Inductance Change : within $\pm 5\%$ Q Change : within $\pm 20\%$	Temperature : $85\text{ }^\circ\text{C} \pm 2\text{ }^\circ\text{C}$ Time : 1000h (+48h , -0h) Then measured after exposure in the room condition for 24 ± 2 hours.
8.2	Cold Resistance		Temperature : $-40\text{ }^\circ\text{C} \pm 2\text{ }^\circ\text{C}$ Time: 1000h (+48h , -0h) Then measured after exposure in the room condition for 24 ± 2 hours..
8.3	Humidity		Temperature : $40\text{ }^\circ\text{C} \pm 2\text{ }^\circ\text{C}$ Humidity : 90 %(RH) to 95 %(RH) Time : 1000h (+48h , -0h) Then measured after exposure in the room condition for 24 ± 2 hours.
8.4	Temperature Cycle		1 cycle : 1 step : $-40\text{ }^\circ\text{C} \pm 2\text{ }^\circ\text{C} / 30\text{ min} \pm 3\text{ min}$ 2 step : Ordinary temp. / 10 min ~ 15 min 3 step : $+85\text{ }^\circ\text{C} \pm 2\text{ }^\circ\text{C} / 30\text{ min} \pm 3\text{ min}$ 4 step : Ordinary temp. / 10min ~ 15 min Total of 10 cycles Then measured after exposure in the room condition for 24 ± 2 hours.

9. Specification of Packaging

9.1 Appearance and Dimensions of plastic tape

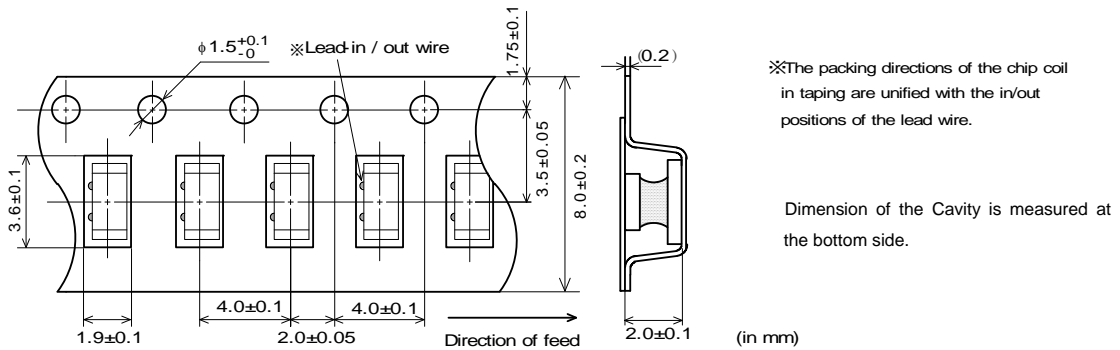

9.2 Specification of Taping

- (1) Packing quantity (standard quantity)
2,000 pcs / reel
- (2) Packing Method
Products shall be packed in the each embossed cavity of plastic tape and sealed by cover tape.
- (3) Sprocket hole
The sprocket holes are to the right as the tape is pulled toward the user.
- (4) Spliced point
Plastic tape and Cover tape has no spliced point.
- (5) Missing components number
Missing components number within 0.1 % of the number per reel or 1 pc., whichever is greater, and are not continuous. The specified quantity per reel is kept.

9.3 Pull Strength

Plastic tape	10N min.
Cover tape	

9.4 Peeling off force of cover tape

Speed of Peeling off	300 mm / min
Peeling off force	0.2N to 0.7N (minimum value is typical)

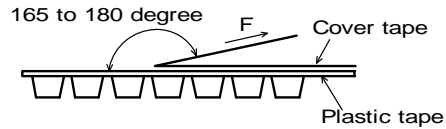

9.5 Dimensions of Leader-tape, Trailer and Reel

There shall be leader-tape (cover tape) and trailer-tape (empty tape) as follows.

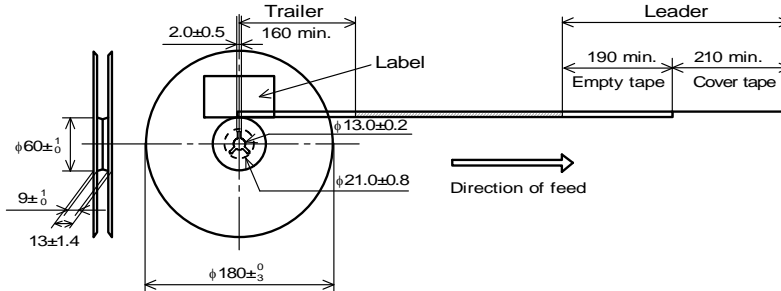

9.6 Marking for reel

Customer part number, MURATA part number; Inspection number(*1), RoHS marking(*2), Quantity etc....

*1) <Expression of Inspection No.>

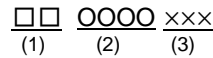

- (1) Factory Code
- (2) Date

First digit : Year / Last digit of year
 Second digit : Month / Jan. to Sep. → 1 to 9, Oct. to Dec. → O, N, D
 Third, Fourth digit : Day

- (3) Serial No.

*2) « Expression of RoHS marking » ROHS - Y (Δ)
 (1) (2)

- (1) RoHS regulation conformity parts.
- (2) MURATA classification number

9.7 Marking for Outside package (corrugated paper box)

Customer name, Purchasing order number, Customer part number, MURATA part number, RoHS marking(*2), Quantity, etc. ...

9.8. Specification of Outer Case

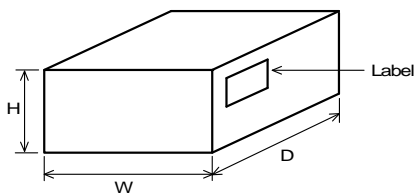

Outer Case Dimensions (mm)			Standard Reel Quantity in Outer Case (Reel)
W	D	H	
186	186	93	5

* Above Outer Case size is typical. It depends on a quantity of an order

10. ⚠ Caution

Limitation of Applications

Please contact us before using our products for the applications listed below which require especially high reliability for the prevention of defects which might directly cause damage to the third party's life, body or property.

- | | |
|-----------------------------------|--|
| (1) Aircraft equipment | (6) Transportation equipment (vehicles, trains, ships, etc.) |
| (2) Aerospace equipment | (7) Traffic signal equipment |
| (3) Undersea equipment | (8) Disaster prevention / crime prevention equipment |
| (4) Power plant control equipment | (9) Data-processing equipment |
| (5) Medical equipment | (10) Applications of similar complexity and /or reliability requirements to the applications listed in the above |

11. Notice

This product is designed for solder mounting.
Please consult us in advance for applying other mounting method such as conductive adhesive.

11.1 Land pattern designing

Recommended land patterns for flow and reflow soldering are as follows:

It has been designed for Electric characteristics and solderability.

Please follow the recommended patterns. Otherwise, their performance which includes electrical performance or solderability may be affected, or result to "position shift" in soldering process.

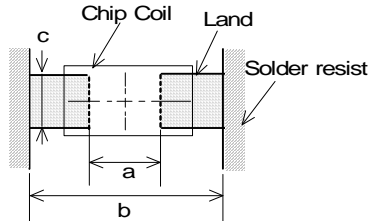

a	1.0
b	4.5
c	1.5

(in mm)

11.2 Flux, Solder

Flux	<ul style="list-style-type: none"> • Use rosin-based flux. • Don't use highly acidic flux with halide content exceeding 0.2(wt)% (chlorine conversion value). • Don't use water-soluble flux.
Solder	<ul style="list-style-type: none"> • Use Sn-3.0Ag-0.5Cu solder • Standard thickness of solder paste : 200 μm to 300 μm

Other flux (except above) Please contact us for details, then use.

11.3 Flow soldering / Reflow soldering conditions

- Pre-heating should be in such a way that the temperature difference between solder and product surface is limited to 150°C max. Cooling into solvent after soldering also should be in such a way that the temperature difference is limited to 100°C max. Insufficient pre-heating may cause cracks on the product, resulting in the deterioration of products quality.
- Standard soldering profile and the limit soldering profile is as follows. The excessive limit soldering conditions may cause leaching of the electrode and / or resulting in the deterioration of product quality.

soldering profile

(1)Flow soldering profile

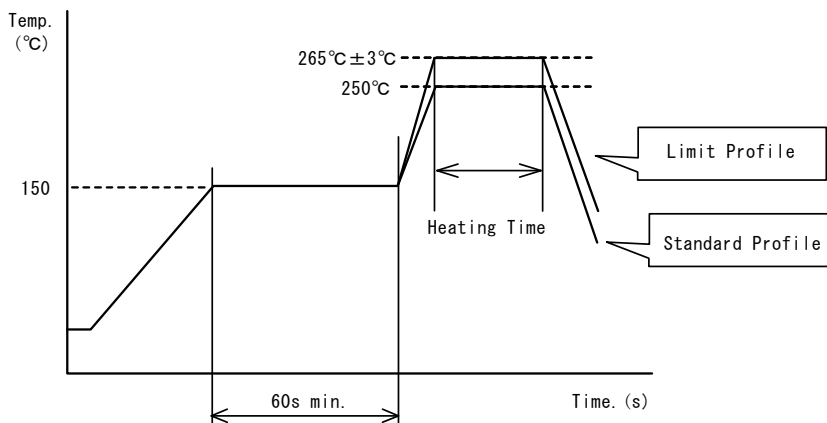

	Standard Profile	Limit Profile
Pre-heating	150°C、60s min.	
Heating	250°C、4s~6s	265°C±3°C、5s
Cycle of flow	2 times	

(2)Reflow soldering profile

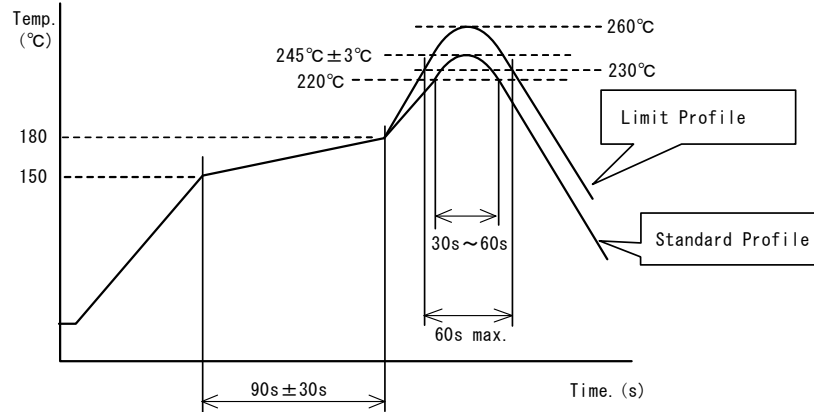

	Standard Profile	Limit Profile
Pre-heating	150~180°C、90s±30s	
Heating	above 220°C、30s~60s	above 230°C、60s max.
Peak temperature	245±3°C	260°C,10s
Cycle of reflow	2 times	2 times

11.4 Reworking with soldering iron.

The following conditions must be strictly followed when using a soldering iron.

Pre-heating	150°C,1 min
Tip temperature	350°C max.
Soldering iron output	80W max.
Tip diameter	φ 3mm max.
Soldering time	3(+1,-0)s
Times	2 times

Note : Do not directly touch the products with the tip of the soldering iron in order to prevent the crack on the products due to the thermal shock.

11.5 Solder Volume

- Solder shall be used not to be exceeded the upper limits as shown below.
- Accordingly increasing the solder volume, the mechanical stress to Chip is also increased. Exceeding solder volume may cause the failure of mechanical or electrical performance.

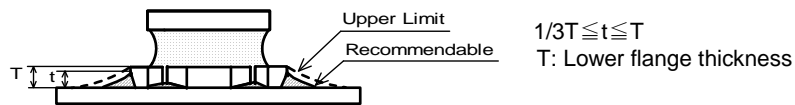

11.6 Product's location

The following shall be considered when designing and laying out P.C.B.'s.

- (1) P.C.B. shall be designed so that products are not subject to the mechanical stress due to warping the board.

[Products direction]

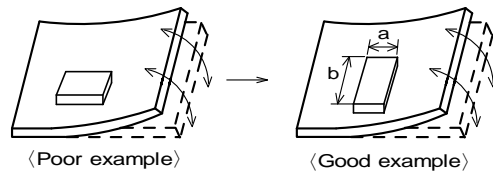

Products shall be located in the sideways direction (Length:a<b) to the mechanical stress.

- (2) Products location on P.C.B. separation
 Products (A,B,C,D) shall be located carefully so that products are not subject to the mechanical stress due to warping the board. Because they may be subjected the mechanical stress in order of $A > C > B \cong D$.

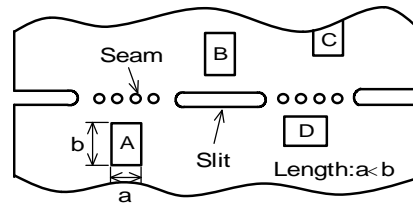

11.7 Cleaning Conditions

Products shall be cleaned on the following conditions.

- (1) Cleaning temperature shall be limited to 60°C max.(40°C max for IPA.)
- (2) Ultrasonic cleaning shall comply with the following conditions with avoiding the resonance phenomenon at the mounted products and P.C.B.
 Power : 20 W / l max. Frequency : 28kHz to 40kHz Time : 5 min max.
- (3) Cleaner
 1. Alcohol type cleaner
 · Isopropyl alcohol (IPA)
 2. Aqueous agent
 · PINE ALPHA ST-100S
- (4) There shall be no residual flux and residual cleaner after cleaning.
 In the case of using aqueous agent, products shall be dried completely after rinse with de-ionized water in order to remove the cleaner.
- (5) Other cleaning
 Please contact us.

11.8 Resin coating

The inductance value may change due to high cure-stress of resin to be used for coating/molding products. An open circuit issue may occur by mechanical stress caused by the resin, amount/cured shape of resin, or operating condition etc. Some resin contains some impurities or chloride possible to generate chlorine by hydrolysis under some operating condition may cause corrosion of wire of coil, leading to open circuit. So, please pay your careful attention when you select resin in case of coating/molding the products with the resin. Prior to use the coating resin, please make sure no reliability issue is observed by evaluating products mounted on your board.

11.9 Caution for use

- Sharp material such as a pair of tweezers or other material such as bristles of cleaning brush, shall not be touched to the winding portion to prevent the breaking of wire.
- Mechanical shock should not be applied to the products mounted on the board to prevent the breaking of the core

11.10 Handling of a substrate

After mounting products on a substrate, do not apply any stress to the product caused by bending or twisting to the substrate when cropping the substrate, inserting and removing a connector from the substrate or tightening screw to the substrate.

Excessive mechanical stress may cause cracking in the product.

Bending

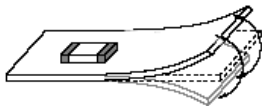

Twisting

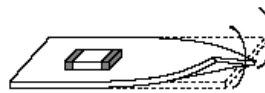

11.11 Storage and Handling Requirements

- (1) Storage period
 Use the products within 12 months after delivered.
 Solderability should be checked if this period is exceeded.
- (2) Storage conditions
 - Products should be stored in the warehouse on the following conditions.
 Temperature : -10 °C to 40 °C
 Humidity : 15 % to 85 % relative humidity No rapid change on temperature and humidity
 The electrode of the products is coated with solder. Don't keep products in corrosive gases such as sulfur, chlorine gas or acid, or it may cause oxidization of electrode, resulting in poor solderability.

- Products should not be stored on bulk packaging condition to prevent the chipping of the core and the breaking of winding wire caused by the collision between the products.
- Products should be stored on the palette for the prevention of the influence from humidity, dust and so on.
- Products should be stored in the warehouse without heat shock, vibration, direct sunlight and so on.

(3) Handling Condition

Care should be taken when transporting or handling product to avoid excessive vibration or mechanical shock.

12.  Note

- (1) Please make sure that your product has been evaluated in view of your specifications with our product being mounted to your product.
- (2) You are requested not to use our product deviating from the reference specifications.
- (3) The contents of this reference specification are subject to change without advance notice. Please approve our product specifications or transact the approval sheet for product specifications before ordering.