

NHD-7.0-800480EF-ASXN#-CTP

TFT (Thin-Film-Transistor) Color Liquid Crystal Display Module

NHD-	Newhaven Display
7.0-	7.0" Diagonal
800480-	800xRGBx480 pixels
EF-	Model
A-	Built-in driver / No Controller
S-	Sunlight Readable
X-	TFT
N-	TN, Wide Temperature
#-	RoHS Compliant
CTP-	Capacitive Touch Panel with Controller

Newhaven Display International, Inc.

2661 Galvin Ct.

Elgin IL, 60124

Ph: 847-844-8795

Fax: 847-844-8796

www.newhavendisplay.com

nhtech@newhavendisplay.com

nhsales@newhavendisplay.com

Document Revision History

Revision	Date	Description	Changed by
0	3/10/16	Initial Release	SB
1	6/30/16	Chromaticity Added	SB
2	8/2/17	CTP Firmware Updated	SB
3	9/15/17	Backlight Characteristics Updated	SB
4	8/14/18	Updated CTP Driver & Panel	SB
5	12/11/18	Updated Mechanical Drawing	TM
6	5/7/19	CTP Timing Note Added	SB
7	12/27/19	CTP Firmware Updated	SB
8	3/9/20	LCD Driver Changed to EK9716	SB

Functions and Features

- 800xRGBx480 resolution
- LED backlight
- 24-bit digital RGB interface
- 16.7M colors
- Sunlight Readable
- Capacitive touch panel with controller
 - 10-Point multi-touch input
 - Gesture input
 - Zoom In/Out
 - Swipe Up/Down/Left/Right

SYMBOL	REVISION	DATE

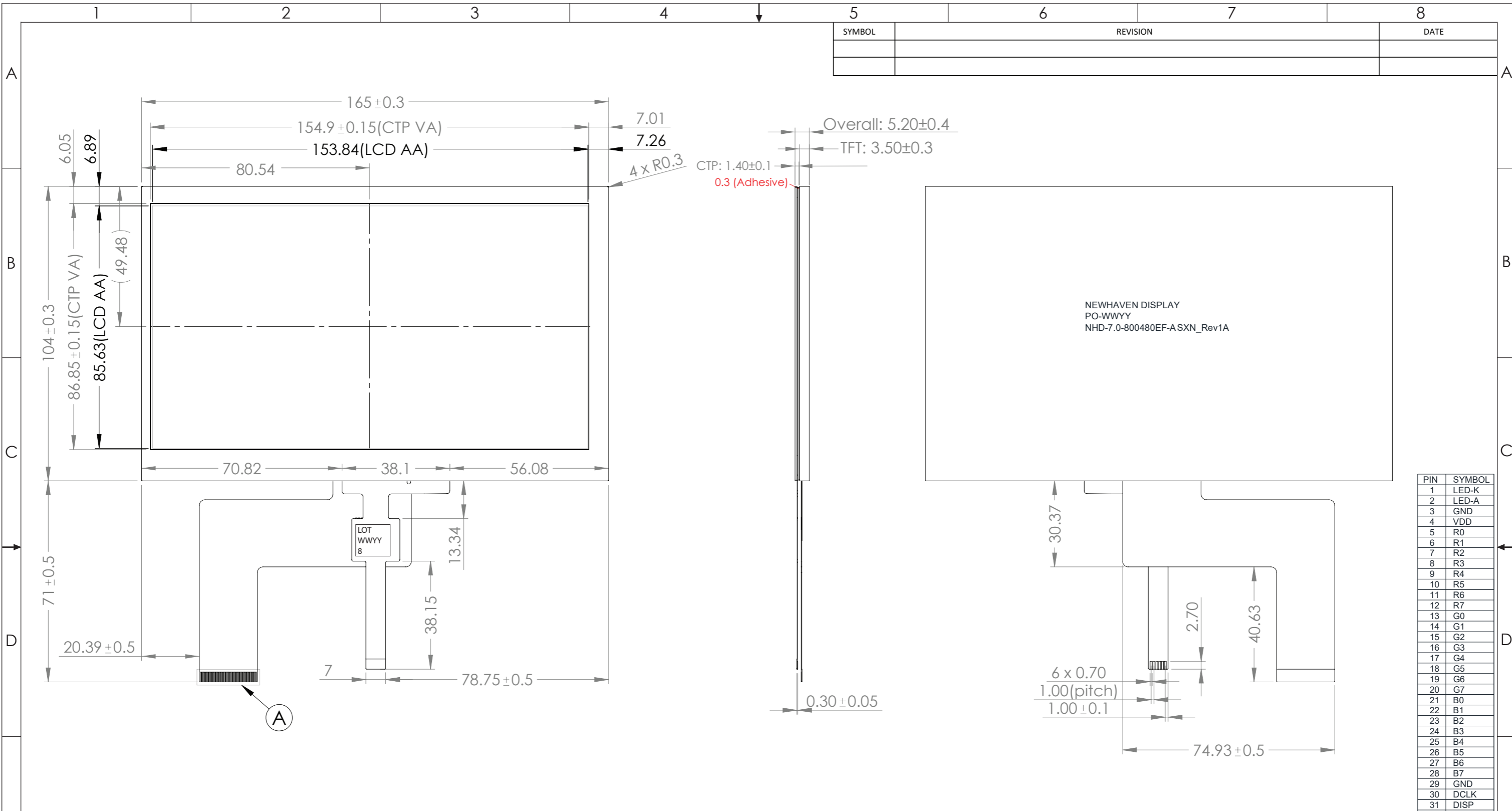

- NOTES:**
1. Display type: 7" TFT/Anti-glare
 2. Viewing direction: 12 O'CLOCK
 3. Display Mode: Transmissive/Normal White / Anti Glare
 4. Driver IC: EK9716
 5. Power Supply Voltage: 3.3V
 6. Backlight: White LED / 9.3V / 180mA (Typ)
 7. Brightness: 820cd/m² (Typ)
 8. 3M Brightness Enhancement Film
 9. Touch Panel: PCAP

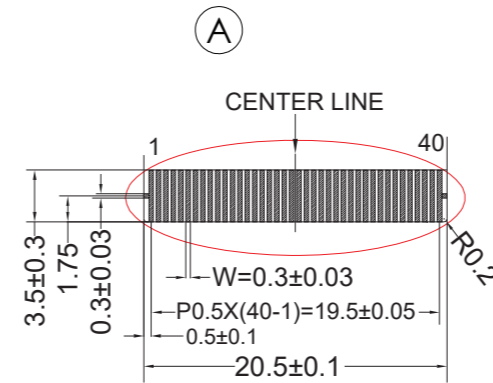
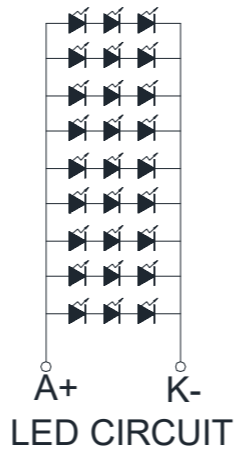

STANDARD TOLERANCE:
(UNLESS OTHERWISE SPECIFIED)

LINEAR: ±0.3mm

UNLESS OTHERWISE SPECIFIED:
- DIMENSIONS ARE IN MILLIMETERS
- THIRD ANGLE PROJECTION

DO NOT SCALE DRAWING

THIS DRAWING IS SOLELY THE PROPERTY OF NEWHAVEN DISPLAY INTERNATIONAL, INC. THE INFORMATION IT CONTAINS IS NOT TO BE DISCLOSED, REPRODUCED OR COPIED IN WHOLE OR PART WITHOUT WRITTEN APPROVAL FROM NEWHAVEN DISPLAY.

NEWHAVEN DISPLAY INTERNATIONAL

DRAWING/PART NUMBER:
NHD-7.0-800480EF-ASXN#-CTP

REVISION:
1A

SIZE:
A3

SCALE:
NS

SHEET 1 OF 1

DRAWN BY: S. Baxi
APPROVED BY: S. Baxi
DRAWN DATE: 3/9/20
APPROVED DATE: 3/9/20

Pin Description

TFT:

Pin No.	Symbol	External Connection	Function Description
1	LED-K	Power Supply	Ground for Backlight
2	LED-A	Power Supply	Backlight Power Supply (180mA @ 9.6V)
3	GND	Power Supply	Ground
4	V _{DD}	Power Supply	Power Supply (3.3V)
5-12	[R0-R7]	MPU	Red Data Signals
13-20	[G0-G7]	MPU	Green Data Signals
21-28	[B0-B7]	MPU	Blue Data Signals
29	GND	Power Supply	Ground
30	DCLK	MPU	Dot data Clock (Falling Edge Triggered)
31	DISP	MPU	Display on/off DISP=1: Display on; DISP=0: Display off
32	HSYNC	MPU	Line synchronization signal
33	VSYNC	MPU	Frame synchronization signal
34	DEN	MPU	Data Enable signal
35	NC	-	No Connect
36	GND	Power Supply	Ground
37	NC(XR)	-	No Connect
38	NC(YD)	-	No Connect
39	NC(XL)	-	No Connect
40	NC(YU)	-	No Connect

LCD connector: 0.5mm pitch 40-Conductor FFC. Molex p/n: 54104-4031 (top contact)

Capacitive Touch Panel:

Pin No.	Symbol	External Connection	Function Description
1	V _{DD}	Power Supply	Power Supply (3.3V)
2	GND	Power Supply	Ground
3	SCL	MPU	Serial I2C Clock (Requires pull-up resistor)
4	SDA	MPU	Serial I2C Data (Requires pull-up resistor)
5	/INT	MPU	Interrupt signal from touch panel module to host
6	/RESET	MPU	Active LOW Reset signal. (Do not tie to V _{DD})

Recommended connector: 1.0mm pitch 6-Conductor FFC. Molex p/n: 52271-0679

Driver/Controller Information

TFT:

Built-in EK9716B Source Driver: https://www.newhavendisplay.com/appnotes/datasheets/LCDs/EK9716B_v1-1.pdf

Built-in EK73002AB2 Gate Driver: <https://www.newhavendisplay.com/appnotes/datasheets/LCDs/EK73002AB2.pdf>

Capacitive Touch Panel:

Built-in FocalTech FT5426 controller.

Please download specification at <http://www.newhavendisplay.com/appnotes/datasheets/touchpanel/FT5x26.pdf>

Electrical Characteristics

TFT:

Item	Symbol	Condition	Min.	Typ.	Max.	Unit
Operating Temperature Range	T _{OP}	Absolute Max	-20	-	+70	°C
Storage Temperature Range	T _{ST}	Absolute Max	-30	-	+80	°C
Supply Voltage	V _{DD}	-	3.0	3.3	3.6	V
Supply Current	I _{DD}	V _{DD} = 3.3V, 25°C	45	90	135	mA
"H" Level Input	V _{IH}	-	0.7*V _{DD}	-	V _{DD}	V
"L" Level Input	V _{IL}	-	V _{SS}	-	0.3*V _{DD}	V
"H" Level Output	V _{OH}	-	V _{DD} -0.4	-	-	V
"L" Level Output	V _{OL}	-	V _{SS}	-	GND+0.4	V
Backlight Supply Current	I _{LED}	-	-	180	225	mA
Backlight Supply Voltage	V _{LED}	I _{LED} = 180mA	8.7	9.3	10.2	V
Backlight Lifetime*	-	T _{OP} = 25° C	20,000	50,000	-	Hrs.

*Backlight lifetime is rated as Hours until **half-brightness**, under normal operating conditions. The LED of the backlight is driven by current drain; drive voltage is for reference only. Drive voltage must be selected to ensure backlight current drain is below MAX level stated.

Capacitive Touch Panel:

Item	Symbol	Condition	Min.	Typ.	Max.	Unit
Operating Temperature Range	T _{OP}	Absolute Max	-20	-	+70	°C
Storage Temperature Range	T _{ST}	Absolute Max	-30	-	+80	°C
Supply Voltage	V _{DD}	-	2.8	3.3	3.6	V
Supply Current – Operating	I _{DD}	V _{DD} = 3.3V T _{OP} = 25°C	-	15.0	-	mA
Supply Current – Hibernate	I _{DD}		-	1.0	-	µA
"H" Level Input	V _{IH}	-	0.7*V _{DD}	-	V _{DD}	V
"L" Level Input	V _{IL}	-	V _{SS}	-	0.3*V _{DD}	V
"H" Level Output	V _{OH}	-	0.7*V _{DD}	-	V _{DD}	V
"L" Level Output	V _{OL}	-	V _{SS}	-	0.3*V _{DD}	V

Optical Characteristics

Item	Symbol	Condition	Min.	Typ.	Max.	Unit	
Optimal Viewing Angles	Top	CR ≥ 10	-	60	-	°	
	Bottom		-	50	-	°	
	Left		-	60	-	°	
	Right		-	60	-	°	
Contrast Ratio	CR	-	-	500	-	-	
Luminance	L _V	I _{LED} = 180 mA	660	820	-	cd/m ²	
Response Time	T _R + T _F	T _{OP} = 25°C	-	25	-	ms	
Chromaticity	Red	X _R	-	0.532	0.582	0.632	-
		Y _R	-	0.292	0.342	0.392	-
	Green	X _G	-	0.285	0.335	0.385	-
		Y _G	-	0.574	0.624	0.674	-
	Blue	X _B	-	0.104	0.154	0.204	-
		Y _B	-	0.092	0.142	0.192	-
White	X _W	-	0.257	0.307	0.357	-	
	Y _W	-	0.334	0.384	0.434	-	

Capacitive Touch Panel Material Characteristics:

Property	Requirement	Unit
IC	FT5426	-
ITO Glass thickness	0.55	mm
Surface Hardness	≥6	H
Light transmission	82%	-
Operating Humidity	20~90	RH
Storage Humidity	20~90	RH

Capacitive Touch Panel Registers

Register No.	Access	Register Name	Bits	Value	Description
01h	RO	Gesture ID	[7:0]	10	Swipe Up
				18h	Swipe Down
				1Ch	Swipe Left
				14h	Swipe Right
				48h	Zoom Out
				49h	Zoom In
				00	No gesture
02h	RO	Touch Points	[7:0]	0-Ah	0: No touch detected A: 10 touch points detected
03h	RO	TOUCH1_Event_Flag	[7:6]	0	Put Down
				1	Put Up
				2	Contact
				3	Reserved
03h	RO	TOUCH1_XH	[3:0]	0 -1	Upper 4 bits of X touch coordinate
04h	RO	TOUCH1_XL	[7:0]	00 - FFh	Lower 8 bits of X touch coordinate
05h	RO	TOUCH1_YH	[3:0]	0 -1	Upper 4 bits of Y touch coordinate
06h	RO	TOUCH1_YL	[7:0]	00 - FFh	Lower 8 bits of Y touch coordinate
07h	RO	TOUCH1_Weight	[7:0]		Touch Weight
08h	RO	TOUCH1_Misc	[3:0]	00-0Fh	Touch Area
09h	RO	TOUCH2_Event_Flag	[7:6]	0	Put Down
				1	Put Up
				2	Contact
				3	Reserved
09h	RO	TOUCH1_XH	[3:0]	0 -1	Upper 4 bits of X touch coordinate
0Ah	RO	TOUCH2_XL	[7:0]	00 - FFh	Lower 8 bits of X touch coordinate
0Bh	RO	TOUCH2_YH	[3:0]	0 -1	Upper 4 bits of Y touch coordinate
0Ch	RO	TOUCH2_YL	[7:0]	00 - FFh	Lower 8 bits of Y touch coordinate
0Dh	RO	TOUCH2_Weight	[7:0]		Touch Weight
0Eh	RO	TOUCH2_Misc	[3:0]	00-0Fh	Touch Area
0Fh	RO	TOUCH3_Event_Flag	[7:6]	0	Put Down
				1	Put Up
				2	Contact
				3	Reserved
0Fh	RO	TOUCH3_XH	[3:0]	0 -1	Upper 4 bits of X touch coordinate
10	RO	TOUCH3_XL	[7:0]	00 - FFh	Lower 8 bits of X touch coordinate
11h	RO	TOUCH3_YH	[3:0]	0 -1	Upper 4 bits of Y touch coordinate
12h	RO	TOUCH3_YL	[7:0]	00 - FFh	Lower 8 bits of Y touch coordinate
13h	RO	TOUCH3_Weight	[7:0]		Touch Weight
14h	RO	TOUCH3_Misc	[3:0]	00-0Fh	Touch Area
15h	RO	TOUCH4_Event_Flag	[7:6]	0	Put Down
				1	Put Up
				2	Contact
				3	Reserved
15h	RO	TOUCH4_XH	[3:0]	0 -1	Upper 4 bits of X touch coordinate
16h	RO	TOUCH4_XL	[7:0]	00 - FFh	Lower 8 bits of X touch coordinate
17h	RO	TOUCH4_YH	[3:0]	0 -1	Upper 4 bits of Y touch coordinate
18h	RO	TOUCH4_YL	[7:0]	00 - FFh	Lower 8 bits of Y touch coordinate
1Ah	RO	TOUCH4_Misc	[3:0]	00-0Fh	Touch Area
1Bh	RO	TOUCH5_Event_Flag	[7:6]	0	Put Down
				1	Put Up
				2	Contact
				3	Reserved

Register No.	Access	Register Name	Bits	Value	Description
1Bh	RO	TOUCH5_XH	[3:0]	0 -1	Upper 4 bits of X touch coordinate
1Ch	RO	TOUCH5_XL	[7:0]	00 - FFh	Lower 8 bits of X touch coordinate
1Dh	RO	TOUCH5_YH	[3:0]	0 -1	Upper 4 bits of Y touch coordinate
1Eh	RO	TOUCH5_YL	[7:0]	00 - FFh	Lower 8 bits of Y touch coordinate
1Fh	RO	TOUCH5_Weight	[7:0]		Touch Weight
20	RO	TOUCH5_Misc	[3:0]	00-0Fh	Touch Area
21h	RO	TOUCH6_Event_Flag	[7:6]	0	Put Down
				1	Put Up
				2	Contact
				3	Reserved
21h	RO	TOUCH6_XH	[3:0]	0 -1	Upper 4 bits of X touch coordinate
22h	RO	TOUCH6_XL	[7:0]	00 - FFh	Lower 8 bits of X touch coordinate
23h	RO	TOUCH6_YH	[3:0]	0 -1	Upper 4 bits of Y touch coordinate
24h	RO	TOUCH6_YL	[7:0]	00 - FFh	Lower 8 bits of Y touch coordinate
25h	RO	TOUCH6_Weight	[7:0]		Touch Weight
26h	RO	TOUCH6_Misc	[3:0]	00-0Fh	Touch Area
27h	RO	TOUCH7_Event_Flag	[7:6]	0	Put Down
				1	Put Up
				2	Contact
				3	Reserved
27h	RO	TOUCH7_XH	[3:0]	0 -1	Upper 4 bits of X touch coordinate
28h	RO	TOUCH7_XL	[7:0]	00 - FFh	Lower 8 bits of X touch coordinate
29h	RO	TOUCH7_YH	[3:0]	0 - 1	Upper 4 bits of Y touch coordinate
2Ah	RO	TOUCH7_YL	[7:0]	00 - FFh	Lower 8 bits of Y touch coordinate
2Bh	RO	TOUCH7_Weight	[7:0]		Touch Weight
2Ch	RO	TOUCH7_Misc	[3:0]	00-0Fh	Touch Area
2Dh	RO	TOUCH8_Event_Flag	[7:6]	0	Put Down
				1	Put Up
				2	Contact
				3	Reserved
2Dh	RO	TOUCH8_XH	[3:0]	0 - 1	Upper 4 bits of X touch coordinate
2Eh	RO	TOUCH8_XL	[7:0]	00 - FFh	Lower 8 bits of X touch coordinate
2Fh	RO	TOUCH8_YH	[3:0]	0 - 1	Upper 4 bits of Y touch coordinate
30	RO	TOUCH8_YL	[7:0]	00 - FFh	Lower 8 bits of Y touch coordinate
31h	RO	TOUCH8_Weight	[7:0]		Touch Weight
32h	RO	TOUCH8_Misc	[3:0]	00-0Fh	Touch Area
33h	RO	TOUCH9_Event_Flag	[7:6]	0	Put Down
				1	Put Up
				2	Contact
				3	Reserved
33h	RO	TOUCH9_XH	[3:0]	0 - 1	Upper 4 bits of X touch coordinate
34h	RO	TOUCH9_XL	[7:0]	00 - FFh	Lower 8 bits of X touch coordinate
35h	RO	TOUCH9_YH	[3:0]	0 - 1	Upper 4 bits of Y touch coordinate
36h	RO	TOUCH9_YL	[7:0]	00 - FFh	Lower 8 bits of Y touch coordinate
37h	RO	TOUCH9_Weight	[7:0]		Touch Weight
38h	RO	TOUCH9_Misc	[3:0]	00 - 0Fh	Touch Area
39h	RO	TOUCH10_Event_Flag	[7:6]	0	Put Down
				1	Put Up
				2	Contact
				3	Reserved
39h	RO	TOUCH10_XH	[3:0]	0 - 1	Upper 4 bits of X touch coordinate
3Ah	RO	TOUCH10_XL	[7:0]	00 - FFh	Lower 8 bits of X touch coordinate
3Bh	RO	TOUCH10_YH	[3:0]	0 - 1	Upper 4 bits of Y touch coordinate
3Ch	RO	TOUCH10_YL	[7:0]	00 - FFh	Lower 8 bits of Y touch coordinate

Register No.	Access	Register Name	Bits	Value	Description
3Dh	RO	TOUCH10_Weight	[7:0]	00-FFh	Touch Weight
3Eh	RO	TOUCH10_Misc	[3:0]	00-0Fh	Touch Area
80	RW	ID_G_MC_THGROUP	[7:0]	00-FFh	Mutual-Capacitive touch Threshold / 4 Default: 4Bh
81h	RW	ID_G_MC_THPEAK	[7:0]	00-FFh	Mutual-Capacitive Peak Threshold / 4 Default: 46h
85h	RW	ID_G_THDIFF	[7:0]	00-FFh	Points Filtering Range Threshold / 16 Default: A0
86h	RW	ID_G_CTRL	[1:0]	0-1	Allowed to switch to monitor mode or not (1: Allowed, 0: Not Allowed)
88h	RW	ID_G_PERIODACTIVE	[3:0]	3h-Eh	Period of Active Status
89h	RW	ID_G_PERIODMONITOR	[7:0]	1Eh-FFh	Timer to enter "idle" while in Monitor (ms)
A1h	RO	ID_G_LIB_VERSION_H	[7:0]	00-FFh	App library version high-byte Default: 0
A2h	RO	ID_G_LIB_VERSION_L	[7:0]	00-FFh	App library version low-byte Default: 2h
A3h	RO	ID_G_CHIPER_HIGH	[7:0]	00-FFh	Chip Vendor ID Default: 0x54
A4h	RW	ID_G_MODE	[0]	0 1	INT Trigger Mode INT Polling Mode
A5h	RW	ID_G_PMODE	[1:0]	0 1 3	Active Monitor Sleep
A6h	RO	ID_G_FIRMID	[7:0]	00-FFh	Firmware ID Number Default: 8
A8h	RO	ID_G_VENODRID	[7:0]	00-FFh	CTPM Vendor's Chip ID Default: 79h
C0h	RW	ID_G_GLOVE_MODE_EN	[0]	0 1	Glove Mode Switch Disable Glove Mode Switch Enable
C1h	RW	ID_G_COVER_MODE_EN	[0]	0 1	Cover Mode Switch Disable Cover Mode Switch Enable

Timing Characteristics

Parallel RGB Input Timing Requirements

Item	Symbol	Min.	Typ.	Max.	Unit	Remark	
DCLK Frequency	F_{clk}	28.2	29.2	40	MHz	-	
DLCK Period	T_{clk}	25	34	-	ns	-	
HSYNC	Period Time	T_h	908	928	1088	DCLK	Thw + Thbp = 88 DCLK is fixed
	Display Period	T_{ndisp}	800			DCLK	
	Pulse Width	T_{hw}	1	48	87	DCLK	
	Back Porch	T_{hbp}	87	40	1	DCLK	
	Front Porch	T_{hfp}	20	40	200	DCLK	
VSYNC	Display Period	T_{vdisp}	480			H	Tv + Tvbp = 32 H is fixed
	Period Time	T_v	517	525	613	H	
	Pulse Width	T_{vw}	1	1	3	H	
	Back Porch	T_{vbp}	31	31	29	H	
	Front Porch	T_{vfp}	5	13	101	H	

DE Mode Timing Diagram

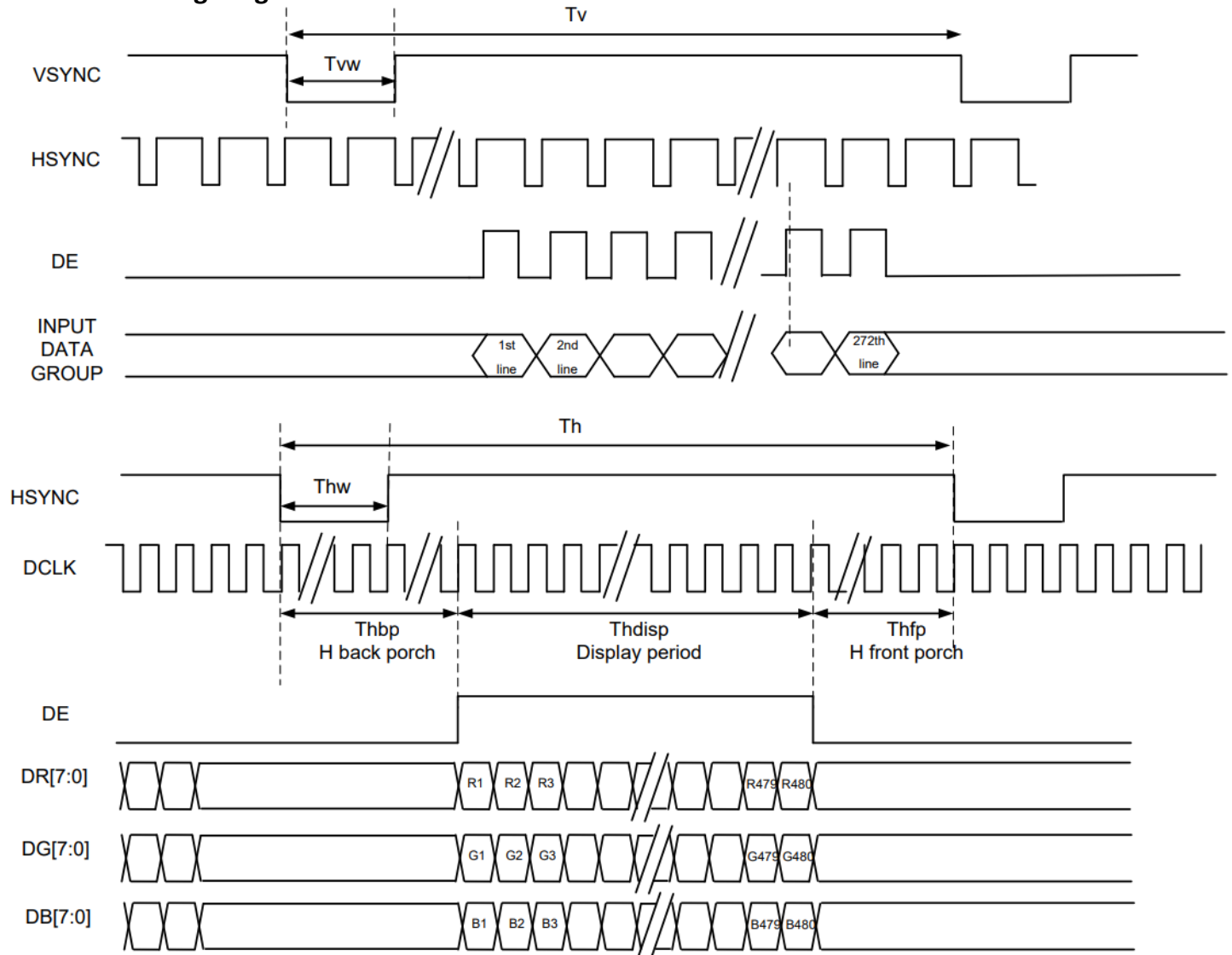

Input Setup Timing Requirements

Item	Symbol	Min.	Typ.	Max.	Unit	Conditions
V _{DD} Power Source Slew Time	T _{por}	-	-	20	ms	From 0V to 90% V _{DD}
CLK cycle time	T _{cph}	20	-	-	ns	-
CLK pulse duty	T _{cwh}	40	50	60	%	-
Data setup time	T _{dsu}	8	-	-	ns	-
Data hold time	T _{dhd}	8	-	-	ns	-
DEN setup time	T _{esu}	8	-	-	ns	-
DEN hold time	T _{ehd}	8	-	-	ns	-

Input Setup Timing Diagram

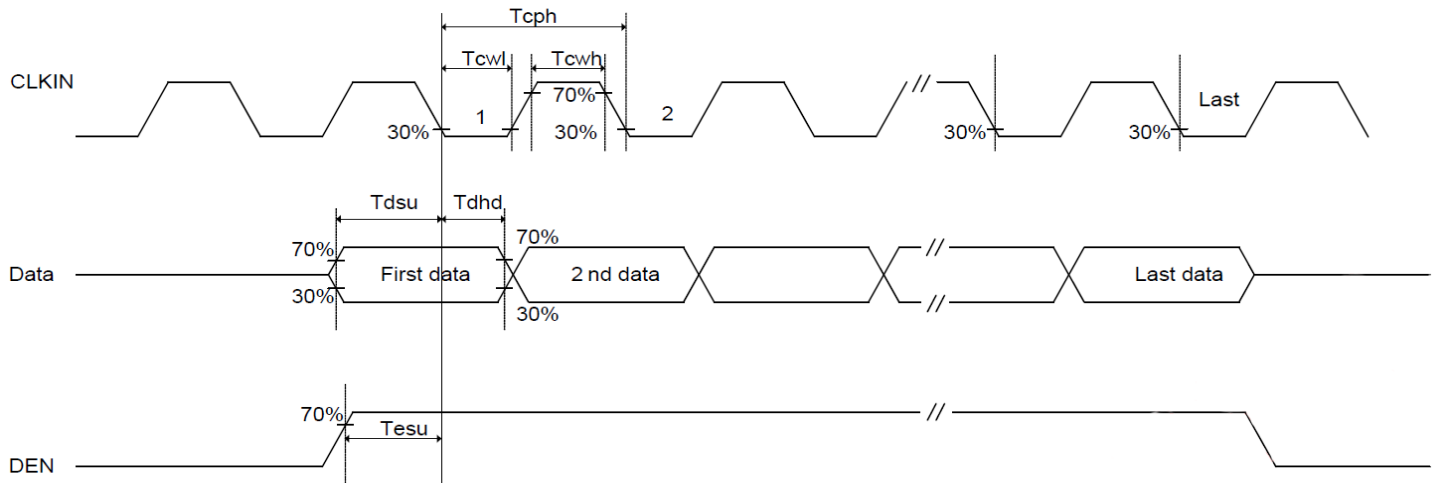

Power ON/OFF Sequence

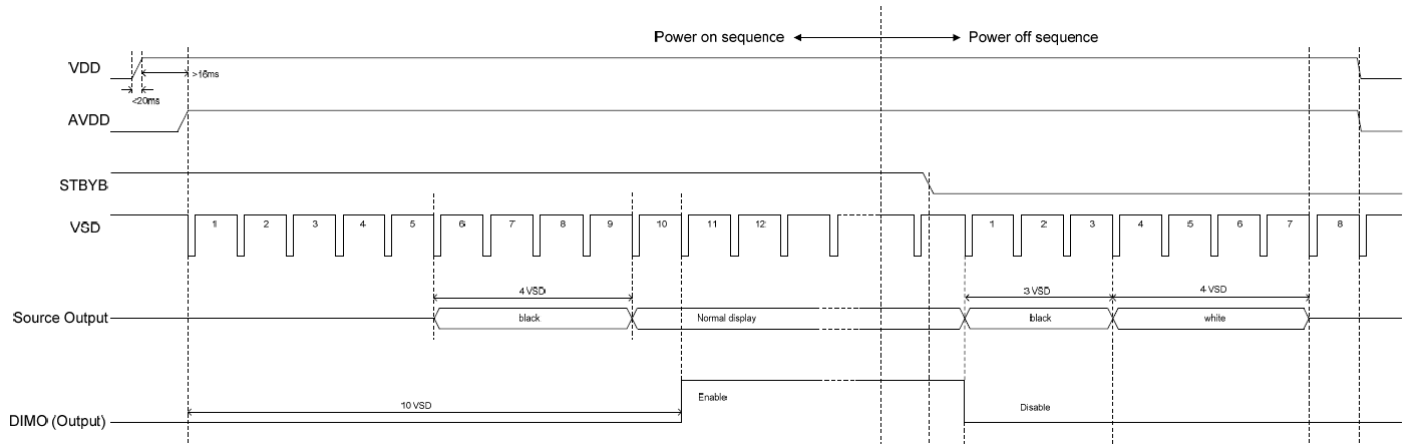

Enter/Exit Standby Mode Sequence

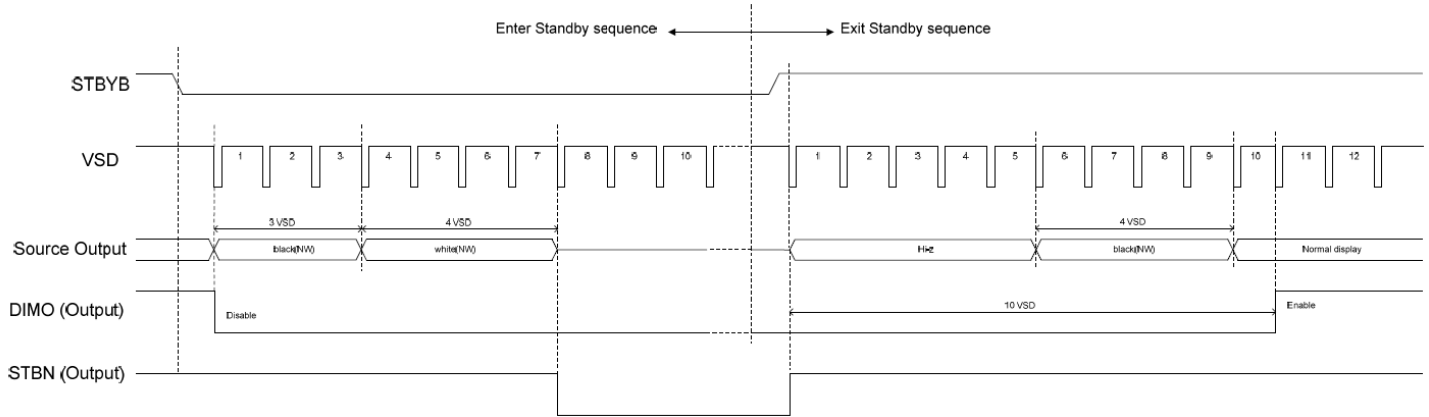

Timing Characteristics – Capacitive Touch Panel

Data Transfer Format

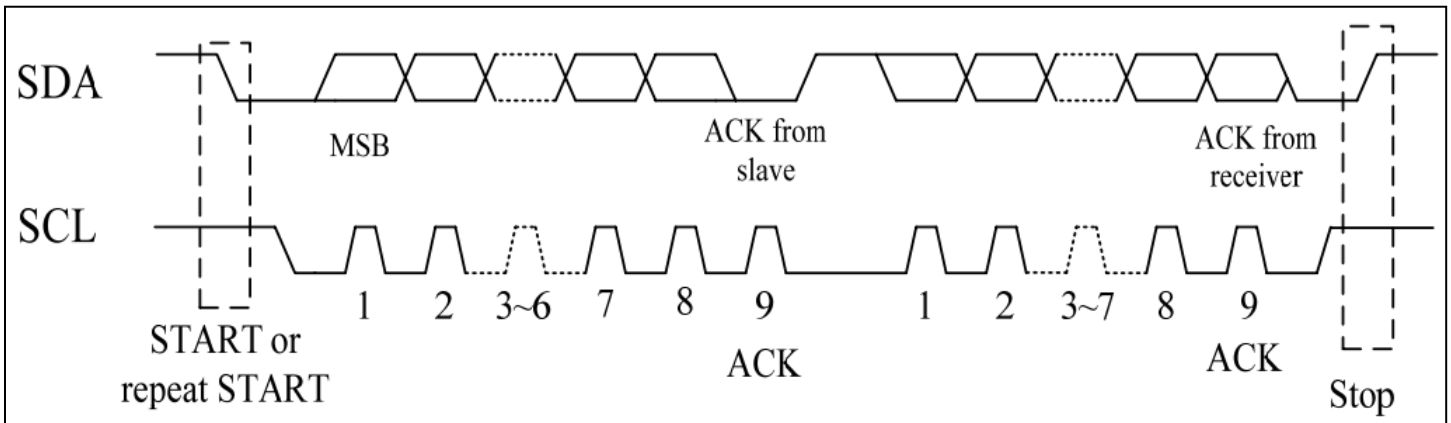

Parameter	Min	Max	Unit
SCL Frequency	0	400	KHz
Bus free time between a STOP & START condition	1.3	-	μ s
Hold time Repeated START condition	0.6	-	μ s
Data Setup Time	100	-	ns
Setup time for a repeated START condition	0.6	-	μ s
Setup time for a STOP condition	0.6	-	μ s

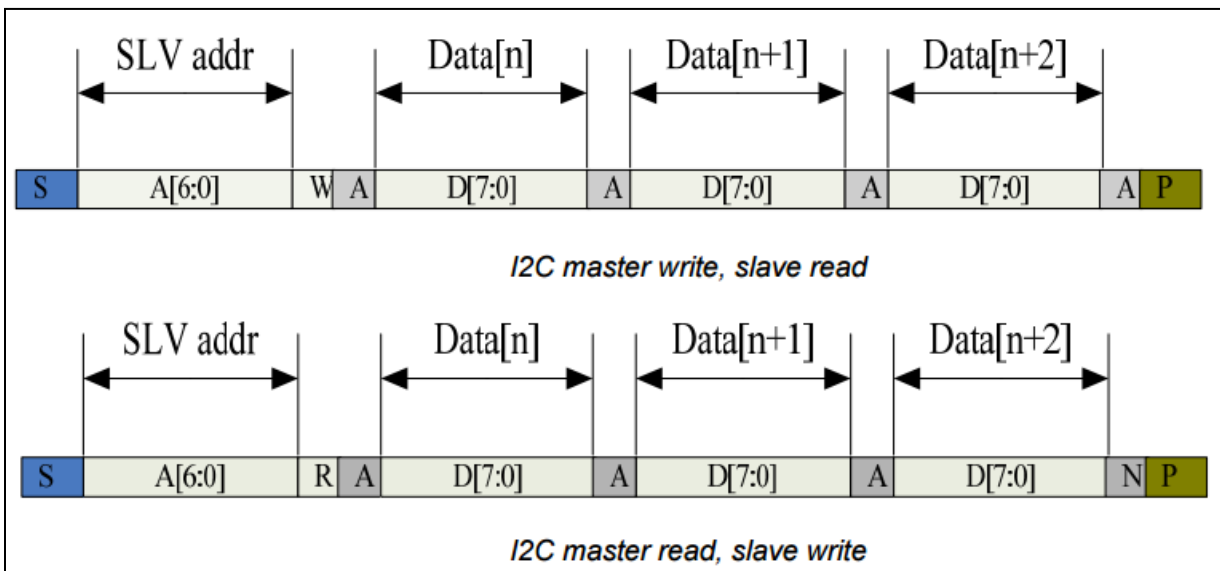

Power ON/Reset Sequence

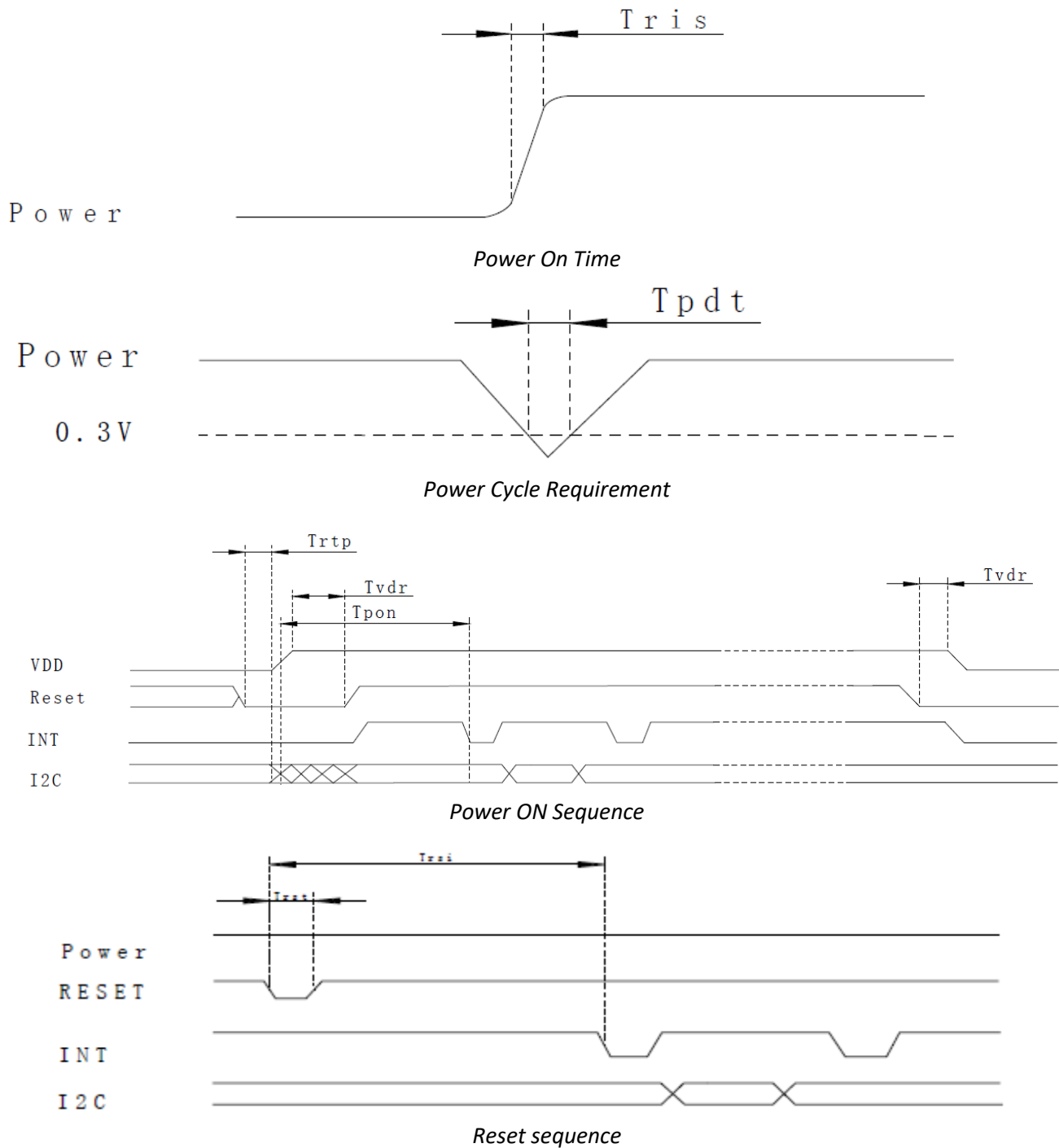

Parameter	Description	Min	Max	Unit
T_{ris}	Rise time from $0.1V_{DD}$ to $0.9V_{DD}$	-	5	ms
$T_{pd\ t}$	Time of the voltage of supply being below 0.3V	5	-	ms
T_{rtp}	Time of resetting to be low before powering on	100	-	μs
T_{pon}	Time to start reporting after power on	-	200	ms
T_{vdr}^*	Reset time after applying V_{DD}	1	-	ms
T_{rsi}	Time to start reporting after reset	-	200	ms
T_{rst}^*	Reset Time	1	-	ms

*Note: If Reset is tied to V_{DD} data corruption can occur

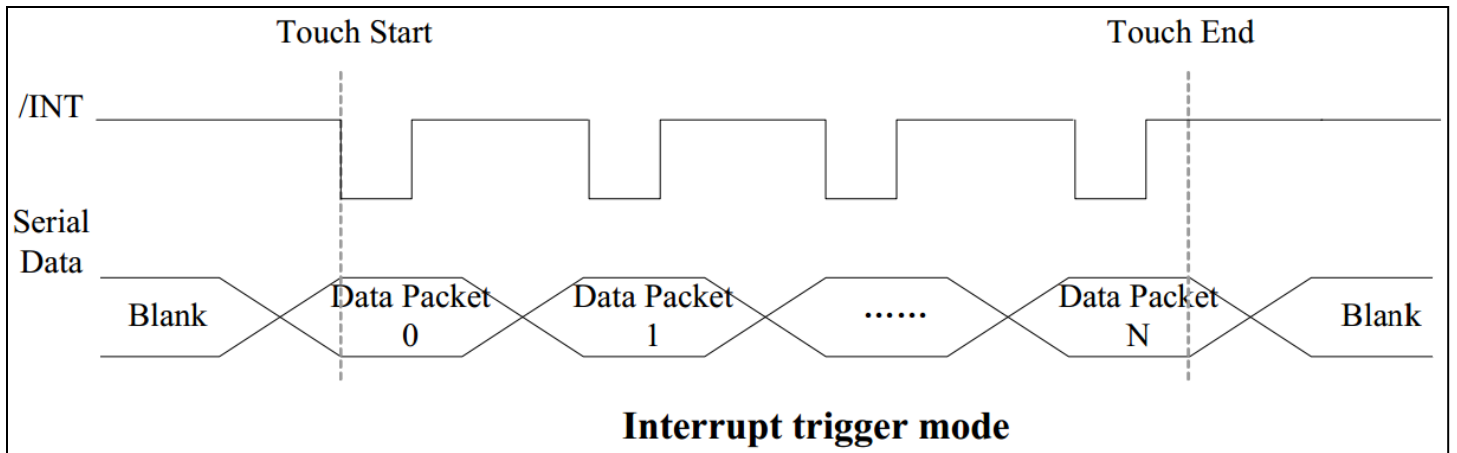

Sample code to read touch data:

```

i2c_start();
i2c_tx(0x70);           //Slave Address (Write)
i2c_tx(0x00);           //Start reading address
i2c_stop();

i2c_start();
i2c_tx(0x71);           //Slave Address (Read)
for(i=0x00;i<0x1F;i++)
{touchdata_buffer[i] = i2c_rx(1);}
i2c_stop();

```

Sample code to overwrite default register values:

```

i2c_start();
i2c_tx(0x70);           //Slave Address (Write)
i2c_tx(0xA4);           //ID_G_Mode
i2c_tx(0x01);           //Disable interrupt status to host
i2c_stop();

```

Quality Information

Test Item	Content of Test	Test Condition	Note
High Temperature storage	Endurance test applying the high storage temperature for a long time.	+80°C, 96hrs	2
Low Temperature storage	Endurance test applying the low storage temperature for a long time.	-30°C, 96hrs	1,2
High Temperature Operation	Endurance test applying the electric stress (voltage & current) and the high thermal stress for a long time.	+70°C, 96hrs	2
Low Temperature Operation	Endurance test applying the electric stress (voltage & current) and the low thermal stress for a long time.	-20°C, 96hrs	1,2
High Temperature / Humidity Operation	Endurance test applying the electric stress (voltage & current) and the high thermal with high humidity stress for a long time.	+50°C, 90% RH, 96hrs	1,2
Thermal Shock resistance	Endurance test applying the electric stress (voltage & current) during a cycle of low and high thermal stress.	-30°C, 30min -> 80°C, 30min, Change time 5min, 10 cycles	
Vibration test	Endurance test applying vibration to simulate transportation and use.	10-55Hz, 1.5mm amplitude. 60 sec in each of 3 directions: X, Y, Z For 15 minutes	3
Static electricity test	Endurance test applying electric static discharge.	Air: ±8KV 150pf/330Ω 5 Times	
		Contact: ±4KV 150pf/330Ω 5 times	

Note 1: No condensation to be observed.

Note 2: Conducted after 4 hours of storage at 25°C, 0%RH.

Note 3: Test performed on product itself, not inside a container.

Precautions for using LCDs/LCMs

See Precautions at www.newhavendisplay.com/specs/precautions.pdf

Warranty Information and Terms & Conditions

http://www.newhavendisplay.com/index.php?main_page=terms