

THIS DOCUMENT IS THE PROPERTY OF  
KEYSTONE ELECTRONICS CORP. AND  
SHALL NOT BE REPRODUCED, DISTRIBUTED  
OR USED AS A BASIS FOR MANUFACTURE  
WITHOUT PRIOR WRITTEN PERMISSION  
FROM KEYSTONE ELECTRONICS CORP.

ACTUAL SIZE

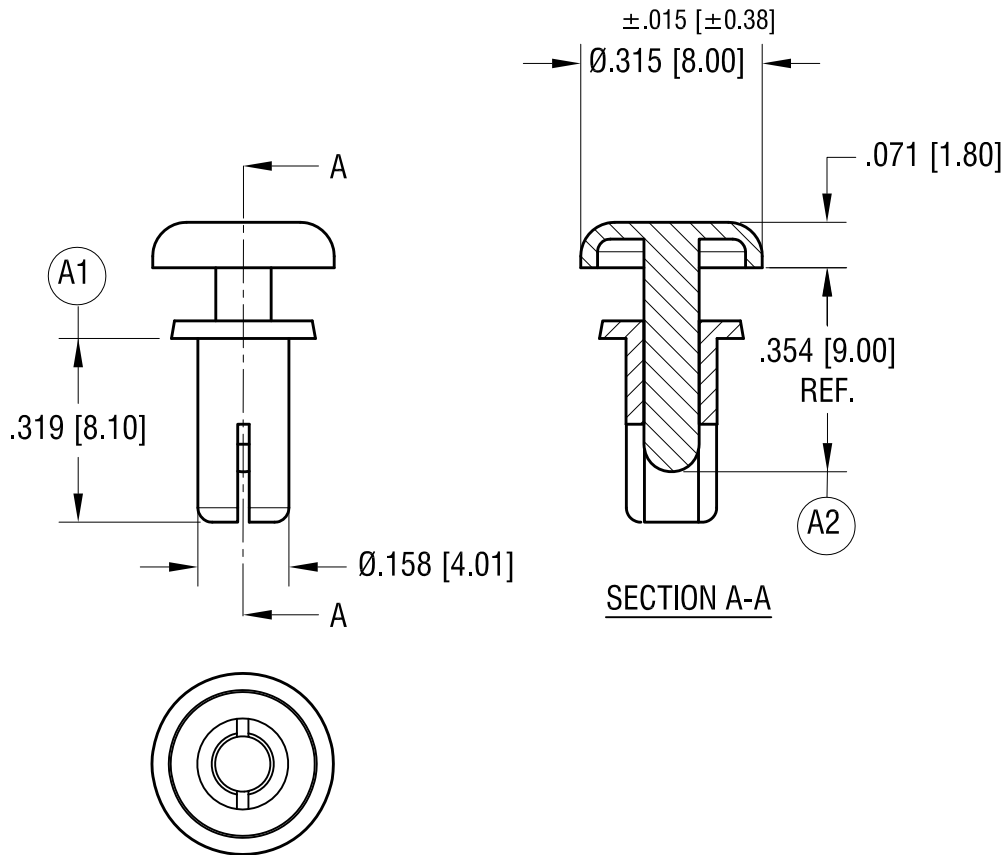
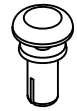

NOTES:

1. RECOMMENDED MOUNTING HOLE:  
.163 [4.14] DIA.
2. CHASSIS THICKNESS:  
.217 [5.50] TO .256 [6.50]

(A1) WAS .310, (A2) WAS .350

8.27.21 CHANGE AS PER ECN 21-099

DATE DESCRIPTION

A  
REV.

<b>KEYSTONE ELECTRONICS CORP.</b>			
www.keyelco.com • NEW HYDE PARK, NY 11040 • Tel (516) 328-7500			
PART NAME		SNAP RIVET	
MATERIAL			
NYLON 6/6 UL 94V-2 (BLACK COLOR)			
FINISH		DRN BY	DATE
NONE		BOONE	9.29.06
		APP'D	SCALE
		RH	3X
TOLERANCES	INCH [MM]	CODE	DWG NO.
DECIMAL	$\pm .010 [\pm 0.25]$	C	3448
ANGULAR	$\pm 1^\circ$		
UNLESS OTHERWISE SPECIFIED			