

Introduction

The Infresco-T 4kW is part of a family of controllers designed to provide energy saving when used with Quartz Infrared Halogen Lamps or other Heating and Lighting Products. The 'T' model switches the lamps on for a pre-determined time period of between 1 and 40 minutes. The microcontroller-based unit incorporates zero-voltage switching and a soft-start function to eliminate the lamps' initial high inrush current – potentially increasing lamp life by as much as 30%. Installation of the unit is simple and once installed is relatively maintenance-free.

Product Features

- Energy saving – provides heat for a pre-determined time period.
- Extends Lamp Life.
- Soft-start/zero-voltage switch-off.
- Low-cost.
- Easy to install.

Applications: patio areas, smoking shelters, restaurants, warehouses, workshops and garden lighting.

Installation

Important: Read carefully the following information before installing the unit.

The Infresco-T 4kW should be fixed securely using the four mounting holes accessible from the front of the unit. Remove the lid to access the mounting holes. To ease installation, a mounting template is provided on the next page to locate the 4 mounting hole centres.

IMPORTANT! The unit must be orientated with the cable glands facing down.

Wiring

It is recommended that installation and maintenance of this equipment should be done with reference to the current edition of the I.E.E. wiring regulations (BS7671) by suitably qualified/trained personnel. These regulations contain important requirements regarding safety of electrical equipment (for International Standards refer to I.E.C/ directive IEC950).

Warning! Isolate the mains supply before commencing any work on this unit. Ensure all earth wires are connected to maintain earth continuity to the lamp fittings.

The unit is fitted with two cable glands. Only one cable should be fitted per gland to prevent degrading the unit's IP rating. When fitting two lamps, refer to 'Wiring Diagram' for an alternative wiring configuration using a junction box.

The mains supply connects to the terminal block marked 'LINE'. Connect the supply **LIVE** to the 'L' terminal, **NEUTRAL** to the 'N' terminal and **EARTH** to the 'E' terminal.

The lamps connect to the terminal block marked 'LOAD'. Connect the load **LIVE** to the 'L' terminal, **NEUTRAL** to the 'N' terminal and **EARTH** to the 'E' terminal. If two lamps are to be fitted they must be wired in parallel.

Check all wiring and make sure the cable glands are tightened.

Mounting Template

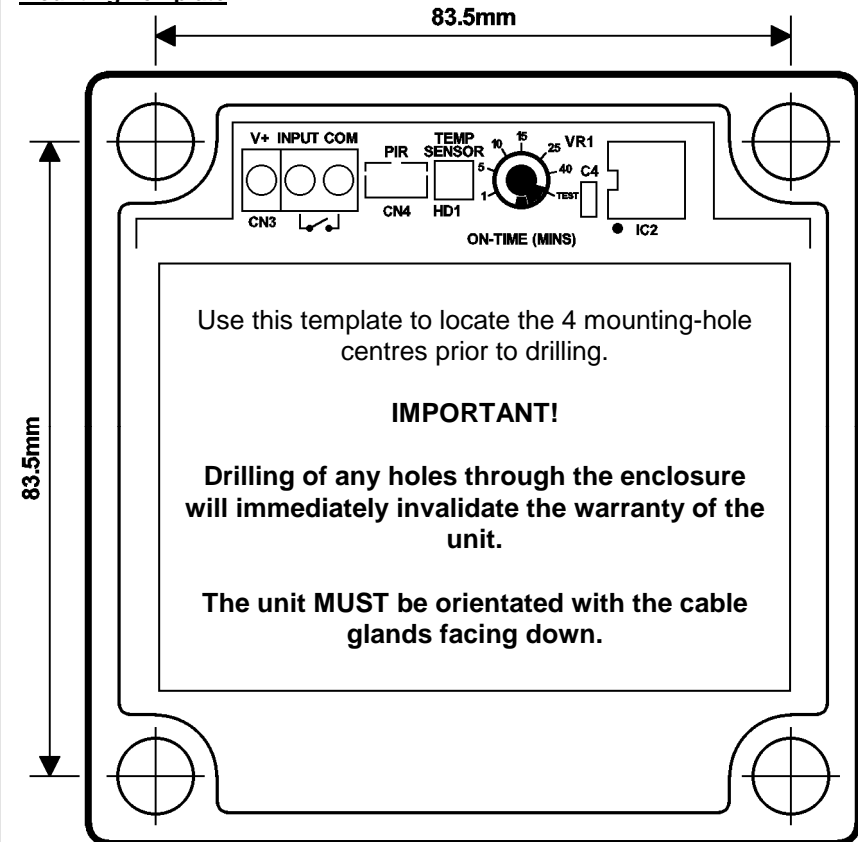

Commissioning

Set the on-time preset (VR1) to a time period of between 1 and 40 minutes. VR1 is located at the top of the printed circuit board as shown above. Replace the lid and switch on the mains supply to the unit. Press the push-button on the front of the unit to switch the lamps on.

Technical Specification

Supply Voltage	230VAC +/- 10% 50 Hz
Switching Capacity	4kW Max.
Lamp On-Time	1 to 40 minutes
Current Consumption (control circuit)	50mA
Terminals	2.5mm ² Rising Clamp
Operating Temperature	-20 to 40°C
Protection Rating	IP65
Gland Diameter	Max Cable Entry 2.5mm ²
Enclosure Dimensions (WxLxH)	100x100x60 (mm)

Wiring Diagram

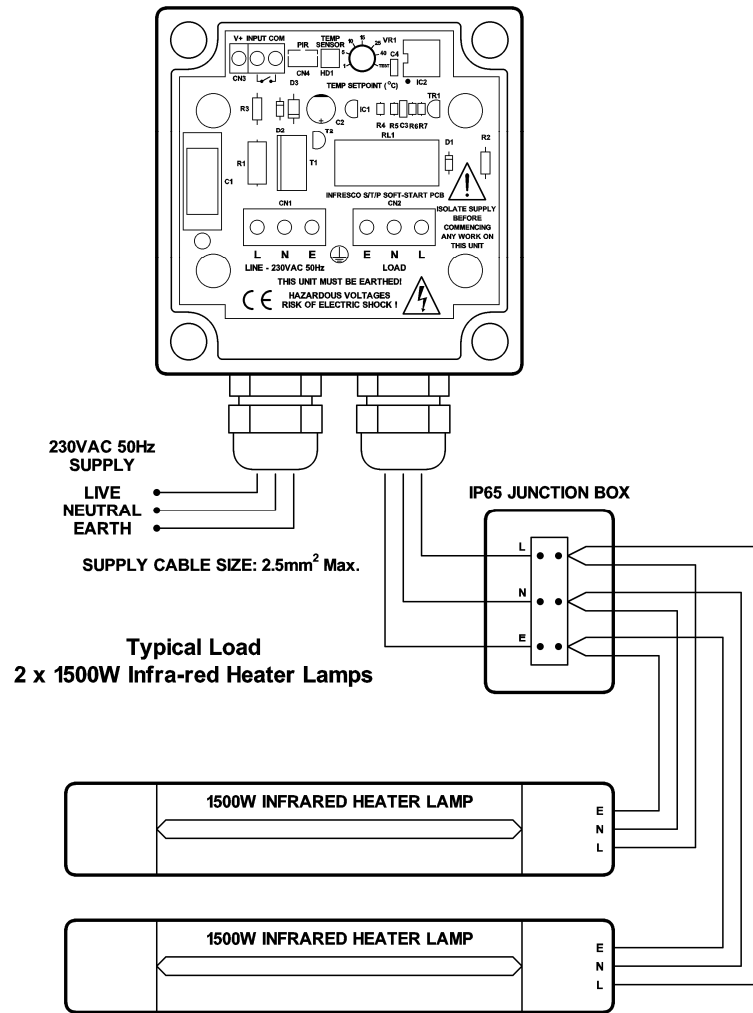

UNITED AUTOMATION LIMITED

1 Southport Business Park
Kew
Southport, PR8 4HQ
ENGLAND

Tel: 0044 (0) 1704 – 516500 Main
Tel: 0044 (0) 1704 - 516516 Sales
Fax: 0044 (0) 1704 – 516501
Enquiry@united-automation.com

INFRESCO-T™

Users & Installation Manual For Infresco T 4kW



**RoHS Compliant
Directive
2002/95/EC**

X20019 Issue 2 22/01/09

