

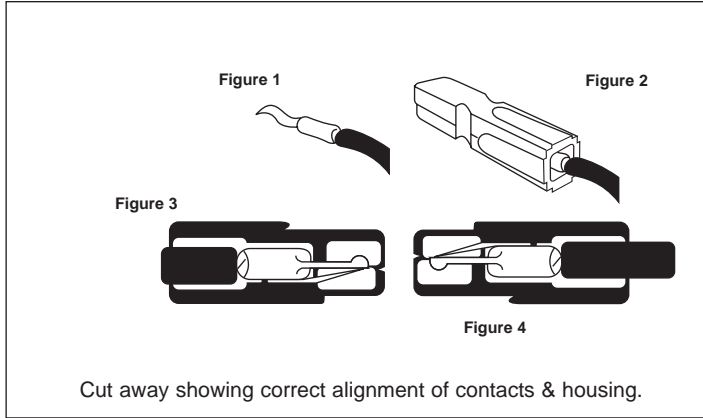

75Amp Modular Multipole Connectors

RS stock nos. 290-6152 and 290-6168

1. Terminate crimp contact (RS stock no. 290-6118) using die set (RS stock no. 290-5941) and hydraulic crimp tool (RS stock no. 445-885).
2. Position crimp contact (see Figure 1) and insert in rear of housing.
3. Push contact forward (see Figure 2).
4. Position front end of contact so that it slips under the barrier and snaps over the end of the retaining spring (see Figure 3). Listen for the 'SNAP'.



The information provided in RS technical literature is believed to be accurate and reliable; however, RS Components assumes no responsibility for inaccuracies or omissions, or for the use of this information, and all use of such information shall be entirely at the user's own risk. No responsibility is assumed by RS Components for any infringements of patents or other rights of third parties which may result from its use. Specifications shown in RS Components technical literature are subject to change without notice.



75Amp Modular Multipole Connectors

RS stock nos. 290-6152 and 290-6168

1. Terminate crimp contact (RS stock no. 290-6118) using die set (RS stock no. 290-5941) and hydraulic crimp tool (RS stock no. 445-885).
2. Position crimp contact (see Figure 1) and insert in rear of housing.
3. Push contact forward (see Figure 2).
4. Position front end of contact so that it slips under the barrier and snaps over the end of the retaining spring (see Figure 3). Listen for the 'SNAP'.

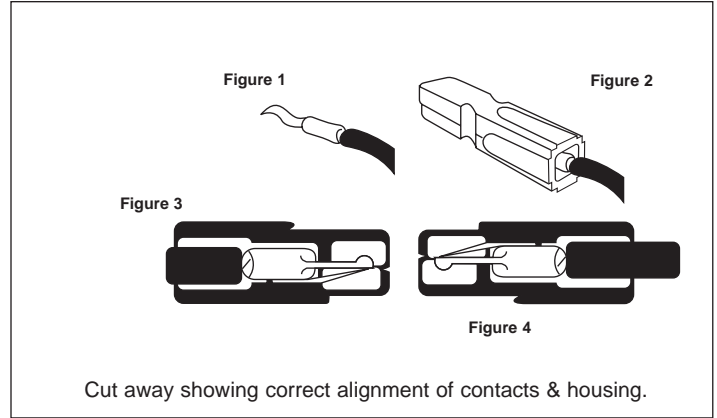

The information provided in RS technical literature is believed to be accurate and reliable; however, RS Components assumes no responsibility for inaccuracies or omissions, or for the use of this information, and all use of such information shall be entirely at the user's own risk. No responsibility is assumed by RS Components for any infringements of patents or other rights of third parties which may result from its use. Specifications shown in RS Components technical literature are subject to change without notice.



75Amp Modular Multipole Connectors

RS stock nos. 290-6152 and 290-6168

1. Terminate crimp contact (RS stock no. 290-6118) using die set (RS stock no. 290-5941) and hydraulic crimp tool (RS stock no. 445-885).
2. Position crimp contact (see Figure 1) and insert in rear of housing.
3. Push contact forward (see Figure 2).
4. Position front end of contact so that it slips under the barrier and snaps over the end of the retaining spring (see Figure 3). Listen for the 'SNAP'.

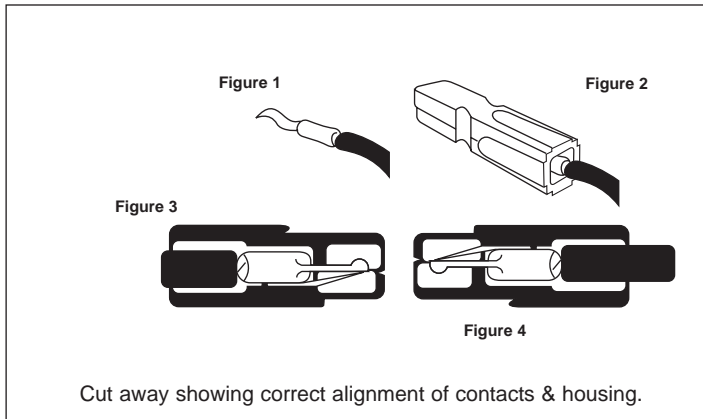

The information provided in RS technical literature is believed to be accurate and reliable; however, RS Components assumes no responsibility for inaccuracies or omissions, or for the use of this information, and all use of such information shall be entirely at the user's own risk. No responsibility is assumed by RS Components for any infringements of patents or other rights of third parties which may result from its use. Specifications shown in RS Components technical literature are subject to change without notice.



75Amp Modular Multipole Connectors

RS stock nos. 290-6152 and 290-6168

1. Terminate crimp contact (RS stock no. 290-6118) using die set (RS stock no. 290-5941) and hydraulic crimp tool (RS stock no. 445-885).
2. Position crimp contact (see Figure 1) and insert in rear of housing.
3. Push contact forward (see Figure 2).
4. Position front end of contact so that it slips under the barrier and snaps over the end of the retaining spring (see Figure 3). Listen for the 'SNAP'.

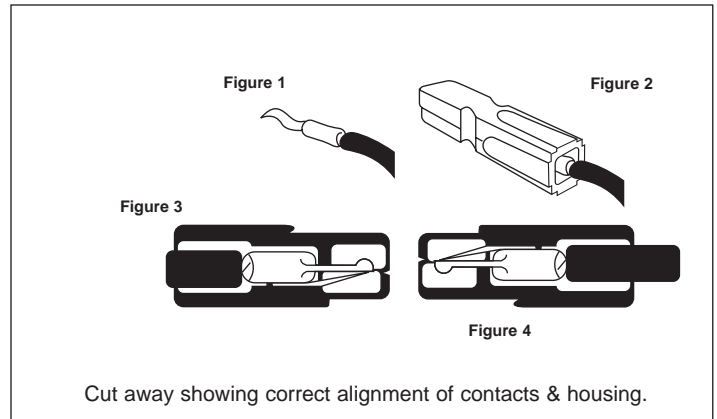

The information provided in RS technical literature is believed to be accurate and reliable; however, RS Components assumes no responsibility for inaccuracies or omissions, or for the use of this information, and all use of such information shall be entirely at the user's own risk. No responsibility is assumed by RS Components for any infringements of patents or other rights of third parties which may result from its use. Specifications shown in RS Components technical literature are subject to change without notice.