

LUXEON 7070

High light output and efficacy in a robust multi-die package, enabling cost-effective system designs for demanding applications

LUXEON 7070 is a multi-die, high power package that provides high luminance from a super robust package to enable cost effective, single optic and directional fixture designs. LUXEON 7070 uses an industry standard 7070 surface mount package with a small Light Emitting Surface (LES). LUXEON 7070 is offered in 70, 80, 90 CRI with a wide range of CCTs, and offers hot-color targeting to ensure that the LEDs are within color target at application conditions of 85°C.



FEATURES AND BENEFITS

- Superior lm/W enables outstanding efficacy in end application
- Extremely reliable package design affirms long lifetime in harsh environments
- Low Rth enables effective thermal dissipation design for higher efficiency
- Hot-color targeting ensures color is within ANSI bin at 85°C
- 3-step and 5-step MacAdam ellipse binning structure ensures excellent color uniformity

PRIMARY APPLICATIONS

- High Bay
- Low Bay
- Floodlights
- Wall Pack
- Outdoor
- Spotlights

Table of Contents

General Product Information	2
Product Test Conditions	2
Part Number Nomenclature	2
Lumen Maintenance	2
Environmental Compliance	2
Performance Characteristics	3
Product Selection Guide	3
Optical Characteristics	3
Electrical and Thermal Characteristics	4
Absolute Maximum Ratings	4
Characteristic Curves	5
Spectral Power Distribution Characteristics	5
Light Output Characteristics	6
Forward Current Characteristics	9
Radiation Pattern Characteristics	11
Product Bin and Labeling Definitions	12
Decoding Product Bin Labeling	12
Luminous Flux Bins	12
Color Bin Definitions	13
Forward Voltage Bins	14
Mechanical Dimensions	15
Reflow Soldering Guidelines	16
JEDEC Moisture Sensitivity	16
Solder Pad Design	17
Packaging Information	18
Pocket Tape Dimensions	18
Reel Dimensions	19

General Product Information

Product Test Conditions

LUXEON 7070 LEDs are tested and binned with at 700mA at a junction temperature, T_j of 25°C.

Part Number Nomenclature

Part numbers for LUXEON 7070 follow the convention below:

L 1 7 0 – **A A B B** 7 0 **C C** 0 0 0 0 0

Where:

- A A** – designates nominal ANSI CCT (22=2200K, 27=2700K, 30=3000K, 35=3500K, 40=4000K, 50=5000K, 57=5700K, 65=6500K)
- B B** – designates minimum CRI (70=70CRI, 80=80CRI, 90=90CRI)
- C C** – designates forward voltage (12 = 12V)

Therefore, the following part number is used for a LUXEON 7070, 4000K 70CRI, 12V:

L 1 7 0 – **4 0 7 0** 7 0 **1 2** 0 0 0 0 0

Lumen Maintenance

Please contact your local Sales Representative or Lumileds Technical Solutions Manager for more information about the long-term performance of this product.

Environmental Compliance

Lumileds LLC is committed to providing environmentally friendly products to the solid-state lighting market. LUXEON 7070 is compliant to the European Union directives on the restriction of hazardous substances in electronic equipment, namely the RoHS Directive 2011/65/EU and REACH Regulation (EC) 1907/2006. Lumileds LLC will not intentionally add the following restricted materials to its products: lead, mercury, cadmium, hexavalent chromium, polybrominated biphenyls (PBB) or polybrominated diphenyl ethers (PBDE).

Performance Characteristics

Product Selection Guide

Table 1. Product performance of LUXEON 7070 at test current, $T_j=25^\circ\text{C}$ and $T_j=85^\circ\text{C}$ for R9 and CRI.

VOLTAGE	NOMINAL CCT ^[1]	MINIMUM R9 ^[4]	MINIMUM CRI ^[2, 3]	LUMINOUS FLUX ^[2, 3] (lm)		TYPICAL LUMINOUS EFFICACY (lm/W)	TEST CURRENT (mA)	PART NUMBER
				MINIMUM	TYPICAL			
12V	2200K	≥ -40	70	1172	1260	153	700	L170-2270701200000
	2700K	≥ -40	70	1295	1392	169	700	L170-2280701200000
	3000K	≥ -40	70	1344	1445	175	700	L170-3070701200000
	3500K	≥ -40	70	1376	1480	179	700	L170-3570701200000
	4000K	≥ -40	70	1414	1520	184	700	L170-4070701200000
	5000K	≥ -40	70	1404	1510	183	700	L170-5070701200000
	5700K	≥ -40	70	1395	1500	182	700	L170-5770701200000
	6500K	≥ -40	70	1386	1490	180	700	L170-6570701200000
	2200K	≥ 0	80	1059	1139	138	700	L170-2280701200000
	2700K	≥ 0	80	1176	1265	153	700	L170-2780701200000
	3000K	≥ 0	80	1232	1325	160	700	L170-3080701200000
	3500K	≥ 0	80	1257	1352	164	700	L170-3580701200000
	4000K	≥ 0	80	1293	1390	168	700	L170-4080701200000
	5000K	≥ 0	80	1288	1385	168	700	L170-5080701200000
	5700K	≥ 0	80	1288	1385	168	700	L170-5780701200000
	6500K	≥ 0	80	1283	1380	167	700	L170-6580701200000
	2200K	≥ 50	90	911	980	119	700	L170-2290701200000
	2700K	≥ 50	90	1018	1095	133	700	L170-2790701200000
	3000K	≥ 50	90	1049	1128	137	700	L170-3090701200000
	3500K	≥ 50	90	1075	1156	140	700	L170-3590701200000
	4000K	≥ 50	90	1102	1185	143	700	L170-4090701200000
	5000K	≥ 50	90	1097	1180	143	700	L170-5090701200000
	5700K	≥ 50	90	1086	1168	141	700	L170-5790701200000
	6500K	≥ 50	90	1075	1156	140	700	L170-6590701200000

Notes for Table 1:

1. Correlated color temperature is not targeted at $T_j=85^\circ\text{C}$.
2. Luminous flux is based upon mounted package on highly reflective surface at $T_j=25^\circ\text{C}$. There is a tolerance of $\pm 7\%$ on luminous flux measurements.
3. Lumileds maintains a tolerance of ± 2 on CRI (tested to 85°C). Typical CRI is approximately 2 points higher than the minimum CRI specified, but this is not guaranteed.
4. Lumileds maintains a tolerance of ± 6.5 on R9 (tested to 85°C).

Optical Characteristics

Table 2. Optical characteristics for LUXEON 7070 at test current, $T_j=25^\circ\text{C}$.

PART NUMBER	TYPICAL TOTAL INCLUDED ANGLE ^[1]	TYPICAL VIEWING ANGLE ^[2]
L170-xxxx70xx00000	140°	120°

Notes for Table 2:

1. Total angle at which 90% of total luminous flux is captured.
2. Viewing angle is the off axis angle from the LED centerline where the luminous intensity is $\frac{1}{2}$ of the peak value.

Electrical and Thermal Characteristics

Table 3. Electrical and thermal characteristics for LUXEON 7070 at test current, $T_j=25^{\circ}\text{C}$.

PART NUMBER	FORWARD VOLTAGE ^[1] (V_f)			TYPICAL TEMPERATURE COEFFICIENT OF FORWARD VOLTAGE ^[2] (mV/ $^{\circ}\text{C}$)	TYPICAL THERMAL RESISTANCE—JUNCTION TO SOLDER PAD ($^{\circ}\text{C}/\text{W}$)
	MINIMUM	TYPICAL	MAXIMUM		
L170-xxxx701200000	10.5	11.8	12.5	4.5	1.2

Notes for Table 3:

1. Lumileds maintains a tolerance of $\pm 1\%$ on forward voltage measurements.
2. Measured between 25°C and 85°C .

Absolute Maximum Ratings

Table 4. Absolute maximum ratings for LUXEON 7070.

PARAMETER	MAXIMUM PERFORMANCE
DC Forward Current ^[1,2]	1200mA
Peak Pulsed Forward Current ^[1,3]	1440mA
LED Junction Temperature ^[1] (DC & Pulse)	125°C
ESD Sensitivity (ANSI/ESDA/JEDEC JS-001-2012)	2000V
Operating Case Temperature ^[1]	105°C
LED Storage Temperature	-40°C to 105°C
Reverse Voltage (V_{reverse})	LUXEON LEDs are not designed to be driven in reverse bias

Notes for Table 4:

1. Proper current derating must be observed to maintain the junction temperature below the maximum allowable junction temperature.
2. Residual periodic variations due to power conversion from alternating current (AC) to direct current (DC), also called "ripple," are acceptable if the following conditions are met:
 - The frequency of the ripple current is 100Hz or higher
 - The average current for each cycle does not exceed the maximum allowable DC forward current
 - The maximum amplitude of the ripple does not exceed the maximum peak pulsed forward current
3. At 10% duty cycle with pulse width of 10ms.

Characteristic Curves

Spectral Power Distribution Characteristics

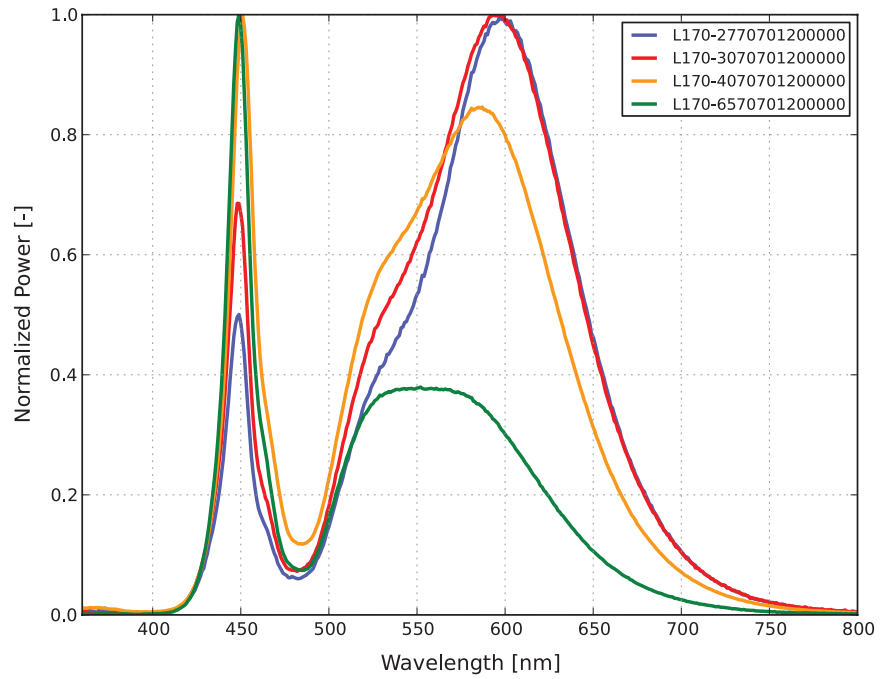

Figure 1a. Typical normalized power vs. wavelength for L170-xx70701200000 at test current, $T_j=25^{\circ}\text{C}$.

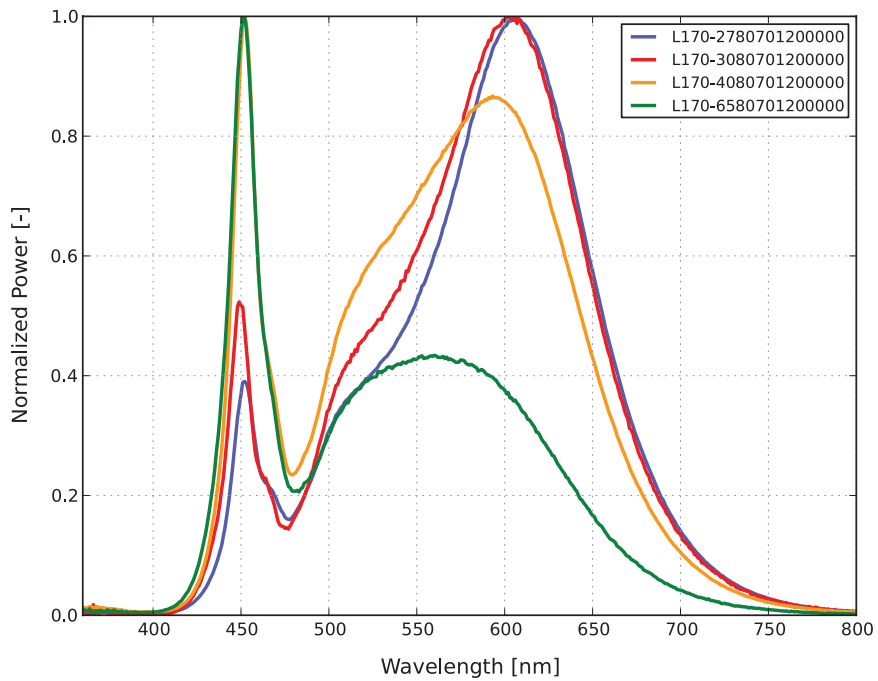

Figure 1b. Typical normalized power vs. wavelength for L170-xx80701200000 at test current, $T_j=25^{\circ}\text{C}$.

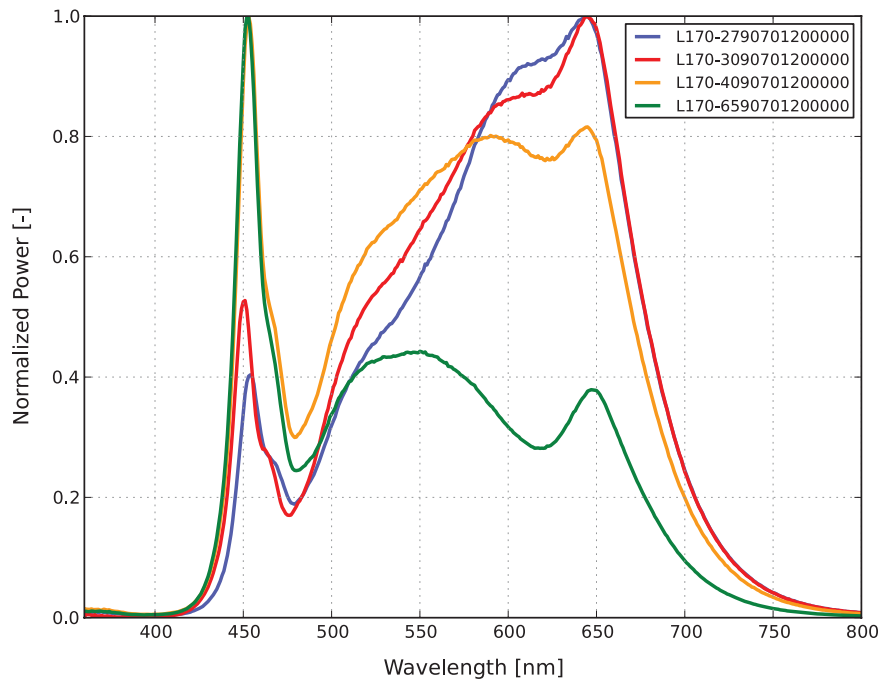

Figure 1c. Typical normalized power vs. wavelength for L170-xx90701200000 at test current, $T_j=25^\circ\text{C}$.

Light Output Characteristics

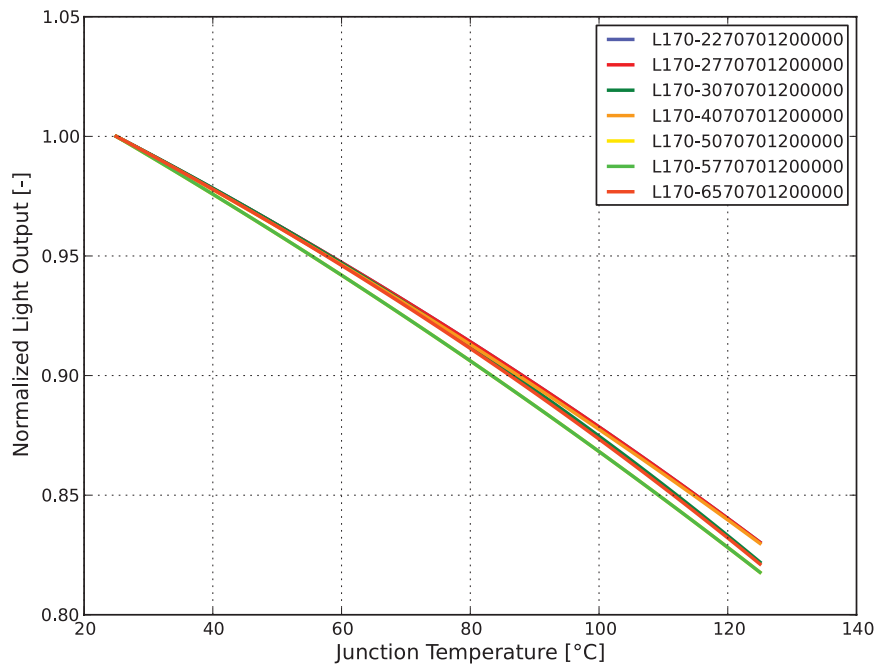

Figure 2a. Typical normalized light output vs. junction temperature for L170-xx70701200000 at test current.

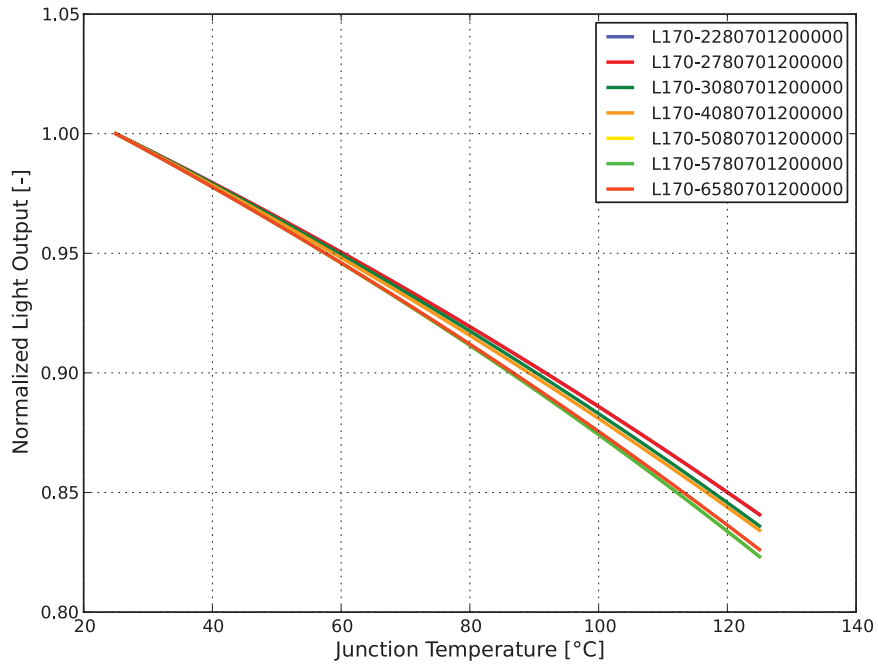

Figure 2b. Typical normalized light output vs. junction temperature for L170-xx80701200000 at test current.

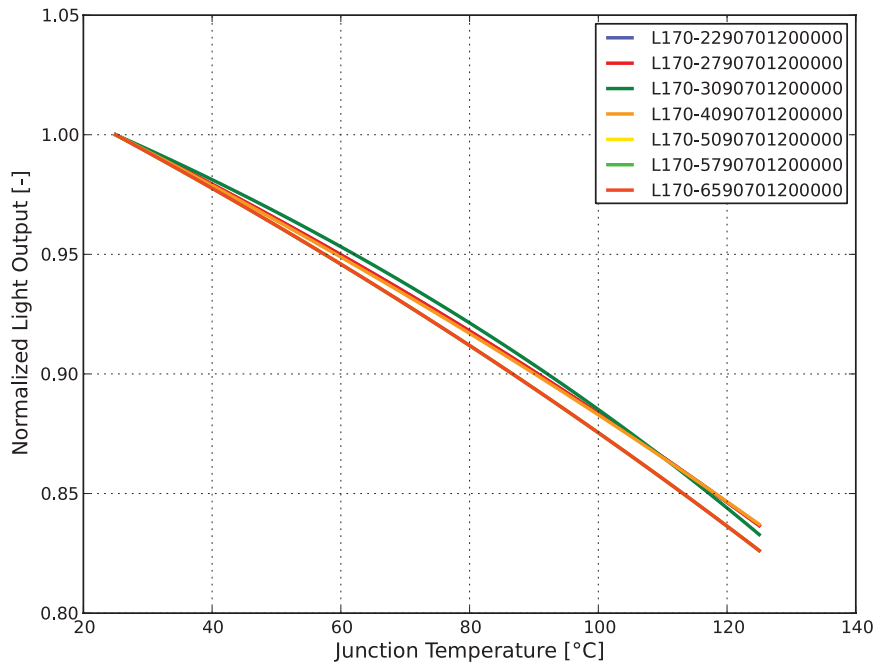

Figure 2c. Typical normalized light output vs. junction temperature for L170-xx90701200000 at test current.

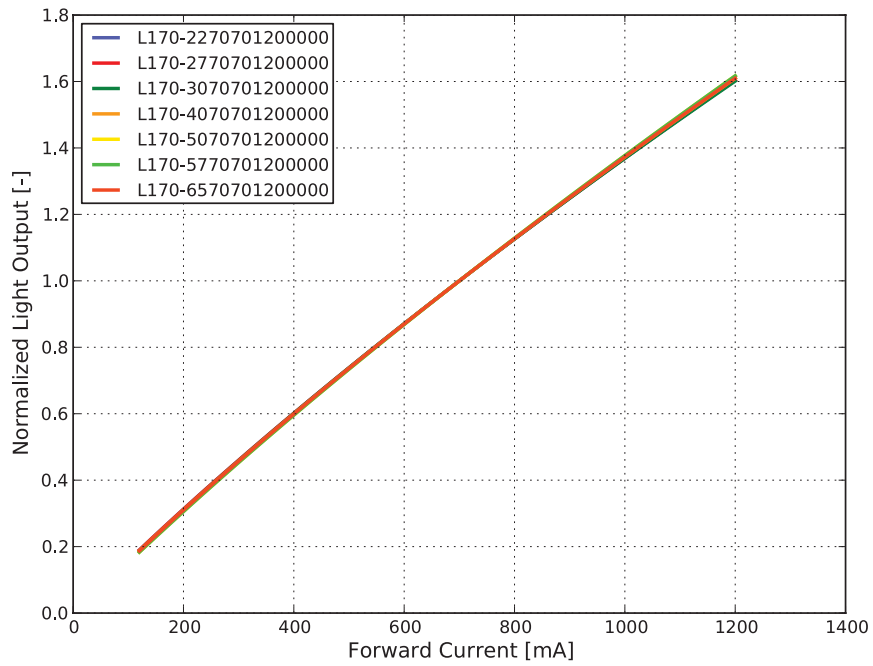

Figure 3a. Typical normalized light output vs. forward current for L170-xx70701200000, $T_j=25^\circ\text{C}$.

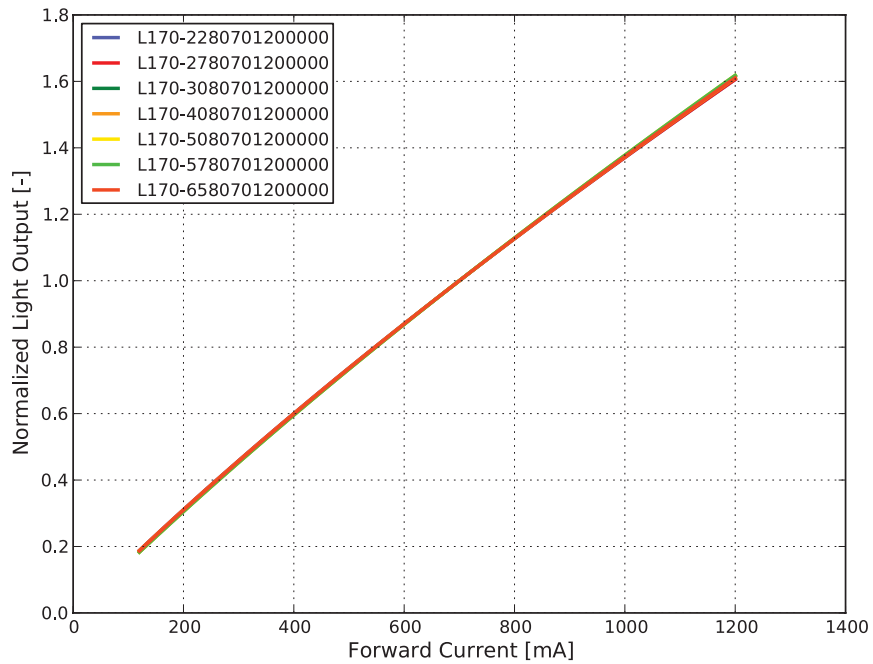

Figure 3b. Typical normalized light output vs. forward current for L170-xx80701200000, $T_j=25^\circ\text{C}$.

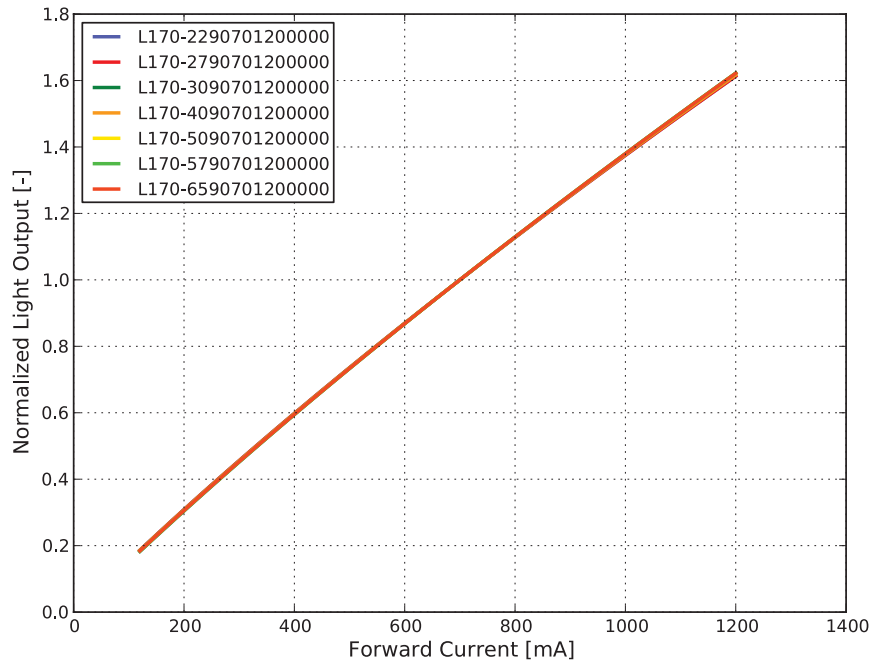

Figure 3c. Typical normalized light output vs. forward current for L170-xx90701200000, $T_j=25^\circ\text{C}$.

Forward Current Characteristics

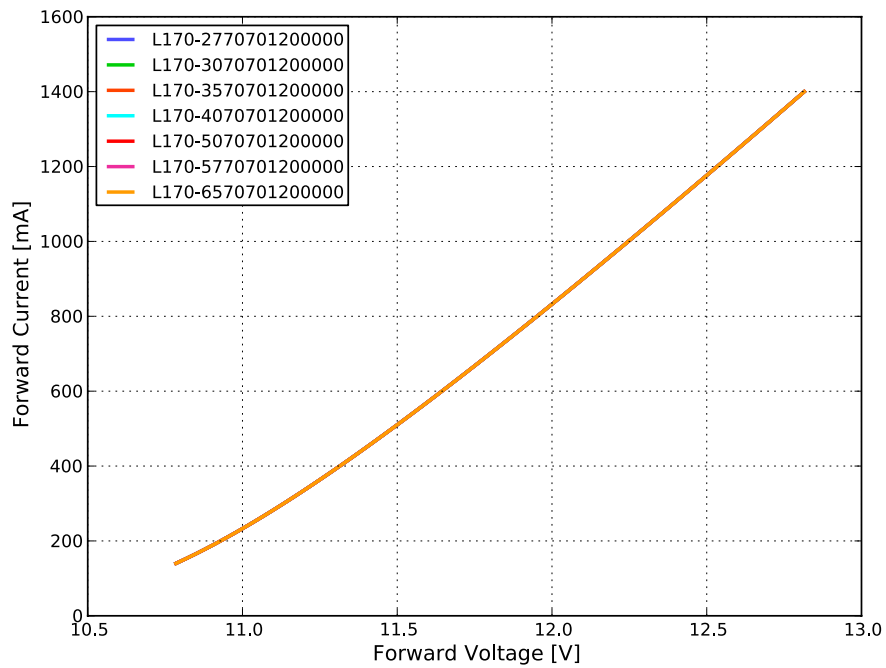

Figure 4a. Typical forward current vs. forward voltage for L170-xx70701200000, $T_j=25^\circ\text{C}$.

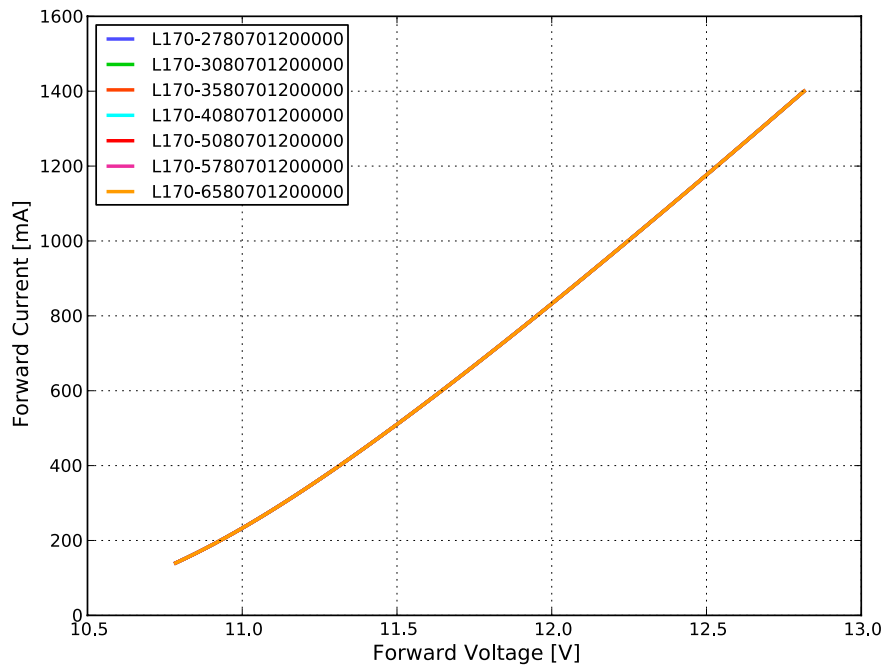

Figure 4b. Typical forward current vs forward voltage for L170-xx80701200000, $T_j=25^\circ\text{C}$.

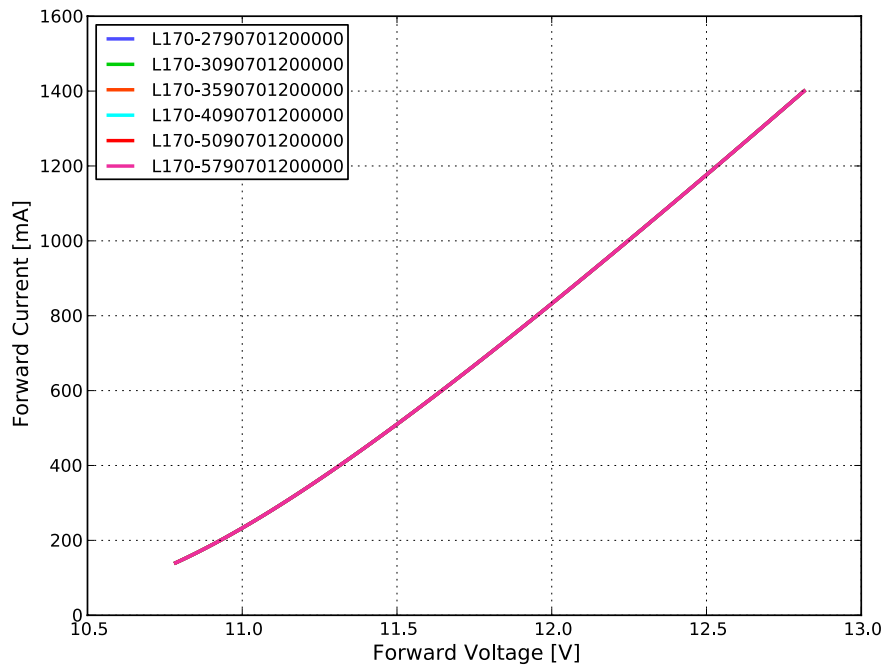

Figure 4c. Typical forward current vs forward voltage for L170-xx90701200000, $T_j=25^\circ\text{C}$.

Radiation Pattern Characteristics

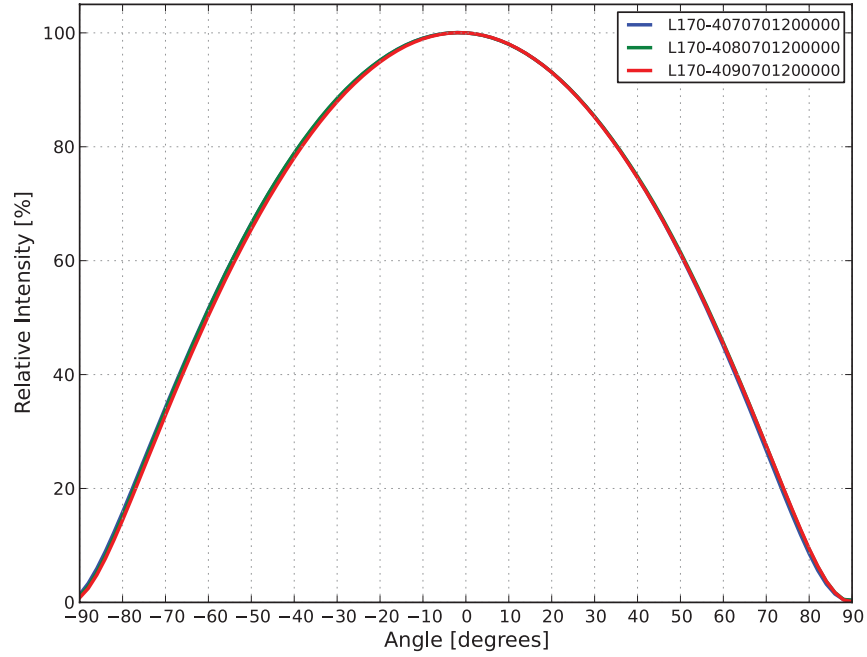

Figure 5. Typical radiation pattern for L170-40xx70xxx0000 at test current, $T_j=25^{\circ}\text{C}$.

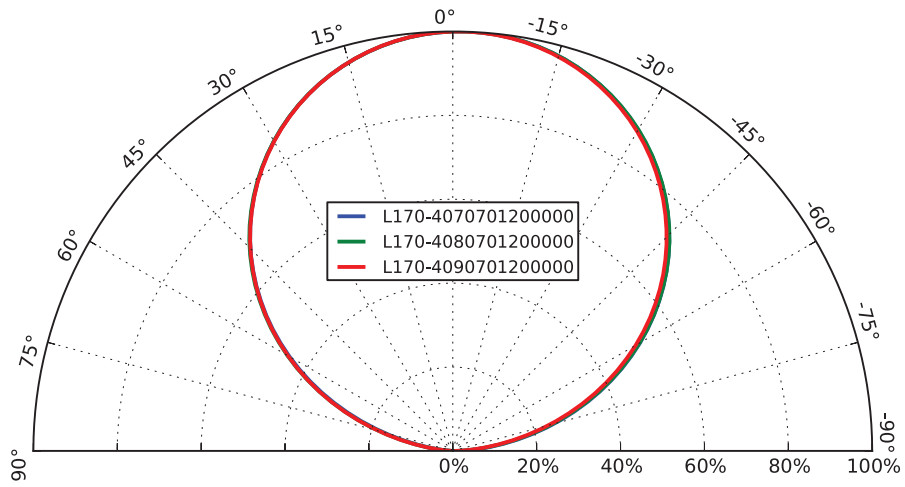

Figure 6. Typical polar radiation pattern for L170-40xx70xxx0000 at test current, $T_j=25^{\circ}\text{C}$.

Product Bin and Labeling Definitions

Decoding Product Bin Labeling

In the manufacturing of semiconductor products, there are variations in performance around the average values given in the technical datasheet. For this reason, Lumileds bins LED components for luminous flux or radiometric power, color point, peak or dominant wavelength and forward voltage.

LUXEON 7070 LEDs are labeled using a 3-digit alphanumeric CAT code following the format below:

A B C D

Where:

- A** – designates luminous flux bin (example: S=1400 to 1450 lumens, T=1450 to 1500 lumens)
- B** – designates color bin (example: 1=6500K, 2=5700K, 3=5000K, 5=4000K, 6=3500K, 7=3000K, 8=2700K, A=2200K)
- C** – designates color space (example: 5=5-step MacAdam ellipse, 3=3-step MacAdam ellipse)
- D** – designates forward voltage bin (example: B=11.0-11.5V, C=11.5 to 12.0V)

Therefore, a LUXEON 7070 with a lumen range of 1400 to 1450, color bin of 3000K, Color space of 3-SDCM and forward voltage range of 11.5 to 12.0V has the following CAT code:

S 7 3 C

Luminous Flux Bins

Table 5 lists the standard luminous flux bins for LUXEON 7070 LEDs. Although several bins are outlined, product availability in a particular bin varies by production run and by product performance. Not all bins are available in all CCTs.

Table 5. Luminous flux bin definitions for LUXEON 7070, $T_j=25^\circ\text{C}$.

BIN	LUMINOUS FLUX ⁽¹⁾ (lm)	
	MINIMUM	MAXIMUM
G	900	950
H	950	1000
J	1000	1050
K	1050	1100
L	1100	1150
M	1150	1200
N	1200	1250
P	1250	1300
Q	1300	1350
R	1350	1400
S	1400	1450
T	1450	1500
U	1500	1550
V	1550	1600

Notes for Table 5:

1. Lumileds maintains a tolerance of $\pm 7\%$ on luminous flux measurements.

Color Bin Definitions

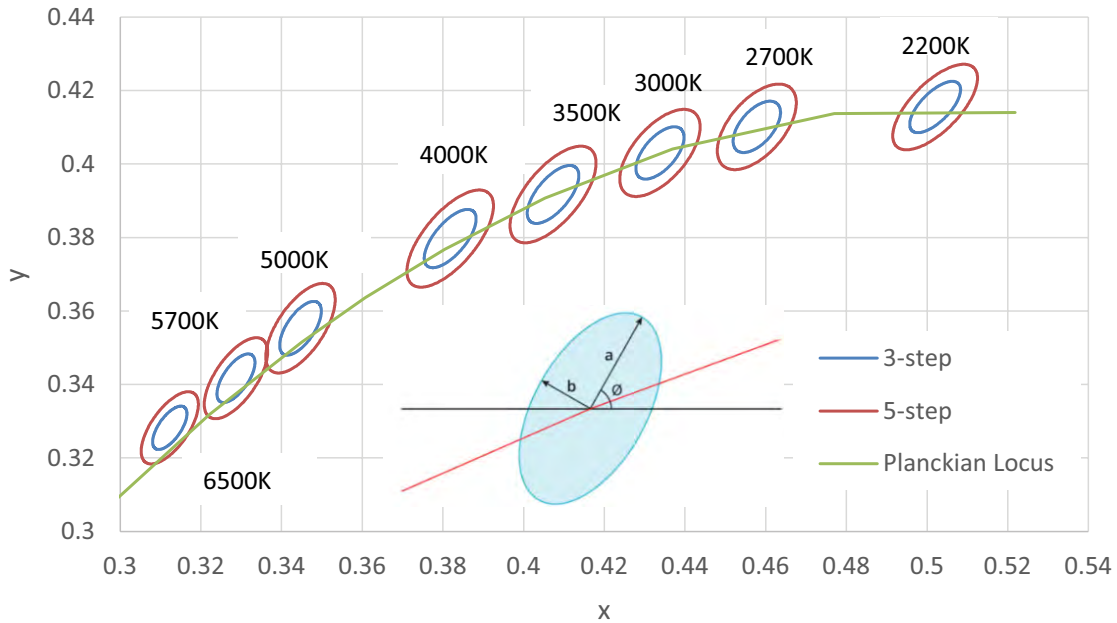

Figure 7. 3- and 5-step MacAdam ellipse illustration for hot-color targeting expected at 85°C.

Table 6. 3- and 5-step MacAdam ellipse color bin definitions for LUXEON 7070 at test current, hot-color targeted at $T_j=85^\circ\text{C}$.

NOMINAL CCT	COLOR SPACE	CENTER POINT ⁽¹⁾ (cx, cy)	MAJOR AXIS, a	MINOR AXIS, b	ELLIPSE ROTATION ANGLE, θ
2200K	Single 3-step MacAdam ellipse	(0.5018, 0.4153)	0.00863	0.00398	49.27°
2700K	Single 3-step MacAdam ellipse	(0.4578, 0.4101)	0.00810	0.00420	53.70°
3000K	Single 3-step MacAdam ellipse	(0.4338, 0.4030)	0.00834	0.00408	53.22°
3500K	Single 3-step MacAdam ellipse	(0.4073, 0.3917)	0.00927	0.00414	54.00°
4000K	Single 3-step MacAdam ellipse	(0.3818, 0.3797)	0.00939	0.00402	53.72°
5000K	Single 3-step MacAdam ellipse	(0.3447, 0.3558)	0.00822	0.00354	59.62°
5700K	Single 3-step MacAdam ellipse	(0.3287, 0.3417)	0.00745	0.00320	59.09°
6500K	Single 3-step MacAdam ellipse	(0.3123, 0.3282)	0.06690	0.00285	58.57°
2200K	Single 5-step MacAdam ellipse	(0.5018, 0.4153)	0.01438	0.00663	49.27°
2700K	Single 5-step MacAdam ellipse	(0.4578, 0.4101)	0.01350	0.00700	53.70°
3000K	Single 5-step MacAdam ellipse	(0.4338, 0.4030)	0.01390	0.00680	53.22°
3500K	Single 5-step MacAdam ellipse	(0.4073, 0.3917)	0.01545	0.00690	54.00°
4000K	Single 5-step MacAdam ellipse	(0.3818, 0.3797)	0.01565	0.00670	53.72°
5000K	Single 5-step MacAdam ellipse	(0.3447, 0.3558)	0.01370	0.00590	59.62°
5700K	Single 5-step MacAdam ellipse	(0.3287, 0.3417)	0.01243	0.00533	59.09°
6500K	Single 5-step MacAdam ellipse	(0.3123, 0.3282)	0.01115	0.00475	59.09°

Notes for Table 6:

1. Lumileds maintains a tolerance of ± 0.01 on x and y coordinates in the CIE 1931 color space.

Table 7. Correlated color temperature bin definitions for LUXEON 7070.

BIN	CCT
1	6500K
2	5700K
3	5000K
5	4000K
6	3500K
7	3000K
8	2700K
A	2200K

Table 8. MacAdam ellipse color space definitions for LUXEON 7070.

BIN	SDCM
3	3-step MacAdam ellipse
5	5-step MacAdam ellipse

Forward Voltage Bins

Table 9. Forward voltage bin definitions for LUXEON 7070, $T_j=25^{\circ}\text{C}$.

VOLTAGE	BIN	FORWARD VOLTAGE ⁽¹⁾ (V_f)	
		MINIMUM	MAXIMUM
12V	A	10.5	11.0
	B	11.0	11.5
	C	11.5	12.0
	D	12.0	12.5

Notes for Table 9:

1. Lumileds maintains a tolerance of $\pm 0.1\text{V}$ on forward voltage measurements.

Mechanical Dimensions

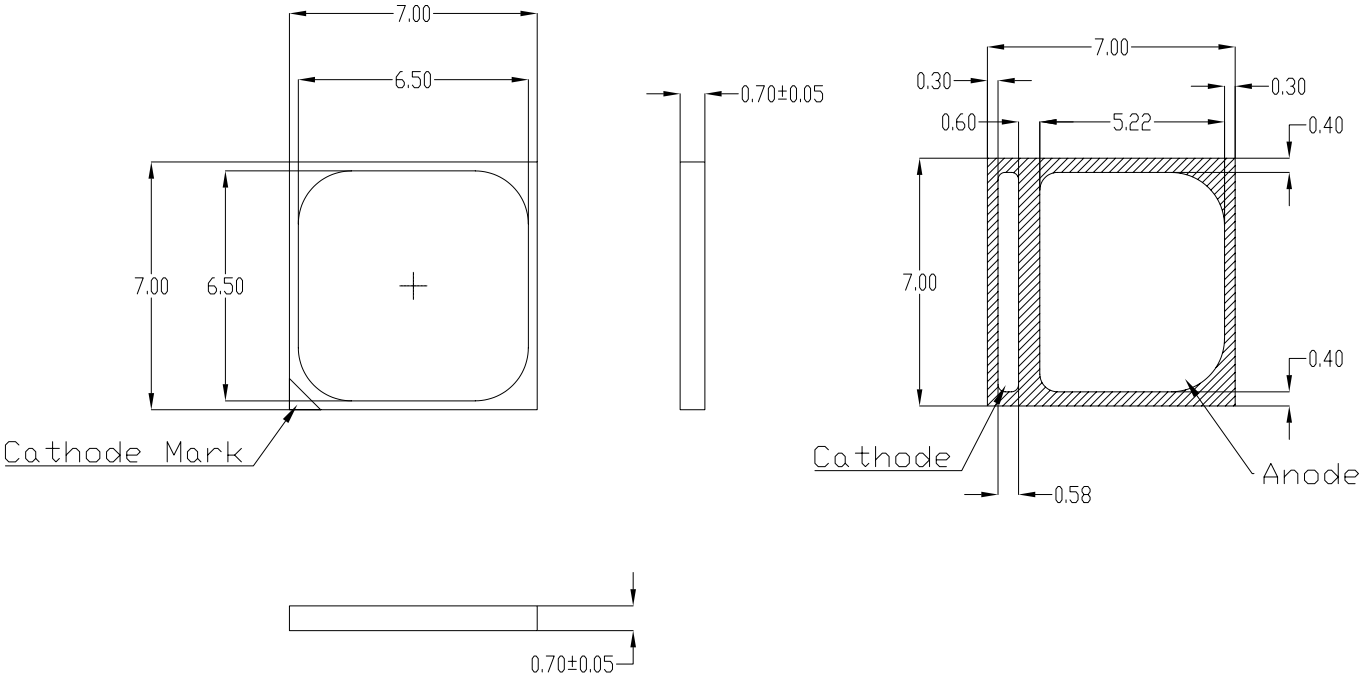

Figure 8. Mechanical dimensions for LUXEON 7070.

- Notes for Figure 8:
1. Drawings are not to scale.
 2. All dimensions are in millimeters.

Reflow Soldering Guidelines

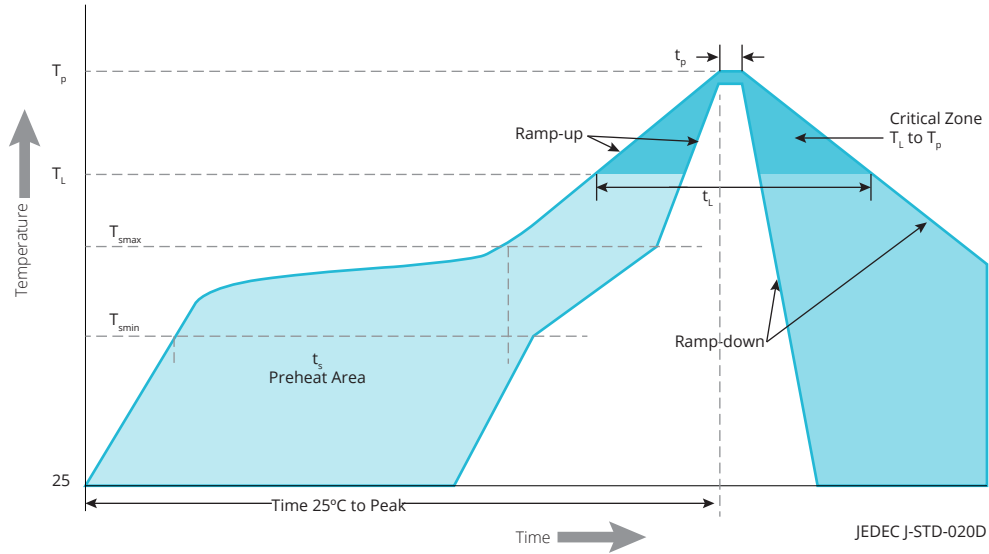

Figure 9. Visualization of the acceptable reflow temperature profile as specified in Table 10.

Table 10. Reflow profile characteristics for LUXEON 7070.

PROFILE FEATURE	LEAD-FREE ASSEMBLY
Preheat Minimum Temperature (T_{smin})	150°C
Preheat Maximum Temperature (T_{smax})	200°C
Preheat Time (t_{smin} to t_{smax})	60 to 180 seconds
Ramp-Up Rate (T_L to T_p)	3°C / second maximum
Liquidus Temperature (T_L)	217°C
Time Maintained Above Temperature T_L (t_t)	60 to 150 seconds
Peak / Classification Temperature (T_p)	260°C
Time Within 5°C of Actual Temperature (t_p)	20 to 40 seconds
Ramp-Down Rate (T_p to T_L)	6°C / second maximum
Time 25°C to Peak Temperature	8 minutes maximum

JEDEC Moisture Sensitivity

Table 11. Moisture sensitivity levels for LUXEON 7070.

LEVEL	FLOOR LIFE		SOAK REQUIREMENTS STANDARD	
	TIME	CONDITIONS	TIME	CONDITIONS
3	168 Hours	≤30°C / 60% RH	192 Hours +5 / -0	30°C / 60% RH

Solder Pad Design

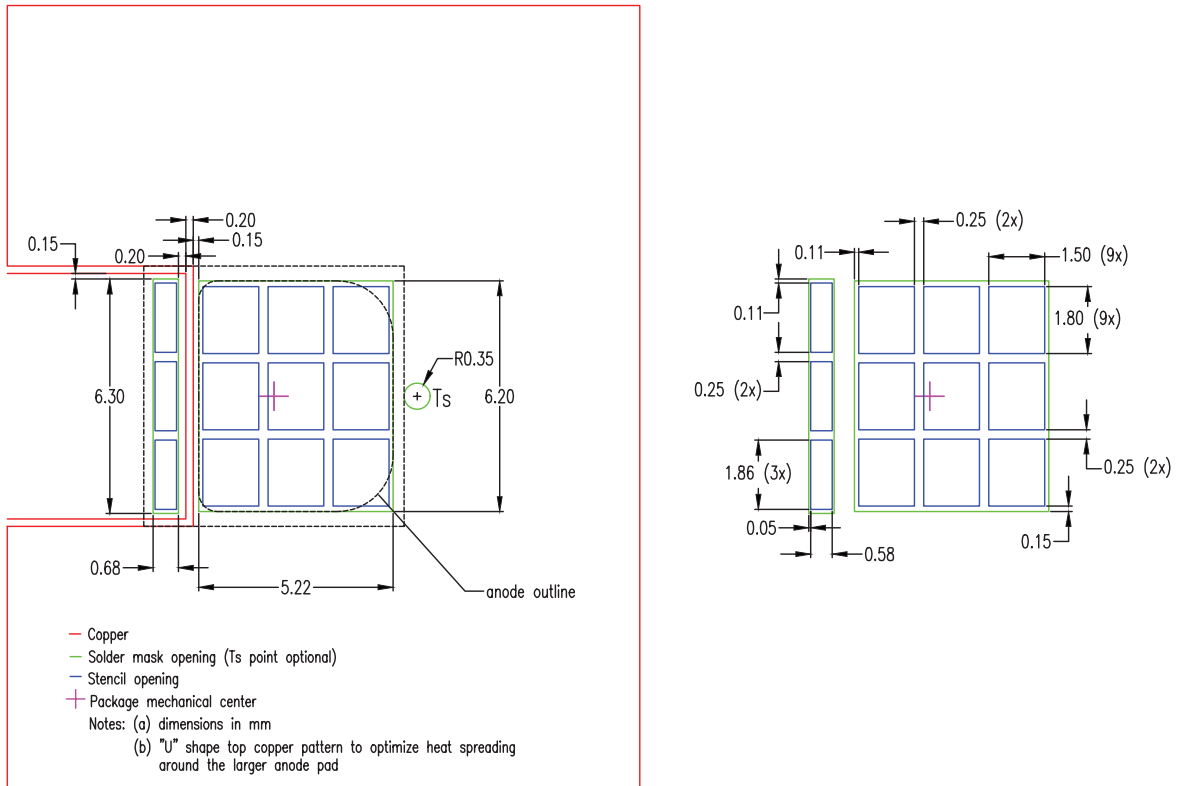

Figure 10. Recommended PCB solder pad layout for LUXEON 7070.

Notes for Figure 10:

1. Drawings are not to scale.
2. All dimensions are in millimeters.

Packaging Information

Pocket Tape Dimensions

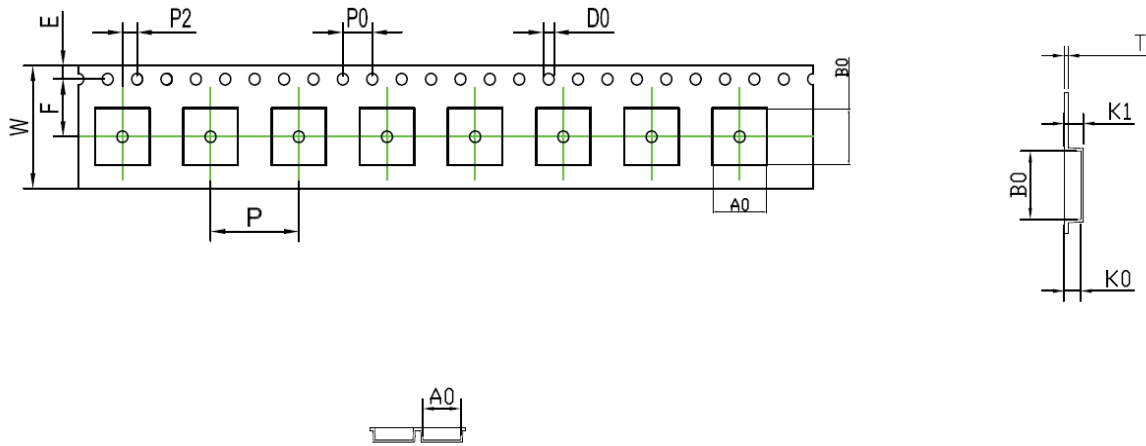

symbol	A0	B0	K0	P0	P	P2	长度/盘
Spec	7.30±0.1	7.30±0.1	1.00±0.1	4.00±0.10	12.0±0.1	2.00±0.10	200M/R
symbol	W	T	E	F	DO	D1	K1
Spec	16.0±0.3	0.30±0.05	1.75±0.10	7.5±0.1	1.50 ^{+0.1} ₋₀	1.50±0.10	1.20±0.1

Figure 11. Pocket tape dimensions for LUXEON 7070.

Notes for Figure 11:

1. Drawings are not to scale.
2. All dimensions are in millimeters.

Reel Dimensions

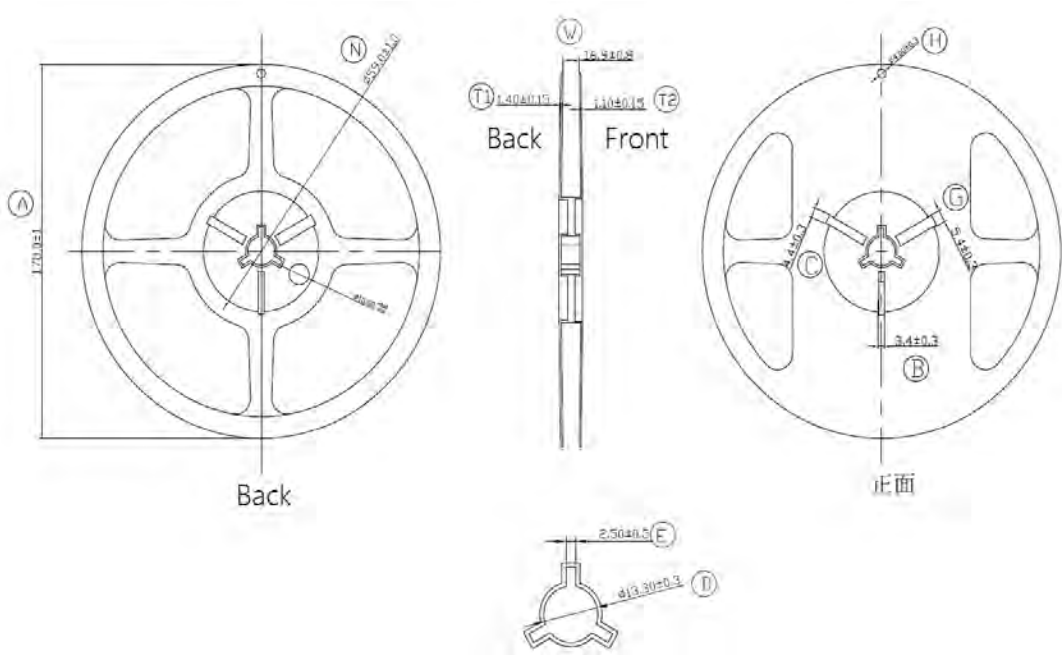

Figure 12. Reel dimensions for LUXEON 7070.

- Notes for Figure 12:
1. Drawings are not to scale.
 2. All dimensions are in millimeters.

About Lumileds

Companies developing automotive, mobile, IoT and illumination lighting applications need a partner who can collaborate with them to push the boundaries of light. With over 100 years of inventions and industry firsts, Lumileds is a global lighting solutions company that helps customers around the world deliver differentiated solutions to gain and maintain a competitive edge. As the inventor of Xenon technology, a pioneer in halogen lighting and the leader in high performance LEDs, Lumileds builds innovation, quality and reliability into its technology, products and every customer engagement. Together with its customers, Lumileds is making the world better, safer, more beautiful—with light.

To learn more about our lighting solutions, visit lumileds.com.



©2021 Lumileds Holding B.V. All rights reserved.
LUXEON is a registered trademark of the Lumileds Holding B.V. in the United States and other countries.
lumileds.com

Neither Lumileds Holding B.V. nor its affiliates shall be liable for any kind of loss of data or any other damages, direct, indirect or consequential, resulting from the use of the provided information and data. Although Lumileds Holding B.V. and/or its affiliates have attempted to provide the most accurate information and data, the materials and services information and data are provided "as is," and neither Lumileds Holding B.V. nor its affiliates warrants or guarantees the contents and correctness of the provided information and data. Lumileds Holding B.V. and its affiliates reserve the right to make changes without notice. You as user agree to this disclaimer and user agreement with the download or use of the provided materials, information and data. A listing of Lumileds product/patent coverage may be accessed at lumileds.com/patents.