

## PM-50 - Analog Input Graphical Panel Meters Installation Guide

- Universal Analog Input: Process, DC voltage, DC current, resistance and temperature inputs
- DC powered, AC powered with optional module
- 4.3" (1/8 DIN) or 3.5" (1/16 DIN) 18-bit color display with resistive touchscreen and swipe gesture
- Choice of programming options
- Data Access Point; communication choices - Wi-Fi®, RS-485/Modbus and optional Ethernet or RS-232
- NEMA 4X/IP65 sealed front bezel

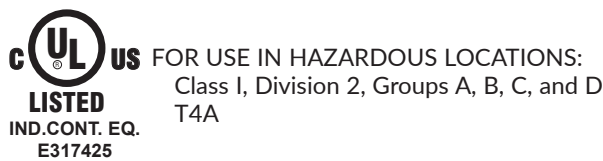

Red Lion declares that the radio equipment type PM50 is manufactured in compliance with Radio Equipment Directive (RED) 2014/53/EU. The full text of the EU declaration of conformity is available at [Declaration Of Conformity \(redlion.net\)](http://Declaration Of Conformity (redlion.net)).

Visit [www.redlion.net](http://www.redlion.net) for how-to videos, full user manual and additional support.

### GENERAL DESCRIPTION

Red Lion's Graphical Panel Meter, PM-50 is a platform of meters designed to increase operator productivity and expose critical plant floor data for use in project scheduling and process improvements. Local operators can easily relate to the more intuitive graphical display. Secondary displays provide even more data. The meters feature on-board Wi-Fi, RS-485/Modbus, and optional Ethernet or RS-232.

PM-50 features a 4.3" or 3.5" Color Graphical Touchscreen. With an appearance like many smart devices, the display includes a status bar and menu selections for easy operation. Recognizing a swipe gesture allows multiple screens to be accessed. Touchscreen push buttons can be displayed on the screen or hidden during operation. The meters mount in standard industrial hole sizes, 1/8 DIN and 1/16 DIN respectively.

On power-up, a Programming Wizard will assist you to get started. You may also select a Programming App, Web Server, or the traditional button/menu style for your programming needs. For OEM customers a microSD Card allows for quick programming and installation, saving time and money.

The meters offer universal inputs allowing a variety of sensors to serve as the input. The Analog Signal includes DC Current, DC Voltage, Process, Resistance, and Temperature. Onboard outputs include dual Solid State Outputs adjustable for sinking or sourcing applications. User inputs are also available to provide external interface and control when required.

The PM-50 platform includes modular construction to add additional capabilities. External modules can easily be installed in the field to add a variety of output and communication options. As safety advances through the Automation Industry, DC is the more common choice for power. However, there are still many requirements for AC power and they can be accommodated with our AC to DC Power Module.

### PACKAGE CHECKLIST

This product package should contain the items listed below. If any items are missing or damaged, contact Red Lion immediately.

- PM-50 Analog Input Panel Meter
- Accessory Pack
- Installation Guide

### SAFETY SUMMARY

All safety related regulations, local codes and instructions that appear in this document or on equipment must be observed to ensure personal safety and to prevent damage to either the device or equipment connected to it.

Do not use these products to replace proper safety interlocking. No software-based device (or any other solid-state device) should ever be designed to be responsible for the maintenance of personnel safety or consequential equipment not equipped with safeguards. Red Lion disclaims any responsibility for damages, either direct or consequential, that result from the use of this equipment in a manner not specified.



#### CAUTION: Risk of Danger

Read complete instructions prior to installation and operation of the unit.

#### ATTENTION : Risque de danger

Lire les instructions complètes avant l'installation et l'utilisation de l'appareil.



**WARNING - EXPLOSION HAZARD -** When in hazardous locations, disconnect power before replacing or wiring modules.

**AVERTISSEMENT - RISQUE D'EXPLOSION -** Dans les endroits dangereux, débranchez l'alimentation électrique avant de remplacer ou de câbler les modules.



This equipment is suitable for use in Class I, Division 2, Groups A, B, C, D, or non-hazardous locations only.

Cet équipement est adapté à une utilisation dans des endroits de classe I, Division 2, Groupes A, B, C, D, ou dans des endroits non dangereux seulement.

### GENERAL METER SPECIFICATIONS

**Note:** The PM-50 4.3 inch host accepts a maximum of 5 modules while the 3.5 inch host accepts a maximum of 3 modules. Only one module from each function type (i.e. communication, relay, analog output) can be installed.

- POWER:** The meter is intended to be powered by NEC/CEC class 2, IEC/EN/UL 60950-1 LPS or UL/CSA 601010-1 Limited Energy power source.

MODEL	4.3-INCH	3.5-INCH
Input Voltage (Volts)	10-30 VDC	10-30 VDC
Max Power PM-50 only	4.6 W	4.6 W
Max Power PM-50, with modules	12 W	12 W

Host Isolation: 500 Vrms for 1 min. to all inputs and outputs.

- DISPLAY:** 4.3" or 3.5" Color TFT display with resistive analog touch screen

SIZE	4.3-INCH	3.5-INCH
TYPE	TFT	TFT
COLORS	262,144	262,144
PIXELS	480 X 272	320 X 240
BRIGHTNESS	420 cd/m <sup>2</sup>	540 cd/m <sup>2</sup>
LED BACKLIGHT LIFE*	30,000 HR TYP.	30,000 HR TYP.

\* Lifetime at room temperature (25°C)

- A/D CONVERTER:** 24 bit resolution

- UPDATE RATES:**

A/D Conversion Rate: Programmable 5 to 200 readings/sec.  
Step Response:

Input Type (Readings/Sec)	INPUT UPDATE RATE (msec RESPONSE TIME *)				
	10	20	50	100	200
V/I/Resistance	200	100	40	20	10
Thermocouple	250	100	-	-	-
RTD	500	250	-	-	-

\* - max. to within 99% of final readout value (digital filter disabled)

Display Update Rate: 1 to 20 updates/sec.

Setpoint Output ON/OFF Delay Time: 0 to 3275 sec.

Max./Min. Capture Delay Time: 0 to 3275 sec.

- INPUT CAPABILITIES:**

**Current Input:**

MAX INPUT RANGE	ACCURACY* (18 to 28 °C)	ACCURACY* (-10 to 55 °C)	IMPEDANCE	RESOLUTION
± 200 µA DC	0.03% of rdg + 0.03 µA	0.12% of rdg + 0.04 µA	100 Ω	10 nA
± 2 mA DC	0.03% of rdg + 0.3 µA	0.12% of rdg + 0.4 µA	100 Ω	0.1 µA
± 20 mA DC	0.03% of rdg + 3 µA	0.12% of rdg + 4 µA	100 Ω	1 µA
± 200 mA DC	0.05% of rdg + 30 µA	0.12% of rdg + 40 µA	0.06 Ω	10 µA
± 2 A DC	0.5% of rdg + 0.3 mA	0.7% of rdg + 0.4 mA	0.06 Ω	0.1 mA

**Voltage Input:**

Impedance: 625 KΩ

MAX INPUT RANGE	ACCURACY* (18 to 28 °C)	ACCURACY* (-10 to 55 °C)	RESOLUTION
± 200 mV DC	0.03% of rdg + 30 µV	0.12% of rdg + 40 µV	10 µV
± 2.0 V DC	0.03% of rdg + 0.3 mV	0.12% of rdg + 0.4 mV	0.1 mV
± 20 V DC	0.03% of rdg + 3 mV	0.12% of rdg + 4 mV	1 mV
± 60 V DC	0.3% of rdg + 30 mV	0.12% of rdg + 40 mV	10 mV

**Thermocouple Inputs:**

Readout Scale: °F or °C

Input Impedance: 20 MΩ

Lead Resistance Effect: 0.09 µV/Ω

Max Continuous Overvoltage: 30 V

INPUT TYPE	RANGE	ACCURACY* (18 to 28 °C)	ACCURACY* (-10 to 55 °C)	STANDARD	WIRE COLOR	
					ANSI	BS 1843
T	-200 to 400 °C	1.2 °C	2.1 °C	ITS-90	(+) blue (-) red	(+) white (-) blue
E	-200 to 750 °C	1.0 °C	2.4 °C	ITS-90	(+) purple (-) red	(+) brown (-) blue
J	-200 to 760 °C	1.1 °C	2.3 °C	ITS-90	(+) white (-) red	(+) yellow (-) blue
K	-200 to 1250 °C	1.3 °C	3.4 °C	ITS-90	(+) yellow (-) red	(+) brown (-) blue
R	0 to 1768 °C	1.9 °C	4.0 °C	ITS-90	no standard	(+) white (-) blue
S	0 to 1768 °C	1.9 °C	4.0 °C	ITS-90	no standard	(+) white (-) blue
B	150 to 300 °C 300 to 1820 °C	3.9 °C 2.8 °C	5.7 °C 4.4 °C	ITS-90	no standard	no standard
N	-200 to 1300 °C	1.3 °C	3.1 °C	ITS-90	(+) orange (-) red	(+) orange (-) blue
C (W5/W26)	0 to 2315 °C	1.9 °C	6.1 °C	ASTM E988-90**	no standard	no standard

**RTD Inputs:**

Readout Scale: °F or °C

Type: 3 or 4 wire, 2 wire can be compensated for lead wire resistance

Excitation Current: 100 Ω range: 136.5 µA ±10%

10 Ω range: 2.05 mA ±10%

Lead Resistance: 100 Ω range: 10 Ω/lead max.

10 Ω range: 3 Ω/lead max.

Max. Continuous Overload: 20 VDC

INPUT TYPE	RANGE	ACCURACY* (18 to 28 °C)	ACCURACY* (-10 to 55 °C)	STANDARD **
100 Ω Pt alpha = .00385	-200 to 850 °C	0.4 °C	1.6 °C	IEC 751
100 Ω Pt alpha = .00392	-200 to 850 °C	0.4 °C	1.6 °C	no official standard
120 Ω Nickel alpha = .00672	-80 to 259 °C	0.2 °C	0.5 °C	no official standard
10 Ω Copper alpha = .00427	-110 to 260 °C	0.4 °C	0.9 °C	no official standard

**Resistance Inputs:**

Max. Continuous Overload: 20 VDC

MAX INPUT RANGE	ACCURACY* (18 to 28 °C)	ACCURACY* (-10 to 55 °C)	COMPLIANCE	‡ RESOLUTION
100 Ω	0.05% of rdg +0.3 Ω	0.2% of rdg +0.4 Ω	0.175 V	0.1 Ω
1000 Ω	0.05% of rdg+0.3 Ω	0.2% of rdg +0.4 Ω	1.75 V	1 Ω
10 KΩ	0.05% of rdg +1 Ω	0.2% of rdg +1.5 Ω	17.5 V	1 Ω

‡ Higher resolution can be achieved via input scaling.

\* After 20 min. warm-up, @ 10 sample per second input rate. Accuracy is specified in two ways: Accuracy over an 18 to 28 °C and 15 to 75% RH environment; and Accuracy over a -10 to 55 °C and 0 to 85% RH (non condensing) environment. The specification includes the A/D conversion errors, linearization conformity, and thermocouple ice point compensation. Total system accuracy is the sum of unit and probe errors. Accuracy may be improved by field calibrating the unit readout at the temperature of interest.

\*\* These curves have been corrected to ITS-90.

**6. EXCITATION POWER:**

Transmitter Power: +24 VDC, ± 5% @ 50 mA max.

Reference Voltage: + 2 VDC, ± 2%

Compliance: 1 KΩ load min (2 mA max)

Temperature Coefficient: 40 ppm/°C max.

Reference Current: 1.05 mADC, ± 2%

Compliance: 10 KΩ load max (2 mA max)

Temperature Coefficient: 40 ppm/°C max.

**7. USER INPUTS:** Two programmable user inputs

Max. Continuous Input: 30 VDC

Isolation to Sensor Input Common: Not isolated.

Logic State: User programmable for sink/source (Lo/Hi)

INPUT STATE	LO/SINK	HI/SOURCE
	20 KΩ pull-up to +3.3 V	20 KΩ pull-down
Active	V <sub>IN</sub> < 0.9 VDC	V <sub>IN</sub> > 2.4 VDC
Inactive	V <sub>IN</sub> > 2.4 VDC	V <sub>IN</sub> < 0.9 VDC

**8. TOTALIZER:**

Time Base: second, minute, hour, or day

Batch: Can accumulate (gate) input display from a user input

Time Accuracy: 0.01% typical

Decimal Point: 0 to 0.0000

Scale Factor: 0.001 to 65.000

Low Signal Cut-out: -199,999 to 999,999

Total: Up to 9 digits

**9. CUSTOM LINEARIZATION:**

Data Point Pairs: Selectable from 2 to 40

Display Range: -199,999 to 999,999

Decimal Point: 0 to 0.0000

**10. MEMORY:** Nonvolatile memory retains all programmable parameters and display values.

Memory Card: microSD slot accepts up to 32 GB capacity cards in FAT16/FAT32 format.

**11. RS485 SERIAL PORT:** Uses Modbus protocol

Baud Rate: Up to 115,200

Data Format: 7/8 bit; odd, even, or no parity; 1 or 2 stop bits

Isolation: 500 Vrms to sensor, user power and digital inputs.

Not isolated to solid state outputs

**12. Wi-Fi CAPABILITIES:**

Wi-Fi: Power output up to 20.5 dBm

Frequency:

TECHNOLOGY	CHANNELS	FREQUENCIES
Wi-Fi	1-13	2412-2484 MHz

Note: Channel/frequency limitation is enforced based on configured country/region code.

Wi-Fi Compliance: TCP/IP; 802.11 b/g/n

**13. ON-BOARD DUAL SSR OUTPUTS:** Both outputs must be used either in SINKING or in SOURCING mode together.

Sinking Mode:

Type: Switched DC, N-channel open drain MOSFET

Max Sink Current: 100 mA

V<sub>DS</sub> ON: 0.3 V @ 100 mA

V<sub>DS</sub> MAX: 30 VDC

Offstate Leakage Current: 0.5 mA max

Sourcing Mode:

Type: Switched DC, P-channel open source MOSFET

Max Source Current: 100 mA

V<sub>DS</sub> ON: 0.3 V @ 100 mA

V<sub>DS</sub> MAX: 30 VDC

Offstate Leakage Current: 0.5 mA max

**14. ENVIRONMENTAL CONDITIONS:**

Operating Temperature Range: -10 to 55 °C

Storage Temperature Range: -20 to 60 °C

Operating and Storage Humidity: 0 to 85% max. RH non-condensing

Vibration to IEC 68-2-6: Operational 5-500 Hz, 2 g

Shock to IEC 68-2-27: Operational 20 g (10 g relay)

Altitude: Up to 2000 meters

Installation Category II, Pollution Degree 2 as defined in IEC/EN 60664-1.

**15. CERTIFICATIONS AND COMPLIANCES:**

**CE Approved**

EN 61326-1 Immunity to Industrial Locations

Emission CISPR 11 Class A

IEC/EN 61010-1

RoHS Compliant

FCC ID #: 2AC7Z-ESP32WROOM32U

UL Hazardous: File # E317425

Type 4X Indoor/IP65 Enclosure rating (Face only) for all models IP20 Enclosure rating (Rear of unit)

**16. CONNECTIONS:** High compression spring-clamp terminal block

Wire Strip Length: 0.32-0.35" (8-9 mm)

Wire Gauge Capacity: Four 28 AWG (0.32 mm) solid, two 20 AWG (0.61 mm) or one 16 AWG (2.55 mm)

**17. CONSTRUCTION:** This unit is rated NEMA 4X/IP65 for indoor use only. IP20 Touch safe. One piece bezel/ case. Flame resistant. Panel gasket, module locks, and mounting panel latch included.

**18. MOUNTING REQUIREMENTS:** Maximum panel thickness is 0.25" (6.35 mm). For NEMA 4X/IP65 sealing, a steel panel with a minimum thickness of 0.04" (1.02 mm) is recommended.

Panel Latch Screw Torque: 5.0 lbf-in (0.56 Nm) **CAUTION: DO NOT OVERTIGHTEN**

**19. WEIGHT:**

4.3: 11.3 oz (321 g)

3.5: 7.9 oz (224 g)

**DIMENSIONS In inches (mm)**

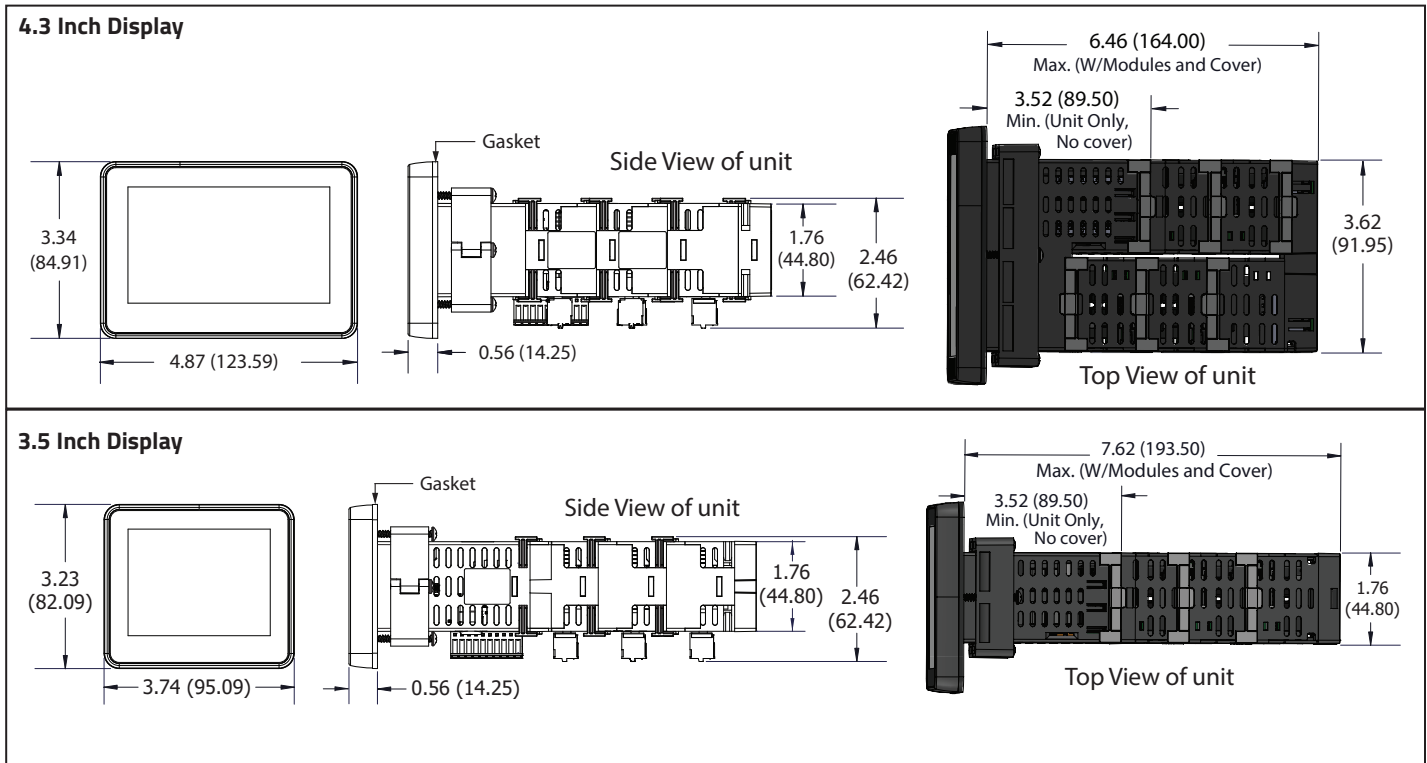

**INSTALLATION ENVIRONMENT**

The unit should be installed in a location that does not exceed its own operating temperature and provides good air circulation. Placing the unit near devices that generate excessive heat should be avoided.

The PM-50 4.3 and 3.5 inch models meet NEMA 4X/IP65 requirements when properly installed. This unit is designed for through-panel mounting. The mounting surface should have a minimum thickness of 0.04" (1.02 mm) and maximum thickness of 0.25" (6.35 mm). Cut the mounting hole per the dimensions shown in the diagram. Care should be taken to remove any loose material from the mounting cut-out to prevent that material from falling into the unit during installation. Prepare the panel cutout to the dimensions shown.

For hazardous location installation the following shall be taken into consideration:

- The device shall be panel mounted in a tool accessible enclosure with a minimum ingress protection rating of at least IP64 as defined in IEC/EN 60529.
- This device is open-type and must be mounted in a suitable dust-tight end-enclosure in accordance with articles 500 and 502 of the NEC and positioned so only the face of the display is exposed.
- Must be wired using Division 2 wiring methods as specified in article 501-4(b), 502-4(b), and 503-3(b) of the National Electric Code, NFPA 70 for installation within the United States, or as specified in section 19-152 of Canadian Electrical Code for installation in Canada.

**4.3 Inch Meter**

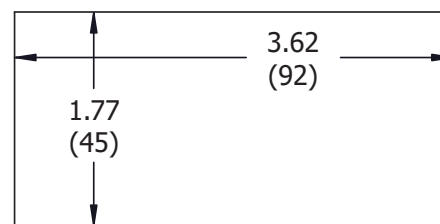

**3.5 Inch Meter**

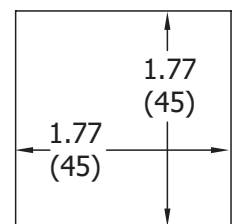

**METER INSTALLATION**

Slide the panel gasket over the rear of the unit to the back of the bezel. The unit should be installed fully assembled. Insert the unit into the panel cutout.

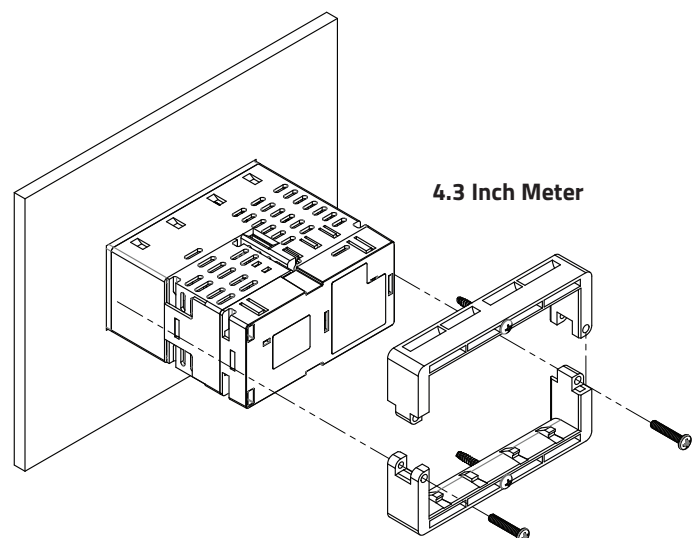



While holding the unit in place, place either the top or bottom panel latch on the rear of the unit closest to the panel cutout so that the tabs of the panel latch engage in the slots on the case. Repeat this process with the other half of the panel latch. Secure the latch with the panel mounting screws provided. To achieve a proper seal, tighten the latch screws evenly until the unit is snug in the panel (Torque to approximately 5 in-lbs [56 N-cm]). Do not over-tighten the screws.

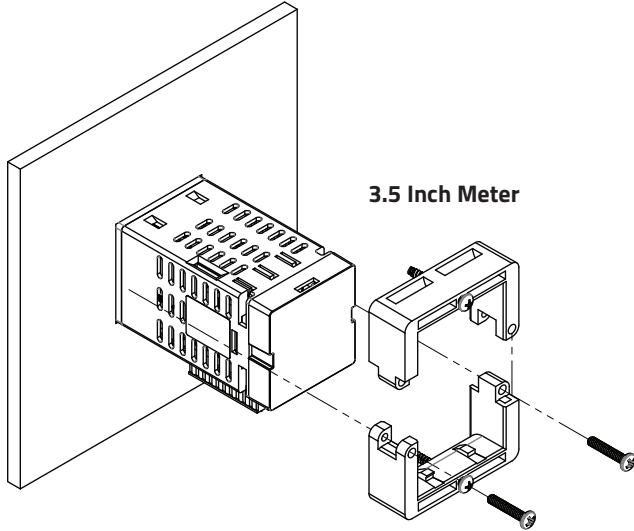

**EMC INSTALLATION GUIDELINES**

Although Red Lion Controls products are designed with a high degree of immunity to Electromagnetic Interference (EMI), proper installation and wiring methods must be followed to ensure compatibility in each application. The type of the electrical noise, source or coupling method into a unit may be different for various installations. Cable length, routing, and shield termination are very important and can mean the difference between a successful or troublesome installation. Listed are some EMI guidelines for a successful installation in an industrial environment.

1. A unit should be mounted in a metal enclosure, which is properly connected to protective earth.
2. Use shielded cables for all Signal and Control inputs. The shield connection should be made as short as possible. The connection point for the shield depends somewhat upon the application. Listed below are the recommended methods of connecting the shield, in order of their effectiveness.
  - a. Connect the shield to earth ground (protective earth) at one end where the unit is mounted.
  - b. Connect the shield to earth ground at both ends of the cable, usually when the noise source frequency is over 1 MHz.
3. Never run Signal or Control cables in the same conduit or raceway with AC power lines, conductors, feeding motors, solenoids, SCR controls, and heaters, etc. The cables should be run through metal conduit that is properly grounded. This is especially useful in applications where cable runs are long and portable two-way radios are used in close proximity or if the installation is near a commercial radio transmitter. Also, Signal or Control cables within an enclosure should be routed as far away as possible from contactors, control relays, transformers, and other noisy components.
4. Long cable runs are more susceptible to EMI pickup than short cable runs.
5. In extremely high EMI environments, the use of external EMI suppression devices such as Ferrite Suppression Cores for signal and control cables is effective. The following EMI

suppression devices (or equivalent) are recommended:  
 Fair-Rite part number 0443167251 (Red Lion #FCOR0000)  
 Line Filters for input power cables:

Schaffner # FN2010-1/07 (Red Lion #LFIL0000)

6. To protect relay contacts that control inductive loads and to minimize radiated and conducted noise (EMI), some type of contact protection network is normally installed across the load, the contacts or both. The most effective location is across the load.
  - a. Using a snubber, which is a resistor-capacitor (RC) network or metal oxide varistor (MOV) across an AC inductive load is very effective at reducing EMI and increasing relay contact life.
  - b. If a DC inductive load (such as a DC relay coil) is controlled by a transistor switch, care must be taken not to exceed the breakdown voltage of the transistor when the load is switched. One of the most effective ways is to place a diode across the inductive load. Most Red Lion products with solid state outputs have internal zener diode protection. However external diode protection at the load is always a good design practice to limit EMI. Although the use of a snubber or varistor could be used.  
 Red Lion part numbers: Snubber: SNUB0000  
 Varistor: ILS11500 or ILS23000
7. Care should be taken when connecting input and output devices to the instrument. When a separate input and output common is provided, they should not be mixed. Therefore a sensor common should NOT be connected to an output common. This would cause EMI on the sensitive input common, which could affect the instrument's operation.

Visit <http://www.redlion.net/emi> for more information on EMI guidelines, Safety and CE issues as they relate to Red Lion products.

**WIRING**

All power, input and output (I/O) wiring must be in accordance with Class 1, Division 2 wiring methods and in accordance with the authority having jurisdiction. Electrical connections are made via pluggable spring-clamp terminal blocks. It is recommended that the power supplied to the meter be protected by a fuse or circuit breaker.

When wiring the meter, refer to the label on the unit for pin-out numbering against those shown in the wiring drawings for proper wire position. Strip and connect the wire according to the terminal block specifications on Page 3. Use a small screwdriver to press down on tab next to the terminal position to open the spring clamp. Insert the wire into the terminal position and then remove the screwdriver to engage the spring-clamp.

**POWER WIRING**

Must use a Class 2 circuit according to National Electrical Code (NEC), NFPA-70 or Canadian Electrical Code (CEC), Part I, C22.1 or a Limited Power Supply (LPS) according to IEC/EN 60950-1 or Limited-energy circuit according to IEC/EN 61010-1.

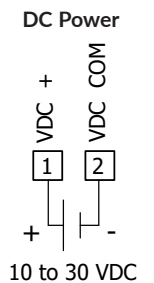



**CAUTION:** Sensor input common is NOT isolated from user input common. In order to preserve the safety of the controller application, the sensor input common must be suitably isolated from hazardous live earth referenced voltages; or input common must be at protective earth ground potential. If not, hazardous live voltage may be present at the User Inputs and User Input Common terminals. Appropriate considerations must then be given to the potential of the user input common with respect to earth common, and the common of the isolated plug-in modules with respect to input common.

**IMPORTANT:** Before connecting signal wires, verify input range and excitation is set for proper type.

## VOLTAGE INPUT WIRING

### Voltage Input Signal

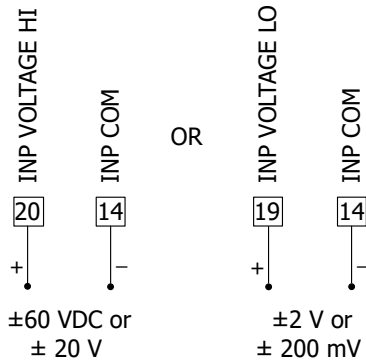

### Voltage Input Signal (3 wire requiring excitation)

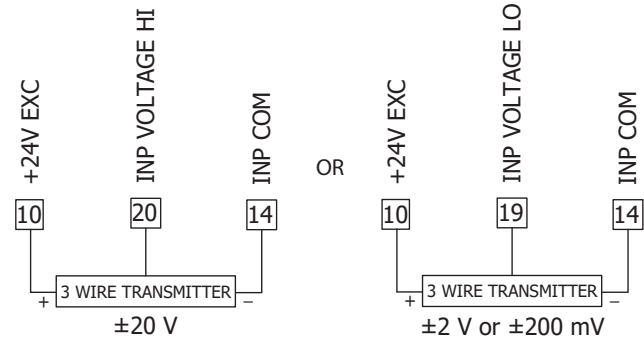

## PROCESS/CURRENT WIRING

### Process/Current Signal (external powered)

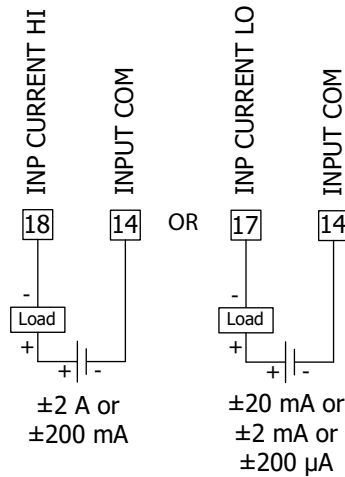

### Process/Current Signal (2 wire requiring excitation)

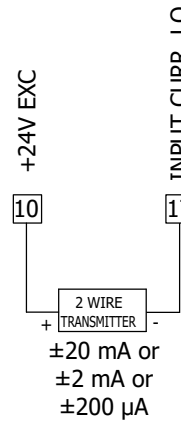

### Process/Current Signal (3 wire requiring excitation)

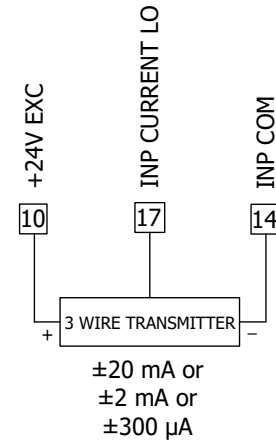

## TEMPERATURE INPUT WIRING

### Thermocouple

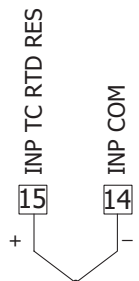

### 3-Wire RTD

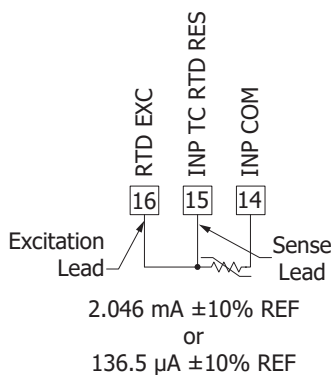

### 2-Wire RTD

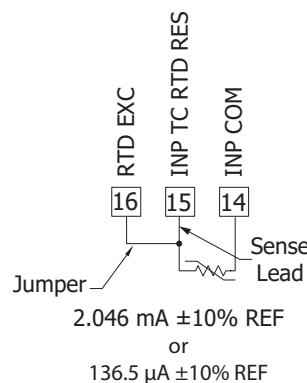

## RESISTANCE WIRING

### Resistance Signal (3 wire requiring excitation)

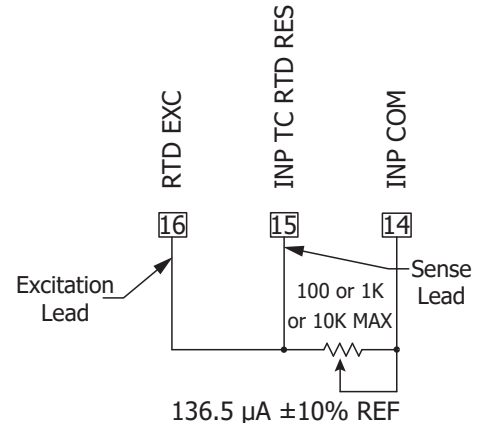

## USER INPUT WIRING

User Input terminal does not need to be wired in order to remain in the inactive state.

### Sinking Logic

When the parameter is programmed to Low, check with device GUI option. The user inputs of the controller are internally pulled up to +3.3 V with 20 KΩ resistance. The input is active when it is pulled low (<0.9 V).

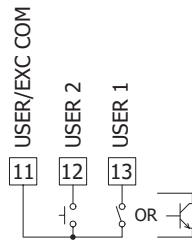

### Sourcing Logic

When the parameter is programmed to High, check with device GUI option. The user inputs of the controller are internally pulled down to 0 V with 20 KΩ resistance. The input is active when a voltage greater than 2.4 VDC is applied.

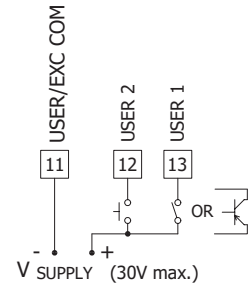

## ON-BOARD DUAL SSR WIRING

The SSR outputs require meter configuration to address their functionality. The drawings below illustrate the wiring for each option.

### Sinking Mode

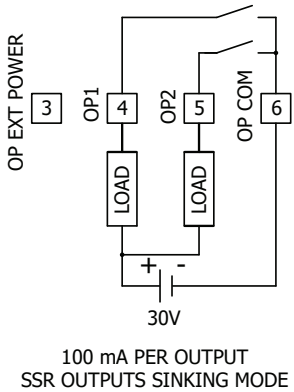

### Sourcing Mode

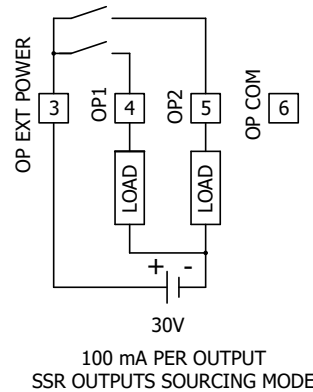

## RS485/MODBUS

### RS485 2-WIRE CONNECTIONS

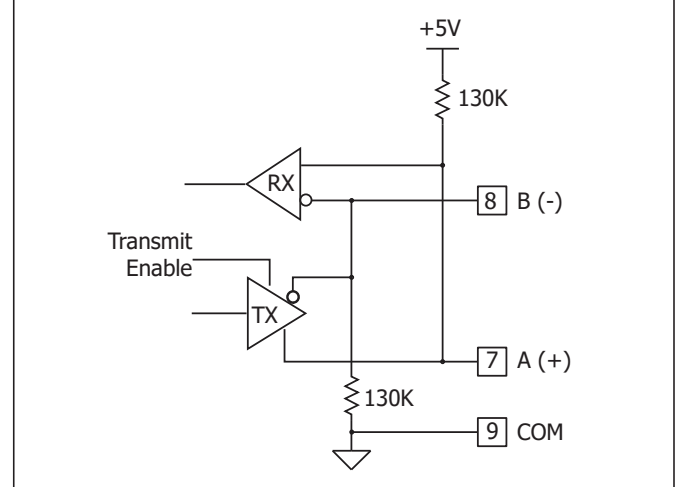

## CONFIGURING A PM-50

Various options are available to configure your PM-50 so you can choose the one that fits your requirement.

### Programming Wizard

On initial power up a Programming Wizard will offer assistance. Proceeding with the Wizard will help with the basic configuration including screen set-up, selecting the input and programming the output. After completion your device will display the items you selected. Additional capabilities can be accessed via the Programming App, Web Server, or manually entering the programming.

### Web Interface

To configure the device for web access, login as Admin and follow the below steps to setup Wi-Fi:

1. Go to System → Network Configuration → Wi-Fi Configuration
2. Enable Wi-Fi as "ON" and select the right arrow
3. From here, make your Wi-Fi configuration selections based on your connection setup.

### App Connectivity

Programming and monitoring of the device can be done via an App. Go to the App Store and search for PM50 by Red Lion. Install the app on your smart device. With Wi-Fi enabled, monitoring and controlling of the device can be done through the app. Now programming the device is as easy as making some selections and downloading to the device.

## INSERTION/REMOVAL OF THE microSD CARD

The microSD Card can be used to flash new firmware on PM-50 by placing an image file on the formatted microSD card. It can also be used to import previous configuration through import/export configuration menu. The card is then inserted into the PM-50 slot located next to the terminals on the bottom side of the unit. Refer to the User manual for more information on the proper names and locations of the files.

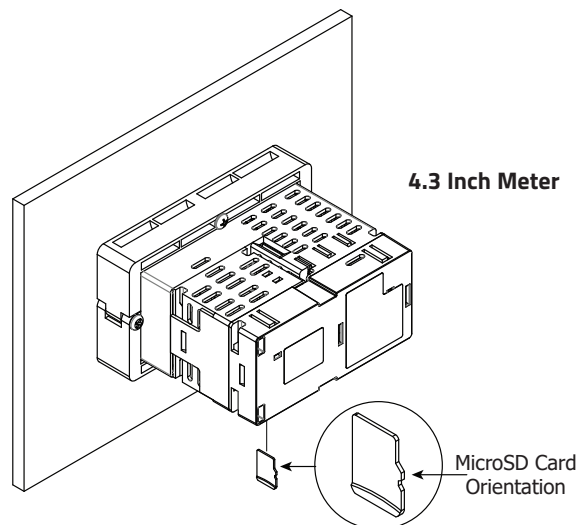

After inserting the microSD card into the unit, navigate to the Device/Misc. Configuration/Firmware Upload screen on the PM-50 to upload the latest firmware version.

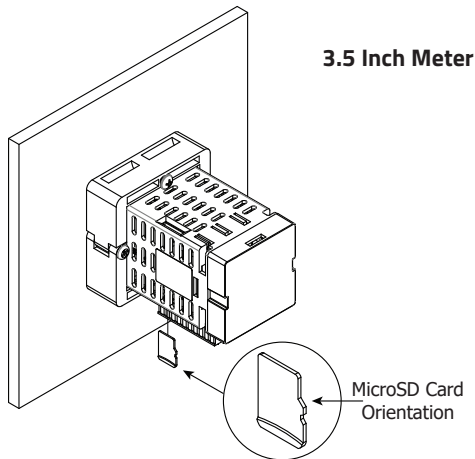

### RED LION CONTROLS TECHNICAL SUPPORT

If for any reason you have trouble operating, connecting, or simply have questions concerning your new product, contact Red Lion's technical support.

Support: [support.redlion.net](http://support.redlion.net)  
 Website: [www.redlion.net](http://www.redlion.net)  
 Inside US: +1 (877) 432-9908  
 Outside US: +1 (717) 767-6511

Red Lion Controls, Inc.  
 20 Willow Springs Circle York, PA 17406

### COPYRIGHT

©2021-202x Red Lion Controls, Inc. All rights reserved. Red Lion and the Red Lion logo are trademarks of Red Lion Controls, Inc. All other company and product names are trademarks of their respective owners.

### TRADEMARK ACKNOWLEDGMENTS

Wi-Fi® and the Wi-Fi logo are registered trademarks of Wi-Fi Alliance.

**See appropriate document for instructions on module installation and wiring support.**

### ORDERING INFORMATION

DESCRIPTION	PART NUMBER
4.3" Analog Input Graphical Panel Meter	PM500A0400800F00
3.5" Analog Input Graphical Panel Meter	PM500A0301600F00

### Accessories

TYPE	DESCRIPTION	PART NUMBER
Modules	RS232 Serial Communications Module	PMM000CM23200000
	Ethernet Communications Module	PMM000CMEN000000
	Analog Output Module	PMM000IOAN000000
	Dual Setpoint Relay Output Module	PMM000IORL200000
	Quad Setpoint Relay Output Module	PMM000IORL400000
	AC to DC Power Module	PMM000PWACP00000
Misc.	Replacement Rear Cover/Bus Board with Spacer Module (4.3" model only)	PMA000CP00800000
	Conversion Panel 92 mm x 75 mm to 1/8 DIN	PMA000MK00800000
	Conversion Panel 68 mm x 68 mm to 1/16 DIN	PMA000MK01600000
	Replacement Module Lock Pins	PMA000MKLP000000
	4.3" Protective Screen Overlay	PMA000SP00800000
	3.5" Protective Screen Overlay	PMA000SP01600000
	MicroSD Card	SD032G00

### LIMITED WARRANTY

(a) Red Lion Controls Inc. (the "Company") warrants that all Products shall be free from defects in material and workmanship under normal use for the period of time provided in "Statement of Warranty Periods" (available at [www.redlion.net](http://www.redlion.net)) current at the time of shipment of the Products (the "Warranty Period"). **EXCEPT FOR THE ABOVE-STATED WARRANTY, COMPANY MAKES NO WARRANTY WHATSOEVER WITH RESPECT TO THE PRODUCTS, INCLUDING ANY (A) WARRANTY OF MERCHANTABILITY; (B) WARRANTY OF FITNESS FOR A PARTICULAR PURPOSE; OR (C) WARRANTY AGAINST INFRINGEMENT OF INTELLECTUAL PROPERTY RIGHTS OF A THIRD PARTY; WHETHER EXPRESS OR IMPLIED BY LAW, COURSE OF DEALING, COURSE OF PERFORMANCE, USAGE OF TRADE OR OTHERWISE.** Customer shall be responsible for determining that a Product is suitable for Customer's use and that such use complies with any applicable local, state or federal law.

(b) The Company shall not be liable for a breach of the warranty set forth in paragraph (a) if (i) the defect is a result of Customer's failure to store, install, commission or maintain the Product according to specifications; (ii) Customer alters or repairs such Product without the prior written consent of Company.

(c) Subject to paragraph (b), with respect to any such Product during the Warranty Period, Company shall, in its sole discretion, either (i) repair or replace the Product; or (ii) credit or refund the price of Product provided that, if Company so requests, Customer shall, at Company's expense, return such Product to Company.

(d) **THE REMEDIES SET FORTH IN PARAGRAPH (c) SHALL BE THE CUSTOMER'S SOLE AND EXCLUSIVE REMEDY AND COMPANY'S ENTIRE LIABILITY FOR ANY BREACH OF THE LIMITED WARRANTY SET FORTH IN PARAGRAPH (a). BY INSTALLING THIS PRODUCT, YOU AGREE TO THE TERMS OF THIS WARRANTY, AS WELL AS ALL OTHER DISCLAIMERS AND WARRANTIES IN THIS DOCUMENT.**