

THIS DRAWING IS UNPUBLISHED. RELEASED FOR PUBLICATION
 © COPYRIGHT BY TYCO ELECTRONICS CORPORATION. ALL RIGHTS RESERVED.

LOC		DIST		REVISIONS			
P	LTR	DESCRIPTION		DATE	DWN	APVD	
	V	REVISED PER ECO-08-025671		16OCT08	HMR	JO	

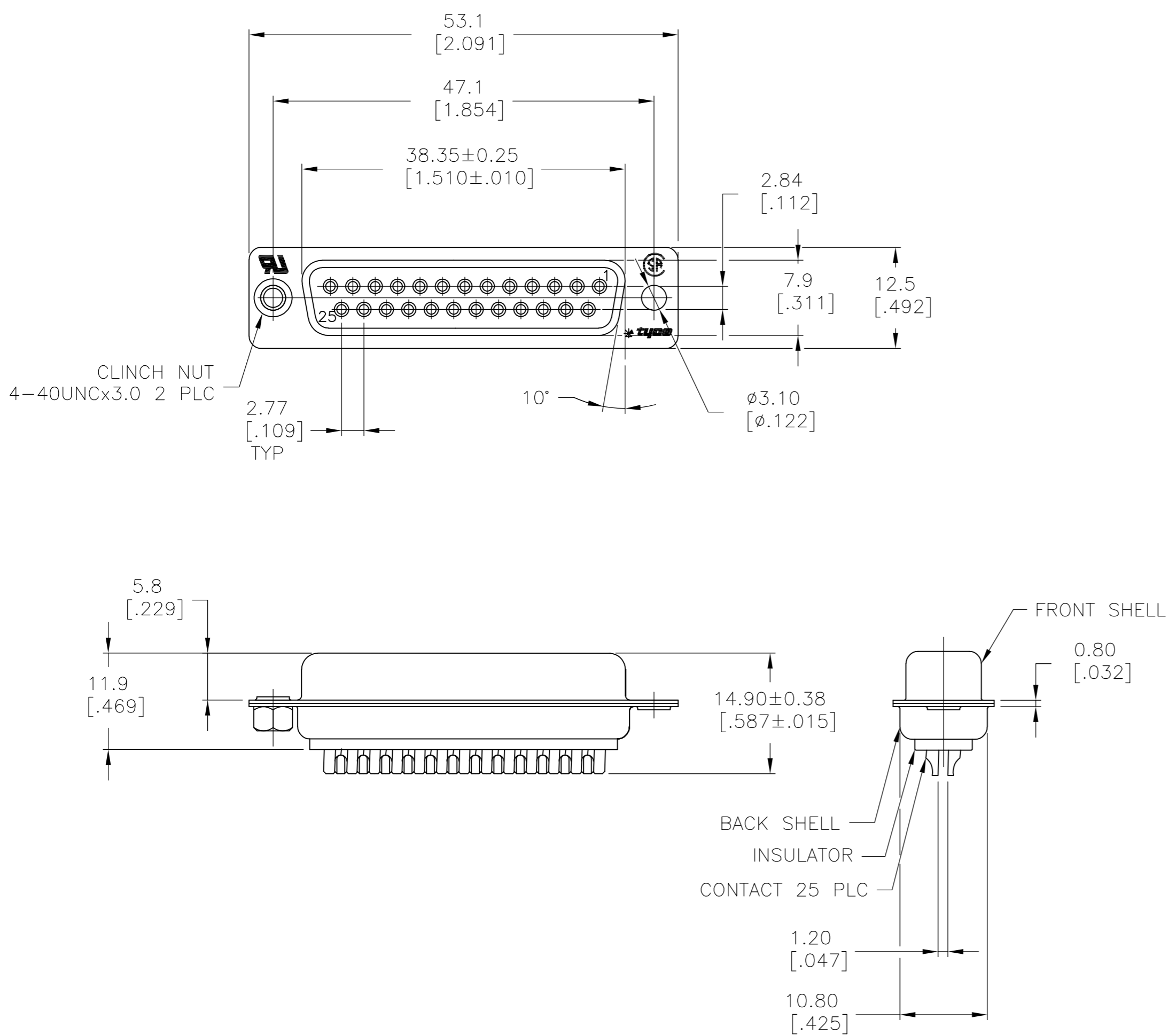

- 1 MATERIAL:
 FRONT INSULATOR: PBT, 30 %GF, UL94V-0, BLACK COLOR
 BACK INSULATOR: PBT, 30 %GF, UL94V-0, BLACK COLOR
 CONTACT: BRASS
 FRONT SHELL: STEEL
 BACK SHELL: STEEL
 CLINCH NUTS: BRASS
- 2 FINISH:
 CONTACT: GOLD PLATING 0.00002[.0000008] MIN ON CONTACT AREA 0.00229 [.000090] MIN TIN-LEAD PLATING ALL OVER 0.00127[.000050] MIN NICKEL
- 3 CONTACT: GOLD PLATING 0.00076[.000030] MIN ON CONTACT AREA 0.00229 [.000090] MIN TIN-LEAD PLATING ALL OVER 0.00127[.000050] MIN NICKEL
- 4 SHELL: TIN 0.0241[.000095] MIN FULL SHELL
- 5 SHELL: BLUE ZINC: 0.00508[.000200] - 0.00762[.000300] OVER ENTIRE SHELL
- 6 CONTACT: GOLD PLATING 0.00002[.0000008] MIN ON CONTACT AREA 0.00229 [.000090] MIN TIN-COPPER PLATING ALL OVER 0.00127[.000050] MIN NICKEL
- 7 CLINCH NUTS: NICKEL PLATING .00305-.00508[.000120-.000200]
- 8 SPECIFICATION
 ELECTRICAL CHARACTERISTICS: CURRENT RATING: 3 AMPERES
 DIELECTRIC WITHSTANDING VOLTAGE: AC 1000V r.m.s
 INSULATION RESISTANCE: 5000 MEGOHMS MINIMUM AT DC 500V
 CONTACT RESISTANCE: 10 MILLIOHMS MAXIMUM.
- 9 ROHS 2002/95/EC COMPLIANT
- 10 RECEPTACLE ASSEMBLY MATES WITH ANY 25 POSITION PLUG IN AMPLIMITE SERIES
- 11 SOLDER CUP WILL ACCOMMODATE 20 MAX AWG WIRE.
- 12 CONTACT: GOLD PLATING 0.00076[.000030] MIN ON CONTACT AREA 0.00229[.000090] MIN TIN-COPPER ALL OVER 0.00127[.000050] MIN NICKEL PLATING

9	STANDARD	NO	12	5	5-747913-6		
9	STANDARD	NO	6	5	5-747913-4		
9	STANDARD	YES	6	4	5-747913-9		
9	STANDARD	NO	12	4	5-747913-5		
9	STANDARD	NO	6	4	5-747913-2		
SUPERSEDED TO 5-747913-9		STANDARD	YES	2	4	747913-9	
SUPERSEDED TO 5-747913-2		9	STANDARD	NO	6	4	747913-8
SUPERSEDED TO 5-747913-6		STANDARD	NO	2	5	747913-6	
SUPERSEDED TO 5-747913-5		STANDARD	NO	3	4	747913-5	
SUPERSEDED TO 5-747913-4		STANDARD	NO	2	5	747913-4	
SUPERSEDED TO 5-747913-2		STANDARD	NO	2	4	747913-2	
		PACKAGING TYPE	7	CLINCH NUTS	CONTACTS	SHELLS	PART NO.

THIS DRAWING IS A CONTROLLED DOCUMENT.		DWN	M.BINNER	04MAR03	Tyco Electronics Corporation Harrisburg, PA 17105-3608
DIMENSIONS: mm [INCHES]		CHK	R.BENDORF	05MAR03	
TOLERANCES UNLESS OTHERWISE SPECIFIED:		APVD	R.BENDORF	05MAR03	
0 PLC ± - 1 PLC ± 0.25 2 PLC ± 0.13 3 PLC ± 0.05 4 PLC ± - ANGLES ± 4°		PRODUCT SPEC	NAME		
MATERIAL		FINISH	SEE TABLE		RECEPTACLE ASSEMBLY, SOLDER CUP, SIZE 3, 25 POSN, HD-20, AMPLIMITE
1		CUSTOMER DRAWING		WEIGHT	-
		SCALE		2:1	SHEET
				1	OF 1
				REV	V

747913

A