

Plexo socket outlets 2 P + E Franco-Belgian standard

Cat. Nos. : 695 51/52/53 - 696 21/22
697 31 - 698 31/70

CONTENTS

Page

1. Technical data	1
2. Range	1
3. Preparation	1-2
4. Overall dimensions	3
5. General characteristics	3/4
6. Cleaning	4
7. Special uses	4
8. Equipment and accessories	5
9. Conformities and approvals	5

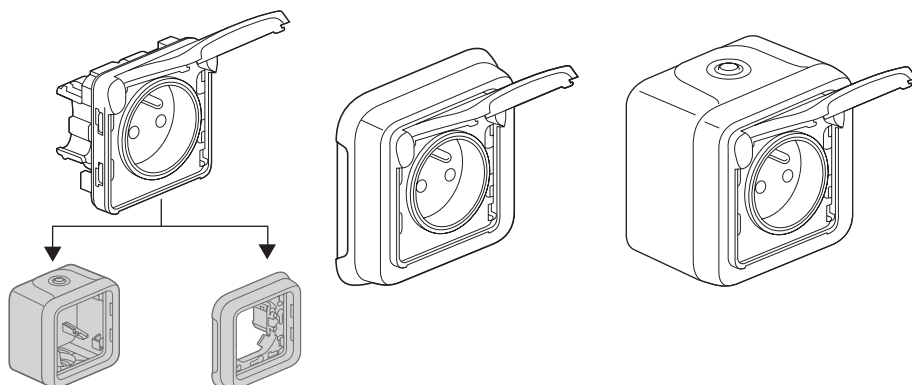

1. TECHNICAL DATA

Weatherproof wiring devices system intended for residential and professional technical premises (garages, cellars, car parks, workshops and industrial kitchens, etc.) as well as outdoor environments (patios, terraces, gardens, camping sites, etc.).

Socket outlets 16 A 250 V~ to the French and Belgian standard, with protective shutters, accept common 2P and 2P+E plugs to the French and Belgian standard.

Tamperproof version to meet specific uses (IT, special networks), with insert Cat. No. 50299.

2. RANGE

Cat. No.	2 versions : grey and white
695 xx 696 xx	Configurable
697 xx 698 xx	Surface-mounting complete Flush-mounting complete
699 xx	DIY

	Description	Marketing Cat. Nos	Characteristics	Connection	Weight
CONFIGURABLE	Socket outlet Franco-Belgian 2P+E	695 51 696 21	16 A 250 V~	Auto terminals	56 g
		695 52 696 22	16 A 250 V~	With screws	56 g
	Socket outlet Franco-Belgian 2P+E tamperproof	695 53	16 A 250 V~	Auto terminals	56 g
COMPLETE	Socket outlet Franco-Belgian 2P+E	697 31	16 A 250 V~	Auto terminals	140 g
		698 31 698 70	16 A 250 V~	Auto terminals	100 g

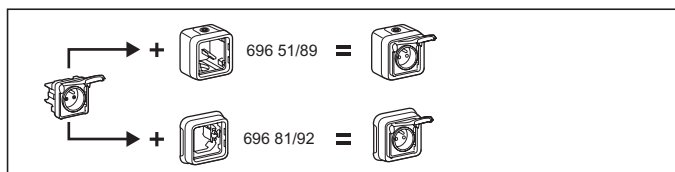

3. PREPARATION

3.1 Surface-mounting

- by screwing the base box onto the support using 2 screws
Ø 3-4 mm max.

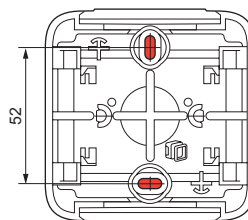

- to replace the former Plexo 55 series

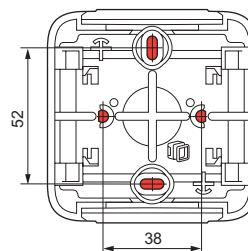

3.2 Flush-mounting

- by screwing onto a flush-mounting box

- by claws onto a flush-mounting box

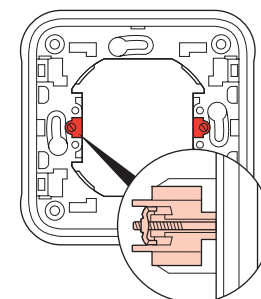
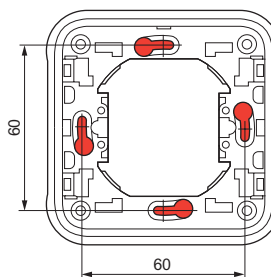

Plexo socket outlets 2 P + E Franco-Belgian standard

Cat. Nos. : 695 51/52/53 - 696 21/22
697 31 - 698 31/70

3. PREPARATION (continued)

- By face plate using 4 screws \varnothing 4 mm
- Piercing of support material for diameter 60-70 mm using cylinder saw or punch.

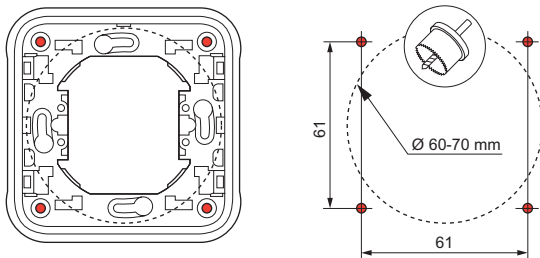

3.3 Connection to conductors

- Automatic terminal mechanisms

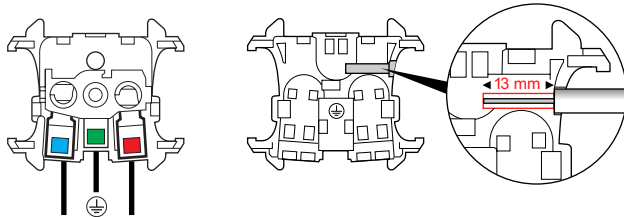

The stripping length required is 13 mm. The correct stripping length can be checked against the gauge on the rear of the base. Terminal capacity is 1.5 mm² - 2.5 mm² (1 or 2 conductors).

- Screw terminal mechanisms

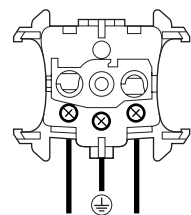

Pillar terminals supplied open, with screws backed off and locked
Min. capacity : 1 x 1.5 mm²
Max. capacity : 3 x 2.5 mm² or 2 x 4 mm²
Max. tightening torque : 0.8 N/m
Usable screwdrivers : flat blade 3.5-5 mm or Phillips No.1

3.4 Connection to conduits

Type of conduits :

- IRL : formerly IRO, insulating rigid smooth
 - ICA : insulating bendable corrugated
 - ICTA : insulating, bendable, transversally elastic, corrugated
 - ICTL : insulating, bendable, transversally elastic, smooth
- } \varnothing 16 - 25 mm

Cables (examples) :

- rigid conductors : U - 1000R2V 3G2.5
- flexible conductors : H07 RN - F 3G2.5

Type of outlet glands : membrane flexible, 2 removable types.

- 1-outlet gland supplied on 1-gang box (top and bottom)
- 1-outlet gland supplied on 2 and 3-gang boxes (top)
- 2-outlet gland supplied on 2 and 3-gang boxes (bottom)

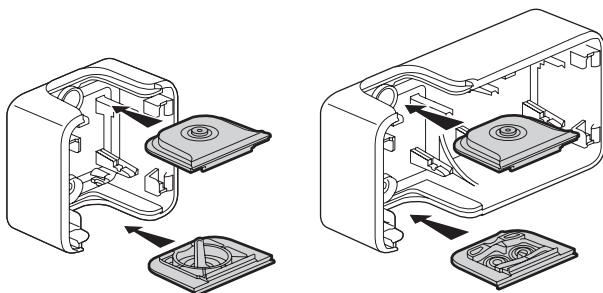

3. PREPARATION (continued)

3.4 Connection to conduits (continued)

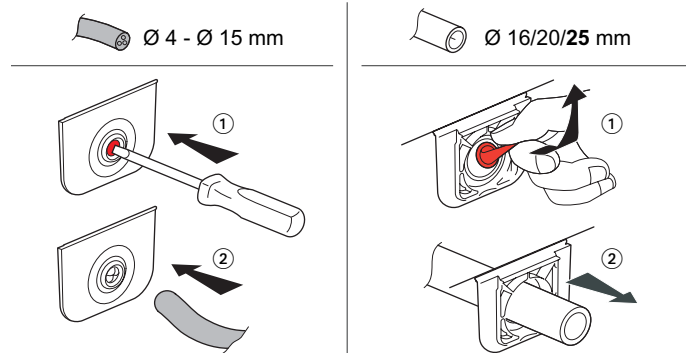

Also available as accessories :

- 695 96 1-outlet gland grey
- 695 99 2-outlet gland grey
- 696 46 1-outlet gland white
- 696 49 2-outlet gland white

3.5 Assembly

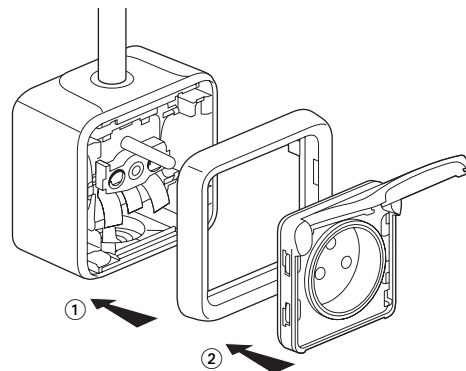

The front part (cover) is IP55 locked onto the box using the four 1/4 turn screws.

The direction of rotation of each 1/4 turn screw is marked on the cover.

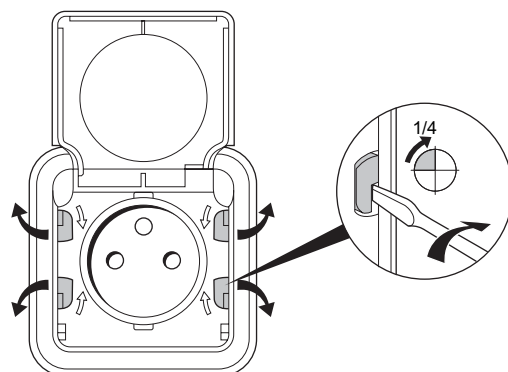

Plexo socket outlets 2 P + E Franco-Belgian standard

Cat. Nos. : 695 51/52/53 - 696 21/22
697 31 - 698 31/70

4. OVERALL DIMENSIONS

Configurable

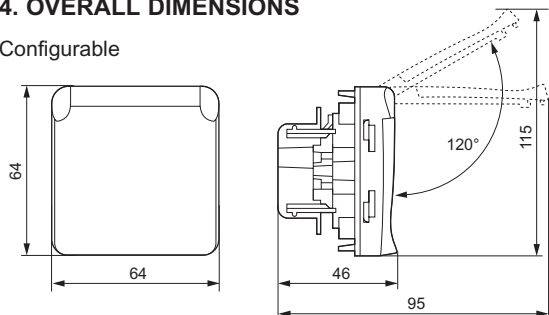

Surface-mounting

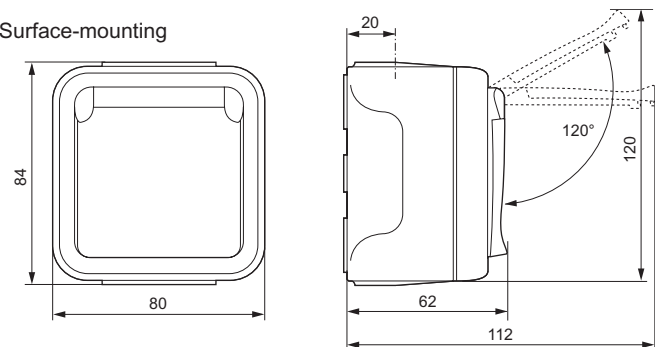

Flush-mounting

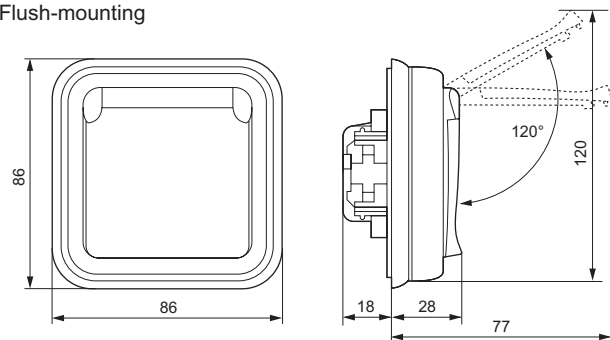

5. GENERAL CHARACTERISTICS

5.1 Mechanical characteristics

Protection index :

- IP 55 IK 07, shutter closed

5.2 Material characteristics

Materials

Box, support : PP reinforced polypropylene

Plate, shutter : ABS (Acrylonitrile Butadiene Styrene)

Outlet gland : PP + SEBS (Styrene Ethylene Butadiene Styrene)

Mechanism : PC (Polycarbonate)

5.3 Resistance to chemicals

Chemical	Behaviour
Acetone	-
Acetic acid 10 %	+
Acetic acid 30 %	+
Aminosulphonic acid	+
Boric acid *	+
Bromhydric acid 47 %	-
Hydrochloric acid *	+
Chromic acid	+
Citric acid *	+
Hydrofluoric acid *	-
Formic acid	-
Lactic acid *	+
Linoleic acid	-
Maleic acid	+
Nitric acid 30 %	-
Nitric acid 50 %	-

Perchloric acid 10 %	+
Phenol-sulphonic acid	-
Phosphoric acid *	-
Sulphuric acid	+
Tannic acid *	-
Tartaric acid *	+
Ethyl alcohol	+
Isopropyl alcohol	+
Methanol	-
Phenylethyl alcohol 100 %	-
Ammonia	+
Electroplating baths :	
- Bright silver bath	+
- Bright cadmium bath	+
- Chrome bath (50° C)	+
- Copper bath (with potassium cyanide)	+
- Copper bath (acid)	+
- Pickling bath with chemical copper	+
- Brass bath	+
- Bright nickel bath	+
Barium	
- Barium chloride *	+
- Barium hydroxide *	+
- Barium nitrate *	-
Benzene	-
Beer	+
Bleaching powder *	+
Cobalt chloride *	-
Copper chloride *	-
Ferrous chloride *	-
Manganese chloride	-
Mercury chloride *	-
Methylene chloride	-
Chlorine water (wet gaseous chlorine)	-
Sea water	+
Fertilizer	+
Epichlorhydrine	-
Heavy gasoline	-
White gasoline	-
Turpentine	-
Essential oils	+
Linseed oil	+
Lubricating oil	+
Machinery oil	+
Mineral oil	+
Paraffin oil	+
Fish oil	+
Castor oil	+
Silicon oil	+
Humus	+
Aqueous hydrogen sulphide	+
Sodium hypochlorite 10 %	+
Fruit juice	+
Milk	+
Chlorinated detergent	+
Margarine	+
Black oil	+
Mercury	+
Methyl methacrylate	-
Silver nitrate *	+
Cobalt nitrate *	+
Manganese nitrate *	+
Mercury nitrate *	+
Nickel nitrate *	+
Lead nitrate *	+
Petroleum, petroleum ether	-
Silicate (potassium, sodium)	+
Beet syrup	+
Sodium	
- Sodium acetate *	+
- Sodium bromate *	+
- Sodium chloride * (salt)	+

Plexo socket outlets 2 P + E Franco-Belgian standard

Cat. Nos. : 695 51/52/53 - 696 21/22
697 31 - 698 31/70

5. GENERAL CHARACTERISTICS (continued)

5.3 Resistance to chemicals (continued)

Caustic soda ≤ 40 %	+
Styrene monomer	-
Sugar	+
Trichlorethylene	-
Urine	+
Wine	+

* all concentrations in aqueous solution

Interpretation : **+ resists** **- instability**

This information is given for guidance, and does not therefore engage our liability.
Consult us for any special use.

5.4 UV resistance

No noticeable change following a 7-day test with irradiance of 550 W/m₂ (colorimetric measurement according to Lab method).

5.5 Resistance to salt spray : 7 days (168 h)

5.6 Electrical characteristics

- Self-extinguishing to IEC 60695-2-11 :
- components (or parts) required to hold live parts in place : 850°C
- components (or parts) not required to hold live parts in place : 650°C
- Voltage - Current - Frequency
- 16 A 250 V~ 50 Hz according to NF C 61-314, NBN C 61-112 and IEC 60884-1.

5.7 Climatic characteristics

Storage and use temperature : - 25°C to + 60°C

6. CLEANING

Surface cleaning with dry cloth or cloth dipped in soapy water. Do not use acetone, tar remover or trichloroethylene.

Important : a test should be carried out before using any specific cleaners.

7. SPECIAL USES

Installations with profile.

The Plexo profile distribution system provides :

- Distribution, protection and branching of different wires and cables in an electrical installation.
- A profile, and finishing and routing accessories (profile seal, universal weatherproof junction, flat angle, internal angle, external angle, tee, yoke).
- A new solution for installing weatherproof surface-mounting devices in technical residential and more occasionally technical commercial environments.
- Optimum reliability and safety through compliance with standard NFC 68-104 (IP 42, IK 07)

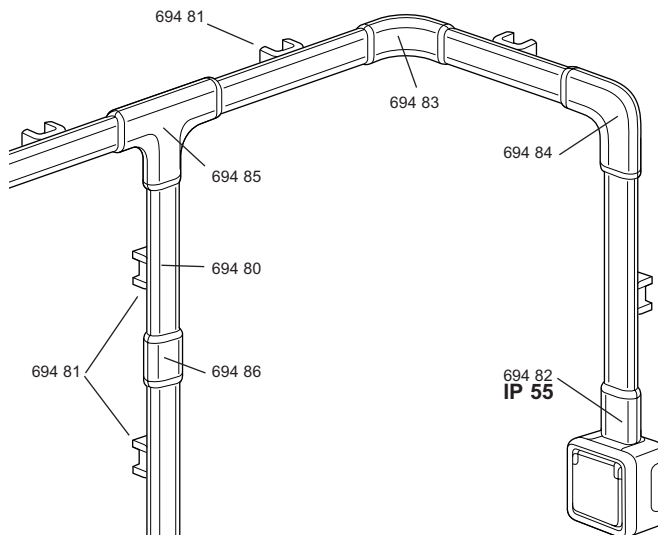







Cat. Nos.	Description
694 80	Plexo profile, length 2.00 m, capacity equivalent to IRL Ø 25 mm
694 81	Plexo profile yoke
694 82	Universal weatherproof junction IP55
694 83	Plexo profile internal/external angle
694 84	Plexo profile flat angle
694 85	Plexo profile tee
694 86	Plexo universal joint

- Refer to the specific technical data sheet for the Plexo profile : F00386FR/00.

Plexo socket outlets 2 P + E Franco-Belgian standard

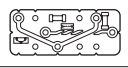

Cat. Nos. : 695 51/52/53 - 696 21/22
697 31 - 698 31/70

8. EQUIPMENT AND ACCESSORIES

Description	Uses	Cat. No.	Colour
 <p>Tamperproof insert</p>	For sockets Cat. No. 995 53 and 696 23. Fixes directly on the 2 P+E plug of the device intended to be connected to the tamperproof socket.	502 99	-
  <p>1-outlet gland 2-outlet gland</p>	For making an aesthetic junction between boxes and cables up to Ø 16 mm inclusive	695 96 696 46 695 99 696 49	Grey White Grey White
 <p>Plotting template</p>	For rapidly finding the fixing distances of all the boxes	695 97	-
 <p>Set of 4 caps</p>	For blanking the fixing holes at the box base	695 98	Grey
<p>Multi-cable gland</p>	(PG) Ø 7 - 14 mm (ISO) Ø 9 - 14 mm	696 53 696 54	
  <p>Standard claw Long claw</p>	Mounts on all flush-mounting 1-gang supports by simple clipping	849 00 849 01	- -
 <p>Tapping terminal strip</p>	Direct connection after simple stripping of rigid conductors Terminal capacity : 0.75 - 2.5 mm ²	343 22	

9. CONFORMITIES AND APPROVALS

- Products produced in compliance with standards :
 - France NF C 61-314
 - Belgium NBN C 61-112
 - International IEC 60884-1
- NF USE approval according to NF C 61-314
- Conform with NF C 15-100 (child protection by shutter system)

Quality marks	Standards	Certificate No.
	NF C 61-314	21/03/2007
	CEI 60884-1	In process
	CEI 60884-1	In process