

AS85049/19 Straight EMI/RFI Non-Environmental Backshell



AS85049

CONNECTOR DESIGNATOR:	
H	MIL-DTL-38999 Series III and IV EN3645

Finish
<i>N = Electroless Nickel</i>
<i>W = Cadmium, Olive Drab</i>
<i>X = Nickel Fluorocarbon Polymer</i>
<i>Z = Zinc Nickel</i>

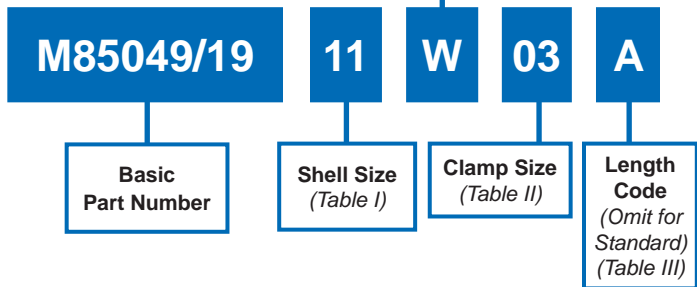

B

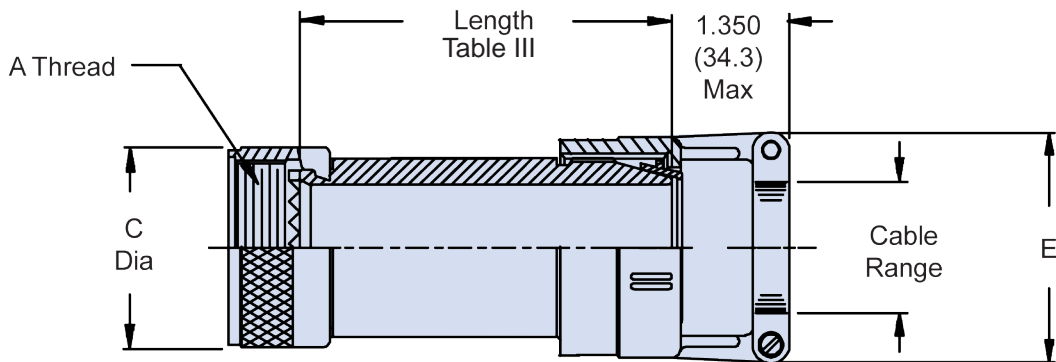

APPLICATION NOTES
1. For complete dimensions see the applicable Military Specification.
2. Metric dimensions (mm) are in parentheses.
3. Cable Range is defined as the accommodation range for the wire bundle or cable. Dimensions shown are not intended for inspection criteria.

Dimensions in inches (millimeters) and are subject to change without notice.

© 2013 Glenair, Inc.

U.S. CAGE Code 06324

Printed in U.S.A.



AS85049/19 Straight EMI/RFI Non-Environmental Backshell

B

TABLE I: Shell Size and Clamp Size

Shell Size	Clamp Size		A Thread Class 6H	C Dia Max
	Min	Max		
9	01	02	M12 X 1 - 6H	.750 (19.1)
11	01	03	M15 X 1 - 6H	.850 (21.6)
13	02	04	M18 X 1 - 6H	1.000 (25.4)
15	02	05	M22 X 1 - 6H	1.100 (27.9)
17	02	06	M25 X 1 - 6H	1.250 (31.8)
19	03	07	M28 X 1 - 6H	1.400 (35.6)
21	03	08	M31 X 1 - 6H	1.500 (38.1)
23	03	09	M34 X 1 - 6H	1.650 (41.9)
25	04	10	M37 X 1 - 6H	1.700 (43.2)

TABLE II: Cable Range and Dimensions

Clamp Size	Cable Range		E Max
	Min	Max	
01	.062 (1.6)	.125 (3.2)	.800 (20.3)
02	.125 (3.2)	.250 (6.4)	1.000 (25.4)
03	.250 (6.4)	.375 (9.5)	1.100 (27.9)
04	.312 (7.9)	.500 (12.7)	1.200 (30.5)
05	.437 (11.1)	.625 (15.9)	1.250 (31.8)
06	.562 (14.3)	.750 (19.1)	1.400 (35.6)
07	.687 (17.4)	.875 (22.2)	1.500 (38.1)
08	.812 (20.6)	1.000 (25.4)	1.650 (41.9)
09	.937 (23.8)	1.125 (28.6)	1.750 (44.5)
10	1.062 (27.0)	1.250 (31.8)	1.900 (48.3)

TABLE III: Length Code

Length Code	Available Shell Sizes	Length
Std.	9 - 25	1.500 (38.1)
A	9 - 25	2.500 (63.5)
B	15 - 25	3.500 (88.9)
C	21 - 25	4.500 (114.3)

Dimensions in inches (millimeters) and are subject to change without notice.