

# 62EM1-Programmable 62mm Electrical Series

## Optimized for Silicon Carbide (SiC) MOSFET Modules

### Overview

The AgileSwitch 62EM1-62mm Electrical driver provides monitoring and fault reporting information to enable better control and analysis of SiC MOSFET-based power systems. The 62EM1 provides up to 20 Amps of peak current at an operating frequency up to 200 kHz. The driver includes isolated HI and LO Side DC/DC converters and provides 7 fault conditions that are reported as a combination of the 3 fault lines via the 20 pin control header. All AgileSwitch drivers use automotive temperature grade components and allow for modifying settings of gate resistors.

### Software Programmable Features

- Augmented Turn-Off™ (ATOff) (Patented)
- Power supply under-voltage lockout (UVLO)
- Power supply over-voltage lockout (OVLO)
- Desaturation detection settings
- Dead time
- Fault lockout settings
- Automatic Reset settings

### Key Switch Driver Features

- UL Complaint - 1200V & 1700V SiC
- Single-ended (5V, 15V) or Differential (RS-422 Compatible) logic
- Temperature Monitoring, PWM
- Isolated High Voltage Monitoring, PWM
- 2 X 10W output power
- RoHs compliant
- Configurable Gate Output Voltages
- Up to 7 Unique Fault Conditions

### Applications

- High Speed Trains/Traction
- Motor Drives
- HEV/EV
- Induction Welding, Cutting and Heating
- Solar/PV inverters
- Wind Turbines
- UPS
- Frequency Conversion

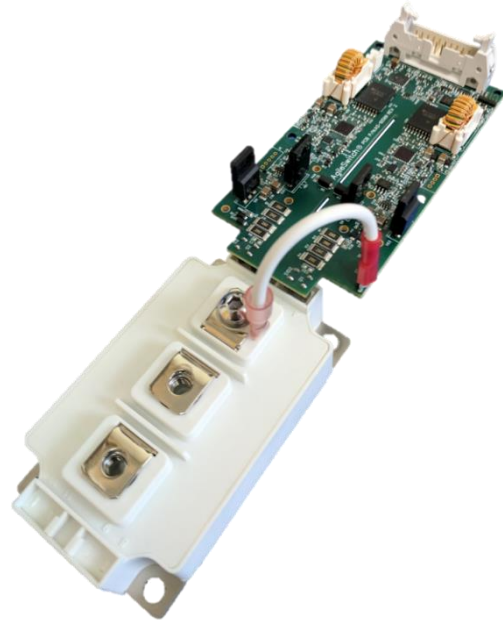

## System Overview

The basic topology of the driver is shown in Figure 1.

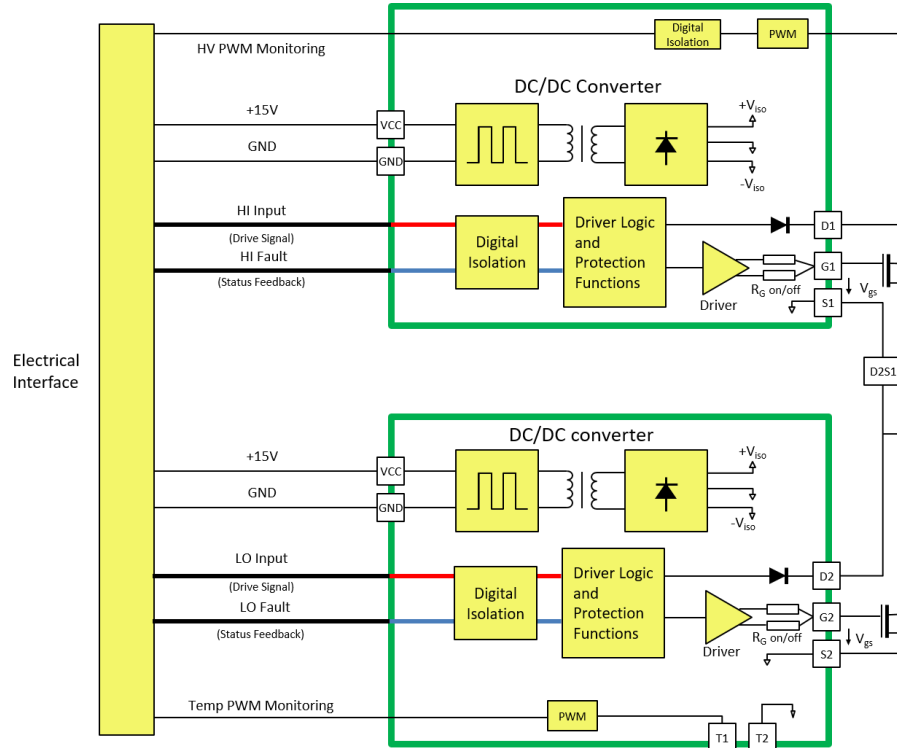

Figure 1: Basic schematic of the 62EM1-62mm Electrical Gate Driver

## Absolute Maximum Ratings

Interaction of maximum ratings is dependent on operating conditions

Parameter	Description	Min	Max	Unit
Supply Voltage	VCC to GND	0	18	V
Peak Gate Current	Note 1	-20	20	A
Input Logic Levels	To GND	-0.5	16	V
Output Power per Gate			10.0	W
Switching Frequency	Note 2		200	kHz
Isolation Voltage	Primary to Secondary VAC RMS 1 min		4500	V
Working Voltage	Primary to Secondary, Secondary to Secondary		1200/1700	V
Creepage Distance	Primary to Secondary Side	12		mm
$dV/dt^*$	Rate of change input to output	100		kV/ $\mu$ s
Operating Temperature	Ambient Operating Temperature	-40	+85	°C
Storage Temperature		-40	+90	°C

## Electrical Characteristics

Conditions:  $V_{SUP} = +15.0\text{ V}$ ,  $V_{IN\_LOGIC} = 15\text{V or }5\text{V}$ , MOSFET = CAS300M12BM2

Power Supply	Description	Min	Typ	Max	Unit
Supply Voltage	VCC to GND	14	15	16	V
Supply Current	Without Load		110		mA
Supply Current	With Load, Note 3			1250	mA
UVLO Level-HI and LO*	Primary Side low voltage detect fault level	13.5	14		V
UVLO Level-HI and LO*	Secondary Side low voltage detect fault level, Note 3	20			V
OVLO Level-HI and LO*	Primary Side high voltage detect fault level		16	16.5	V
$V_{SOFT}^*$	2-Level Turn Off, Note 3		1.5		V
$V_{softD1}^*$	DSAT 1 <sup>st</sup> Level Turn Off Voltage, Note 3		9		V
$V_{softD2}^*$	DSAT 2 <sup>nd</sup> Level Turn Off Voltage, Note 3		5		V

Signal I/O	Description	Min	Typ	Max	Unit
Input Impedance	5V - HI and LO side input		500		$\Omega$
	15V - HI and LO side input		3000		$\Omega$
	5V Differential – HI and LO side input		1000		$\Omega$
$V_{IN}$ Low	5V - Turn-off threshold			1.25	V
	15V - Turn-off threshold			4	V
$V_{IN}$ High	5V – Turn-on Threshold	3.5			V
	15V - Turn-on threshold	10			V
$V_{IN}$ (differential option)	Difference between VIN+ to VIN-	2			V
Gate Output Voltage Low	Note 3	-6		-4	V
Gate Output Voltage High	Note 3	+17		+21	V
Fault Output Voltage	Fault lines are open collect with 5mA load	0.3			V
Fault Output Current	Note 4			10	mA
Switching Frequency	Note 2			200	kHz
DC Link & Temp Monitoring	High Voltage (HV) & Temp Monitoring Output	0		5	V
DC Link & Temp Monitoring	PWM Frequency		31.5		kHz
DC Link & Temp Monitoring	Output Impedance		510 1%		$\Omega$
DC Link Voltage		880		920	V
Temperature Trip			125		$^{\circ}\text{C}$

MOSFET Short Protection	Description	Min	Typ	Max	Unit
Desat Monitor Voltage*	Between Drain and Sink of MOSFET, Note 3		8.25		V
$T_{DSAT}^*$	Activation after MOSFET Turn on		1.5		$\mu\text{s}$
Response Time after Fault				200	ns

**Note 1:** Input signal should not be activated until 20 ms after power is applied to allow on board DC-DC converter to stabilize.

**Note 2:** Actual maximum switching speed is a function of gate capacitance.

**Note 3:** SiC MOSFET dependant, conditions listed above assume CAS300M12BM2

**Note 4:** Fault lines are open collector and require a pull-up resistor, 2K $\Omega$  recommended

\* Software configurable parameter

**Temperature and High Voltage PWM Monitoring:** The AgileSwitch 62EM1 Driver provides two 31.5 kHz, 5.0V PWM output signals that monitor the thermistor temperature (non-isolated) and the DC Link Voltage(isolated) (High Side drain to Low Side source) of the SiC MOSFET power module. The PWM signals have an output impedance of 510Ω. When combined with an external low pass filter, these signals represent a real time, isolated voltage for both High Voltage and Thermistor Temperature. A Sallen-Key active low pass filter can be used with these outputs as shown below with a 2 kHz cut-off frequency. The cut-off frequency can be optimized for your application. For simplicity, a simple RC low pass filter with 100 Hz cut-off frequency can also be used.

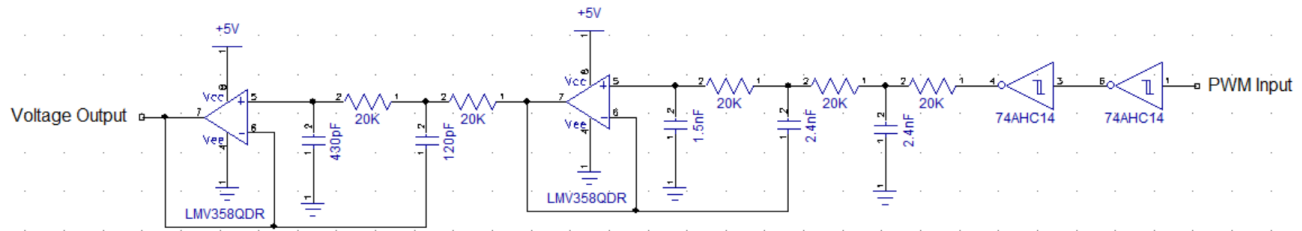

Figure 2: Example of external 2 kHz low pass filter

## Interconnects

### Controller/Power to Driver Connectors

Connector	Type	Ref	Manufacturer Part Number
Driver Board	20 Pin	J1	FCI 71918-220LF
Cable Assembly	20 Pin		FCI 71600-120LF

Recommended Cable for High Noise Environments: Flat Ribbon Cable, Twisted Pair, Shielded ([3M 1785/20 Series](#))

### Master to Slave Driver Connectors (Optional – Please specify if required, otherwise not populated)

Connector	Type	Ref	Manufacturer Part Number
Driver Board	5 Pin	J6	JST B05B-PASK-1
Cable Assembly	5 Pin		JST PAP-05V-S
Driver Board	4 Pin	J7	JST B04B-PASK-1
Cable Assembly	4 Pin		JST PAP-04V-S

### Thermistor Connector

Connector	Type	Ref	Manufacturer Part Number
Driver Board	2 Pin	J5	JST B02B-PASK-1
Cable Assembly	2 Pin		JST PAP-02V-S

Standard part is a vertical 2 pin header. Right-angle 2 pin header available upon request (P/N: JST S02B-PASK-2)

### MOSFET Terminals

Ref ID	Type	Manufacturer Part Number
G1, G2, S2, S1D2	2.8mm Quick Fit	Keystone 3534
D1*	4.8mm Quick Fit	Keystone 1285-ST

\*Recommended Mate for D1 – [Keystone 8291](#) (Female Fully Insulated Quick Fit Terminal)

\*D1 Quick Fit terminal on gate driver must be connected to the D1 terminal on the SiC MOSFET module.

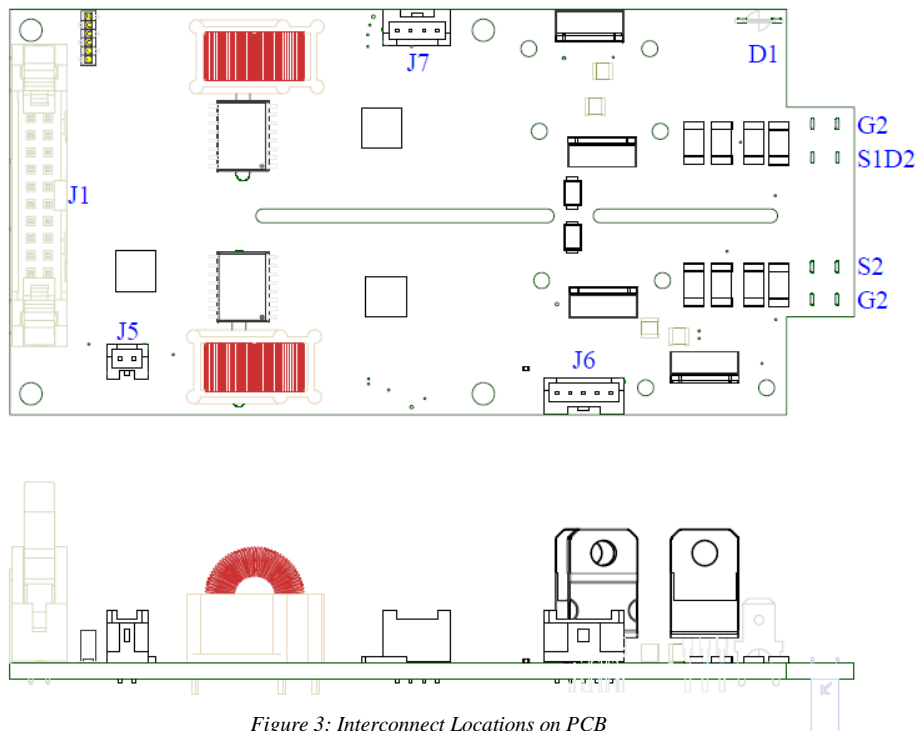

Figure 3: Interconnect Locations on PCB

**Pinout – Controller/Power to Driver Connection**

20 PIN – J1

Pin No	Signal	Pin No	Signal
1	VCC – +15V Supply Voltage	2	GND
3	VCC – +15V Supply Voltage	4	GND
5	VCC – +15V Supply Voltage	6	GND
7	VCC – +15V Supply Voltage	8	GND
9	HI-F – HI-Fault	10	GND
11	HI-D (+) HI Drive In (+)	12	HI-D (-) HI Drive In (-) or GND
13	LO-F - LO Fault	14	GND
15	LO-D (+) LO Drive In (+)	16	LO-D (-) LO Drive In (-) or GND
17	AL-F – All Faults (Low when HI-F or LO-F)	18	HV-P – Isolated High Voltage Monitoring
19	F-RS – Fault Reset (Auto Reset Optional)	20	TE-P – Temperature Monitoring

**Recommended Interface Circuitry**

Figure 3: 20 pin pinout diagram for 62EM1-62mm Electrical Gate Driver

**Pinout – Master to Slave Driver Connectors**

4 PIN – J7

Pin No	Signal
1	Positive Supply Voltage*
2	HI Drive In
3	Negative Supply Voltage*
4	GND

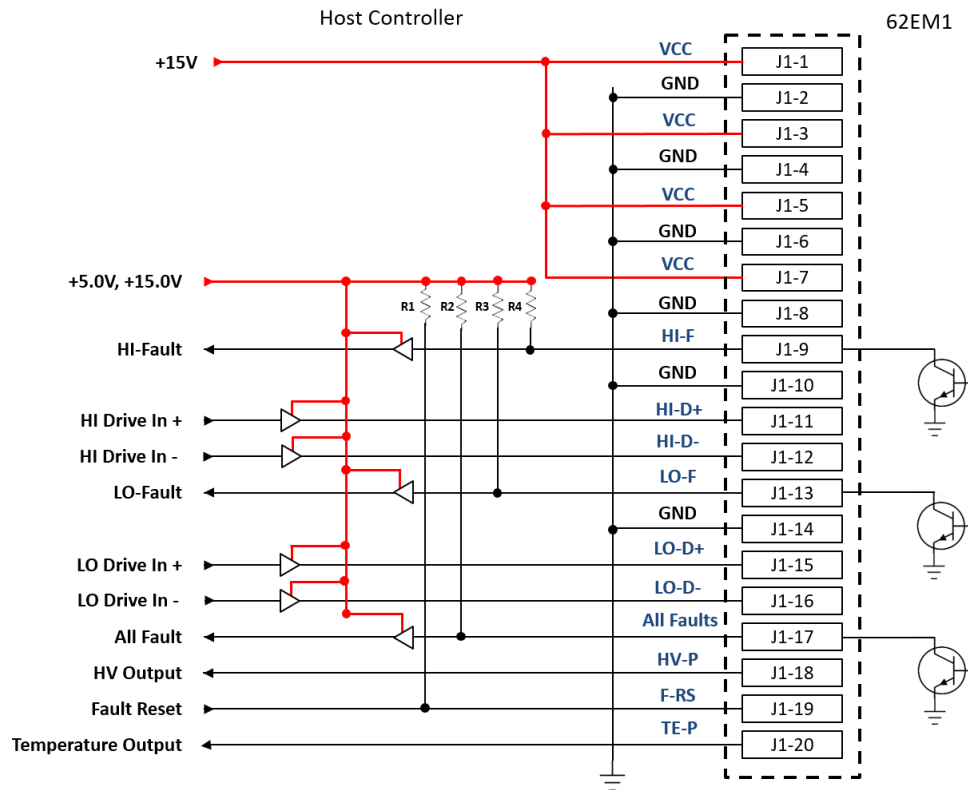
5 PIN – J6

Pin No	Signal
1	Positive Supply Voltage*
2	LO Drive In
3	Negative Supply Voltage*
4	GND
5	NC – No Connect

\*Positive and Negative Supply Voltages provided by Master Gate Driver to the Slave Gate Driver

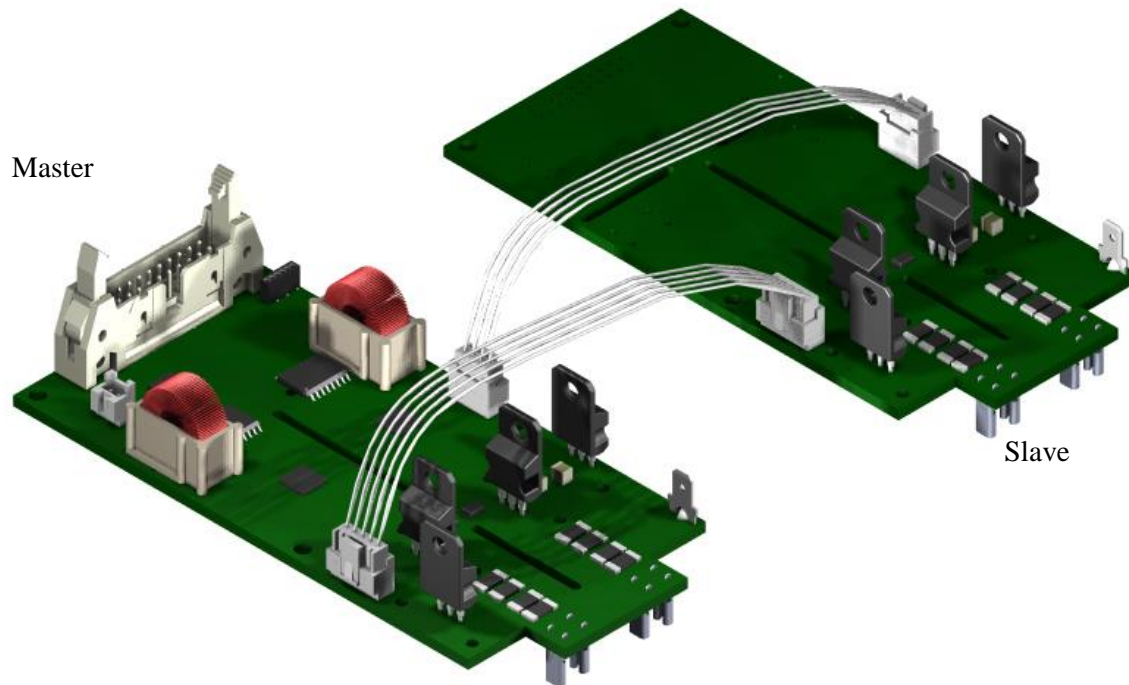
*Figure 5: Typical Master-Slave Setup*

**Buffer Schematic for Single Ended Inputs on 62EM1**

Figure 6: Input buffers on 62EM1; schematics for 5V and 15V logic

**Buffer Schematic for Differential Inputs on 62EM1**

Figure 7: Input buffer schematic - differential input

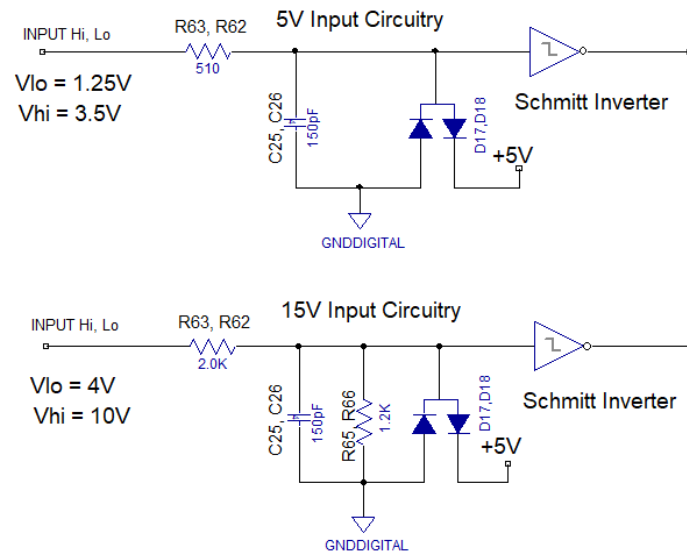

## Timing Diagrams

### Normal Operation

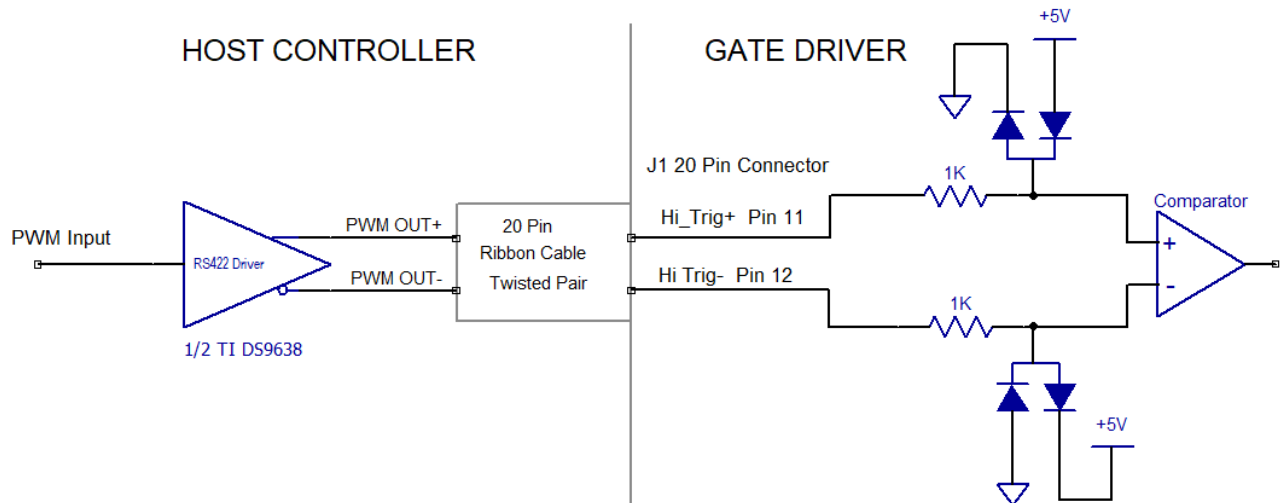
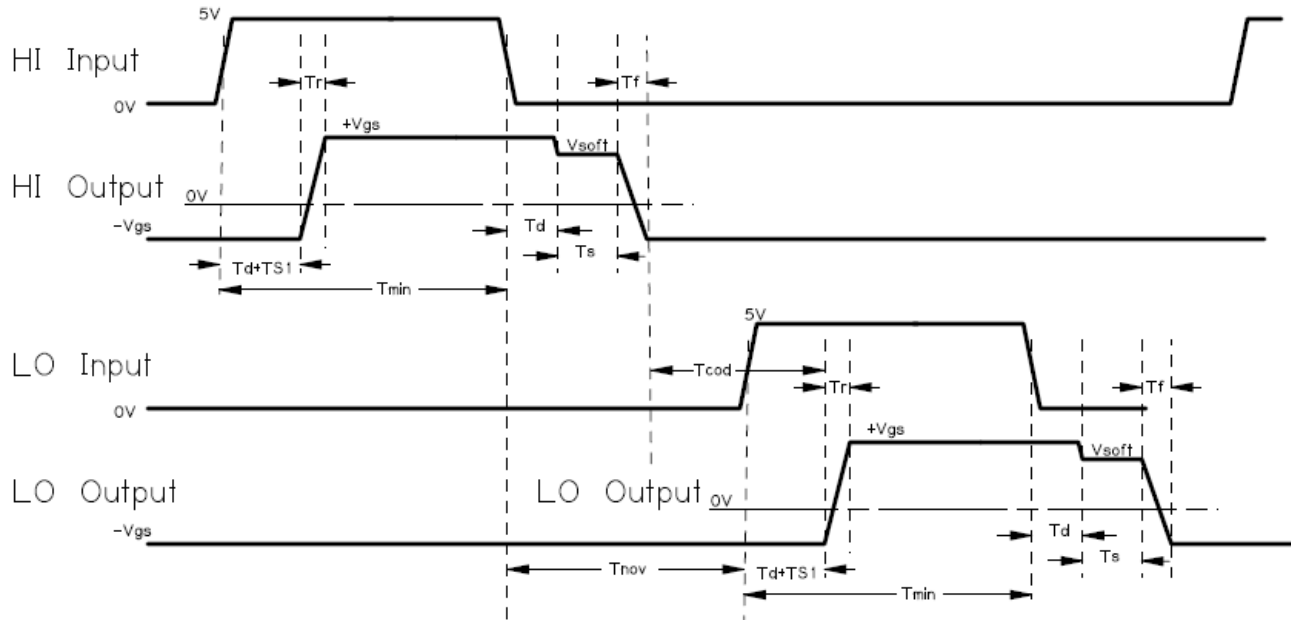

Figure 8: Signal input and output timing diagram.

### Desat Fault Timing

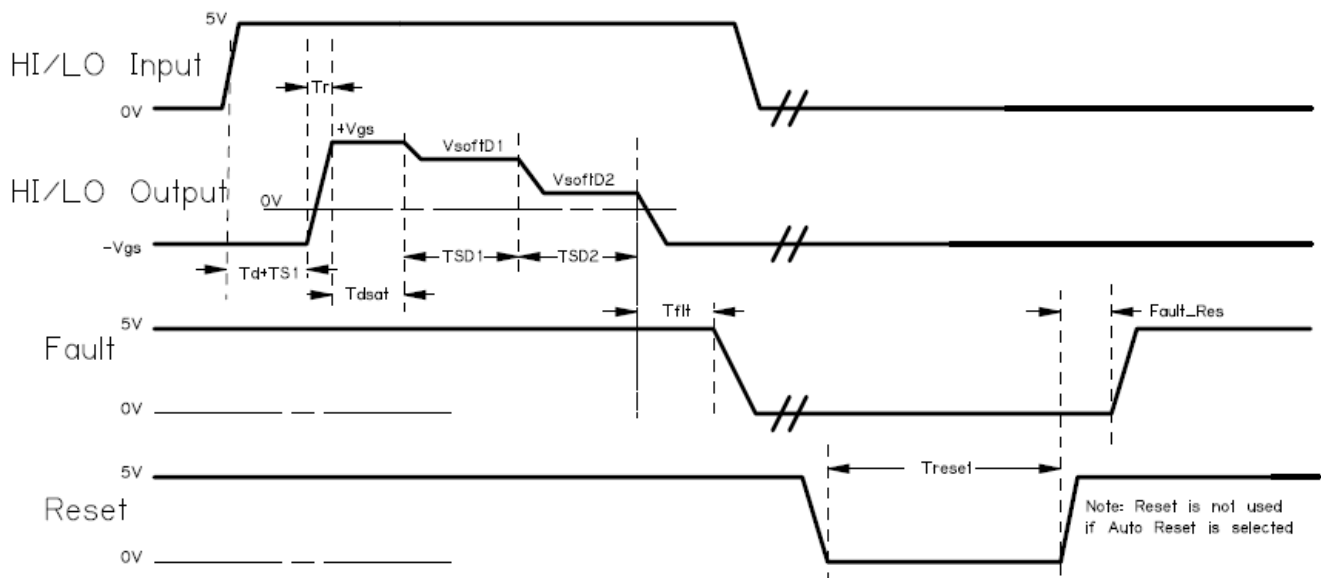

Figure 9: Signal desaturation and fault timing diagram.

**Timing Diagram Values**

 Conditions:  $V_{SUP} = +15.0\text{ V}$ ,  $V_{IN\_LOGIC} = 15\text{V or }5\text{V}$ , MOSFET = CAS300M12B2, Temp = 0 °C to 85 °C

Description	Symbol	Min	Typ	Max	Unit	Notes
Minimum Pulse Width	$T_{MIN}$	1000			ns	
Delay Time	$T_D$			250	ns	
De-Glitch Time			200		ns	Input signal de-glitch time
Rise Time	$T_R$		80		ns	Measured from 10% to 90% points on edge Measurement Point 1 – Fig. 10
Fall Time	$T_F$		90		ns	Measured from 10% to 90% points on edge Measurement Point 2 – Fig. 10
2-Level Turn-Off Time	$T_{S1}$		360		ns	Software configurable
2-Level Turn-Off Voltage	$V_{soft}$		1.5		V	Software configurable
Desaturation Time	$T_{DSAT}$	1400	1500	1600	ns	Software configurable
1 <sup>st</sup> DSAT V	$V_{soft\ D1}$		9		V	Multi-Level Turn-Off – First DSAT Step
First DSAT Time*	$T_{SD1}$		400		ns	First DSAT 2-level turn-off time
2 <sup>nd</sup> DSAT V	$V_{soft\ D2}$		5		V	Multi-Level Turn-Off – Second DSAT Step
Second DSAT Time*	$T_{SD2}$		200		ns	Second DSAT 2-level turn-off time
Fault Time Delay	$T_{FLT}$		5000		ns	
Fault Reset	$Fault\_Res$		1000		ns	
Fault Response Time	$T_{RESP}$		200		ns	
Dead Time - Input	$T_{NOV}$		1000		ns	Recommended Minimum Time between Inputs
Dead Time – Driver	$T_{cod}$	1000			ns	Minimum Time between drive signals allowed by driver, software configurable
Reset Timing	$T_{reset}$	1000			ns	Minimum Reset Time
Automatic Reset (Optional)			5		ms	Standard setting of 5 ms
Master-Slave Timing Skew				10	ns	Timing difference between Master and Slave

 \*[Note 3](#)

Figure 10: Measurement points for rise and fall time.

### Temperature Monitor

The following table describes the correlation between the Thermistor Temperature and Temperature Monitor PWM Output with 2kHz 4 pole filter. This is based on an NTC thermistor that measures 5kΩ @ 25°C. Recommended Thermistor P/N: USUR1000-502G.

Output Voltage [V]	Temperature [°C]
0.8	-3
1.6	25
2.2	41
2.8	57
3.1	67
3.3	74
3.4	80
3.7	94
4.0	108
4.1	122
4.3	138
4.4	154

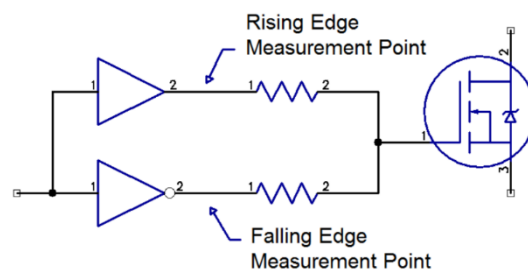
### DC Link Voltage Monitor – 1200V

The DC Link (HI Side drain to LO Side source) Monitor Output Voltage is 1% accurate from 25V to 975V. The PWM output is the ratio of the DC Link Voltage / 1000V. For example, a 500V DC Link Voltage, the PWM output will be 50%. The linear equation for the Voltage Monitor PWM Output with a 2 kHz 4 pole filter is:

$$V_{DC}[V] = 200 \times V_{monitor}$$

### DC Link Voltage Monitor – 1700V

The DC Link (HI Side drain to LO Side source) Monitor Output Voltage is 1% accurate from 50V to 1650V. The PWM output is the ratio of the DC Link Voltage / 1700V. For example, an 825V DC Link Voltage, the PWM output will be 50%. The linear equation for the Voltage Monitor PWM Output with a 2 kHz 4 pole filter is:

$$V_{DC}[V] = 340 \times V_{monitor}$$

## Generic Sample Factory Settings

AgileSwitch drivers are designed to provide safe, secure and efficient operation of the SiC MOSFET power module, as well as to provide unparalleled information on the condition of the overall system.

Generic samples are set at the factory to perform certain actions (e.g. turn off the HI side or LO side of the SiC MOSFET) and to report that a fault occurred based on performance parameters that occur outside of default ranges.

The tables below show the generic configuration.

### Performance & Interconnect Settings

Parameter	Generic Factory Setting	Value	Unit
Rgon (Turn-on Gate Resistance)	Populated	1.1	$\Omega$
Rgoff (Turn-off Gate Resistance)	Populated	1.1	$\Omega$
Desaturation Time	Enabled	1.5	$\mu$ s
Dead Time	Enabled	1	$\mu$ s
Fault Reset	Auto	5	ms
DC Link Voltage Fault	Enabled	900	V
Temperature Fault	Enabled	125	$^{\circ}$ C
UVLO Primary	Enabled	13.2	V
OVLO Primary	Enabled	16.5	V
J1 (20 pin Control/Power Header)	Populated		
J5 (2 pin Thermistor Header)	Populated		
J6 (5 pin Master/Slave Header)	Not Populated		
J7 (4 pin Master/Slave Header)	Not Populated		

### Fault and Monitoring Conditions

Fault Condition/Action	Generic Sample Default Trigger Values	Action on IGBT if Active (Default Setting)	HI Fault	LO Fault	All Faults
NO FAULTS			HIGH	HIGH	HIGH
DSAT/UVLO – HI	See Electrical Characteristics	Turn Off HI & LO Side	LOW	HIGH	LOW
DSAT/UVLO – LO	See Electrical Characteristics	Turn Off HI & LO Side	HIGH	LOW	LOW
OVLO	See Electrical Characteristics	Turn Off HI & LO Side	HIGH	HIGH	LOW
Temperature Fault	125 $^{\circ}$ C Thermistor Monitor	No Action	HIGH	HIGH	LOW
DC Link Voltage Fault	DC Link Voltage above or below setting	Turn Off HI & LO Side	HIGH	HIGH	LOW
Power On Configuration Fault*	Failure to Configure Gate drivers	Turn Off HI & LO Side	LOW	LOW	LOW

\*After power up, if all Fault lines are LOW, then either there is a real fault (UVLO/DSAT) on both the HI and LO sides or there has been a software configuration failure.

## Important Precautions



**Caution:** Handling devices with high voltages involves risk to life. It is imperative to comply with all respective precautions and safety regulations.

When installing the ribbon cable, please make sure that power is turned off. Multi-signal values are sent along this ribbon cable, thus hot swapping may cause damage to the IC components on the board.

AgileSwitch assumes that the gate drive board has been mounted on the SiC MOSFET prior to start-up testing. It is recommended that the user checks that the SiC MOSFET power modules are operating inside the Specified Operating Area (SOA) as specified by the module manufacturer including short circuit testing under very low load conditions.

## Recommended Start-Up Testing

1. Connect the driver through the 20 pin control header to your drive electronics and supply the driver with +15V.
2. Send the fault reset pin, pin 19, a low signal. Return pin 19 to a high condition. (If the driver is configured for Auto Reset, you may ignore this step.)
3. Check the gate voltage:
  - a) For the off-state, the nominal gate voltage should be -6V to -4V. (Note 3)
  - b) For the on state, it is +17 to +21V. (Note 3)
  - c) Check that the supply current of the driver is within spec with inactive trigger signals and then at the desired switching frequency.
4. The system is now ready for application testing under load conditions.
5. Check thermal conditions to verify that the system is operating within specified temperature range.
6. Do NOT apply High Voltage to the SiC Module without first applying power to the GDB.

## Mechanical Dimensions

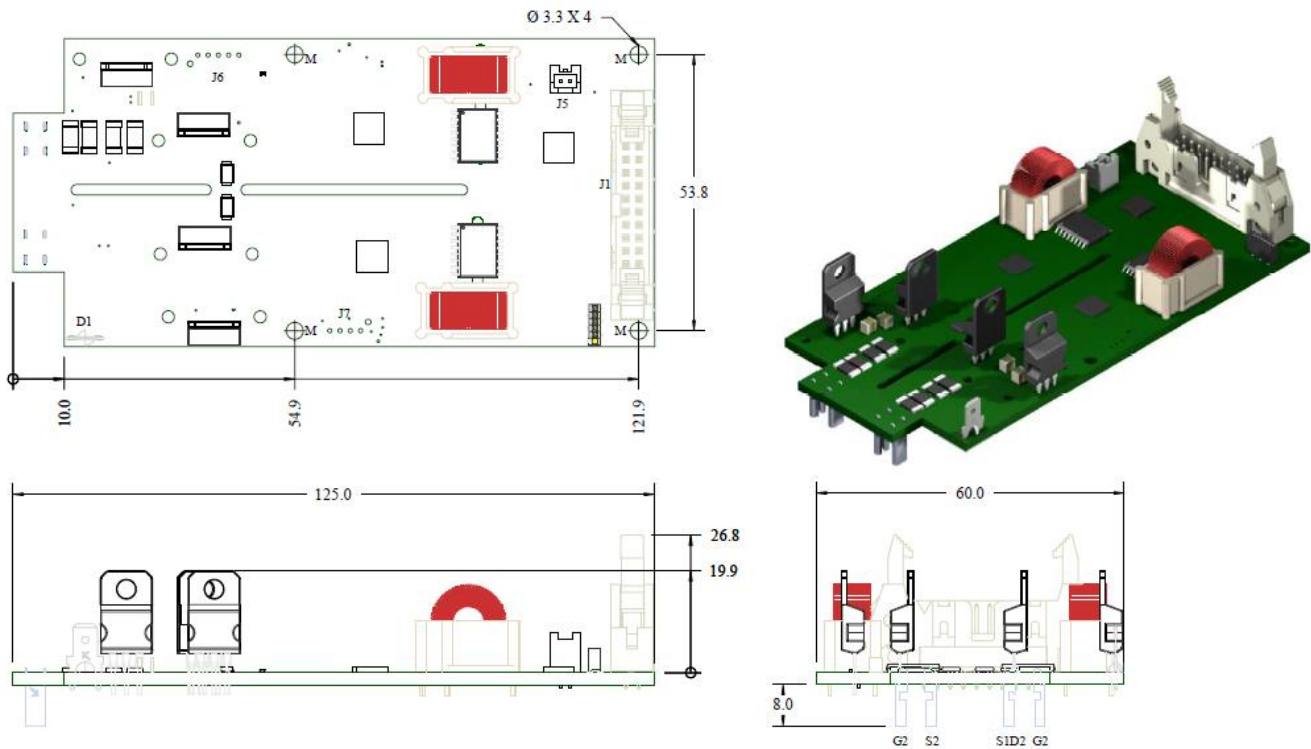

Figure 11: Dimensions of the 62EM1-62mm Electrical Gate Driver (+/- 0.1mm)

Dimensions are in mm.

Download the full drawing and model for additional details. Not all components are shown.

[62EM1 Drawing](#)

[62EM1 .STEP Model](#)

## Revisions

Prepared By	Approved By	Version	Date	Description
N. Satheesh A. Fender	A. Charpentier	01	10/14/2016	Preliminary Release
N. Satheesh		02	10/24/2016	Added Patent Number
A. Fender		03	1/16/2017	Updated characteristics, mechanical drawing
A. Fender		04	5/22/2017	Updated mechanical drawing
A. Fender	N. Satheesh	05	6/16/2017	Added part number info. for thermistor connector, de-glitch time
N. Satheesh	A. Fender	06	10/9/2017	Beta Release to reflect lifetime & power testing
A. Fender	A. Smith	07	11/16/2017	Modified Fault & Monitoring conditions table

