

DESCRIPTION

This monolithic integrated circuit is an adjustable 3-terminal positive voltage regulator designed to supply more than 0.1A of load current with an output voltage adjustable over a 1.2 to 37V. It employs internal current limiting, thermal shut-down and safe area compensation.

FEATURE

- Internal thermal overload protection
- Internal short circuit current limiting
- Output transistor safe operating area compensation

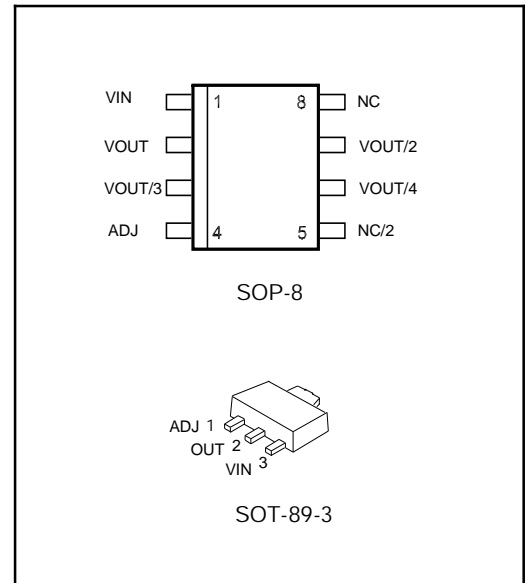

Internal Block Diagram

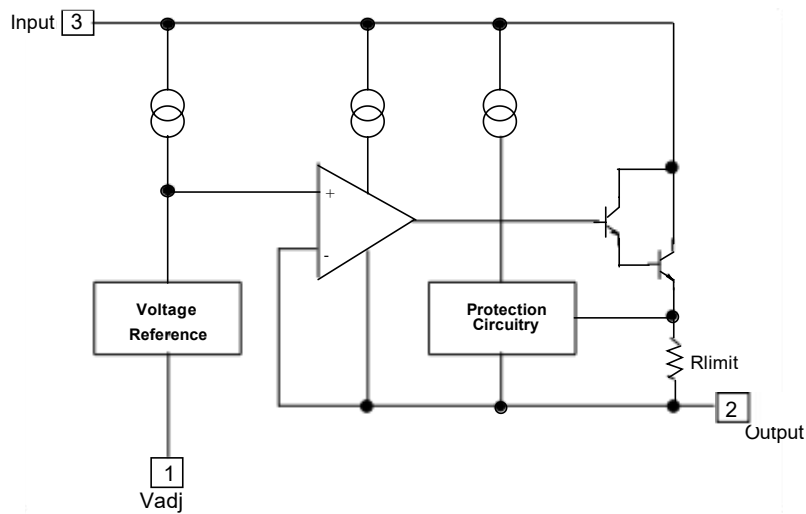

Absolute Maximum Ratings

Symbol	Parameter		Value	Unit
V_I-V_O	Input-Output Voltage Differential		40	V
T_{LEAD}	Lead Temperature		230	°C
P_D	Power Dissipation	SOT-89	400	mW
		SOP-8	400	
T_J	Operating Junction Temperature Range		0~125	°C
T_{stg}	Storage Temperature Range		-55~125	
$\Delta V_O/\Delta T$	Temperature Coefficient of Output Voltage		±0.02	%/°C

ELECTRICAL CHARACTERISTICS

($V_O-V_I=5V, I_O=0.5A, 0^\circ C \leq T_J \leq +125^\circ C, I_{MAX}=1.5A, P_{DMAX}=20W$, unless otherwise specified)

Parameter	Symbol	Test conditions	MIN	TYP	MAX	UNIT
Line Regulation(note1)	R_{line}	$T_A=25^\circ C$ $3V \leq V_I-V_O \leq 40V$		0.01	0.04	%V
		$3V \leq V_I-V_O \leq 40V$		0.02	0.07	
Load Regulation(note1)	R_{load}	$T_A=25^\circ C, 10mA \leq I_O \leq I_{MAX}$ $V_O < 5V$ $V_O \geq 5V$		18 0.4	25 0.5	mV
		$10mA \leq I_O \leq I_{MAX}$ $V_O < 5V$ $V_O \geq 5V$		40 0.8	70 1.5	% V_O
Adjustable Pin Current	I_{ADJ}	-		46	100	μA
Adjustable Pin Current Change	ΔI_{ADJ}	$3V \leq V_I-V_O \leq 40V$ $10mA \leq I_O \leq I_{MAX}, P_D \leq P_{MAX}$		0.2	5	
Reference Voltage	V_{REF}	$3V \leq V_{IN}-V_O \leq 40V$ $10mA \leq I_O \leq I_{MAX}, P_D \leq P_{MAX}$	1.20	1.25	1.30	V
Temperature Stability	ST_T	-		0.7		%/ V_O
Minimum Load Current to Maintain Regulation	$I_{L(MIN)}$	$V_I-V_O=40V$		3.5	5	mA
Maximum Output Current	$I_{O(MAX)}$	$V_I-V_O \leq 3-13V, P_D \leq P_{MAX}$ $V_I-V_O \leq 40V, P_D \leq P_{MAX}$	100	200 50		mA
RMS Noise,% of V_{OUT}	e_N	$T_A=25^\circ C, 10Hz \leq f \leq 10KHz$		0.003	0.01	%/ V_O
Ripple Rejection	RR	$V_O=10V, f=120Hz$ without C_{ADJ} $C_{ADJ}=10\mu F$ (note2)	66	65 80		dB
Long-Term Stability, $T_J=T_{HIGH}$	ST	$T_A=25^\circ C$ for end point measurements, 1 0 0 0 HR		0.3	1	%
Thermal Resistance Junction to case	$R_{\theta JC}$	-		5		°C/W

Notes:

- Load and line regulation are specified at constant junction temperature. Change in V_D due to heating effects must be taken into account separately. Pulse testing with low duty is used.($P_{MAX}=20W$)
- C_{ADJ} - when used, is connected between the adjustment pin and ground.

Typical Application

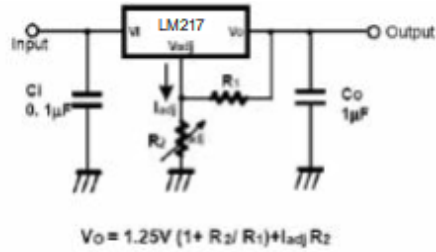

C_i is required when regulator is located an appreciable distance from power supply filter.

C_o is not needed for stability, however, it does improve transient response.

Since I_{ADJ} is controlled to less than $100\mu A$, the error associated with this term is negligible in most applications.

SOP-8

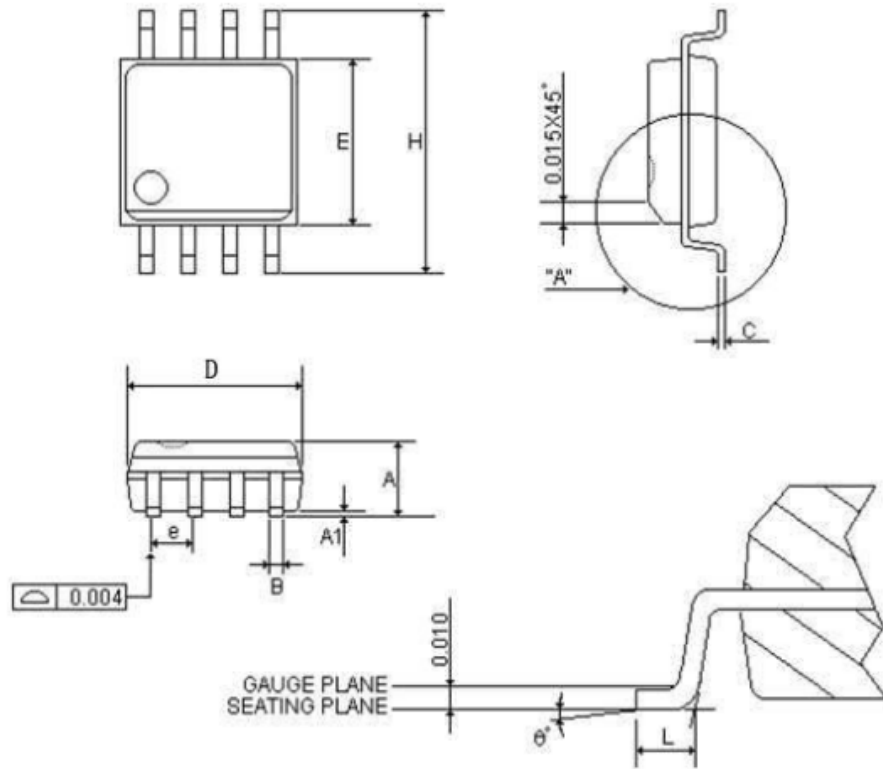

SYMBOLS	MIN	NOR	MAX	MIN	NOR	MAX
	(inch)			(mm)		
A	0.058	0.064	0.068	1.4732	1.6256	1.7272
A1	0.004	-	0.010	0.1016	-	0.254
B	0.013	0.016	0.020	0.3302	0.4064	0.508
C	0.0075	0.008	0.0098	0.1905	0.2032	0.2490
D	0.186	0.191	0.196	5.9944	6.1214	6.1976
E	0.150	0.154	0.157	3.81	3.9116	3.9878
e	-	0.050	-	-	1.27	-
H	0.228	0.236	0.244	5.7912	5.9944	6.1976
L	0.015	0.025	0.050	0.381	0.635	1.27
0°	0°	-	8°	0°	-	8°

SOT-89-3

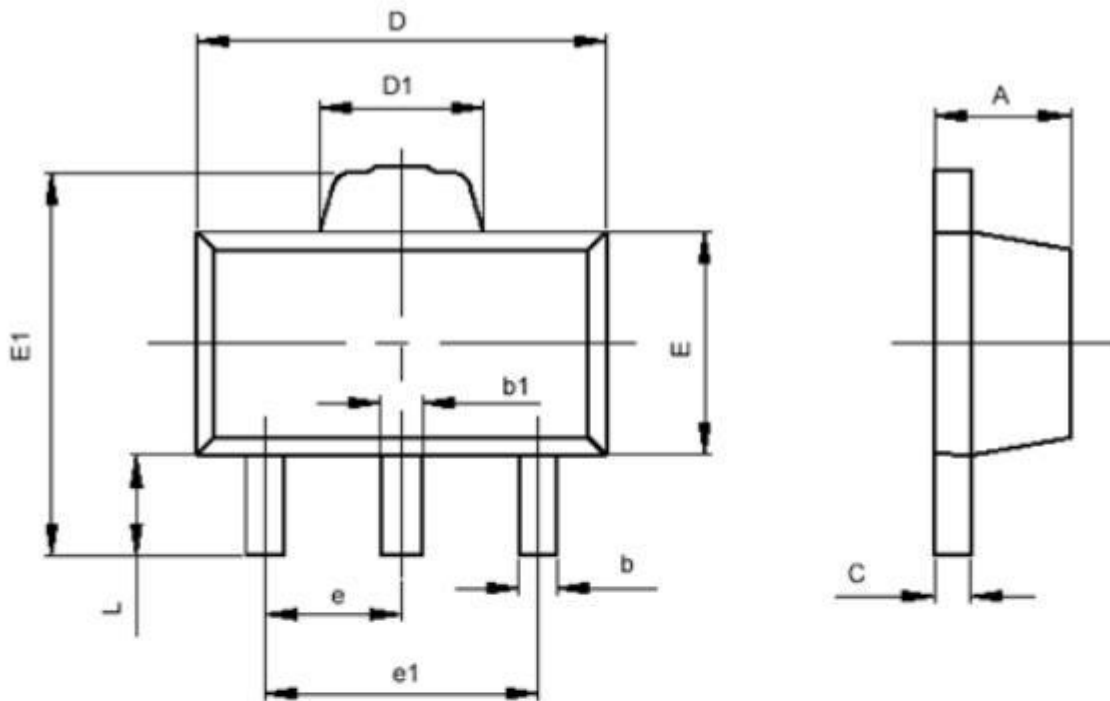

符号	最小值 (mm)	最大值 (mm)
A	1.400	1.600
b	0.320	0.520
b1	0.360	0.560
c	0.350	0.440
D	4.400	4.600
D1	1.400	1.800
E	2.300	2.600
E1	3.940	4.250
e	1.500TYP	
e1	2.900	3.100
L	0.900	1.100

Ordering information

Order code	Package	Baseqty	Deliverymode
UMW LM217LD	SOP-8	2500	Tape and reel
UMW LM217LIPK	SOP-89	1000	Tape and reel