

RoHS
Compliant
Drawing For
Reference Only

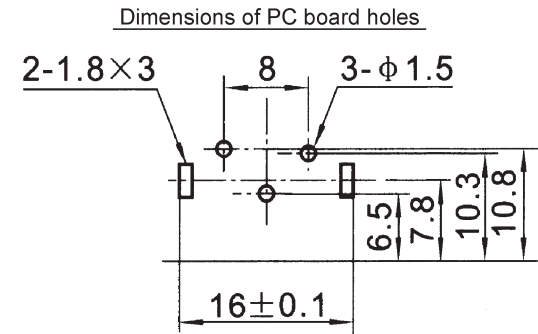

Circuit Diagram

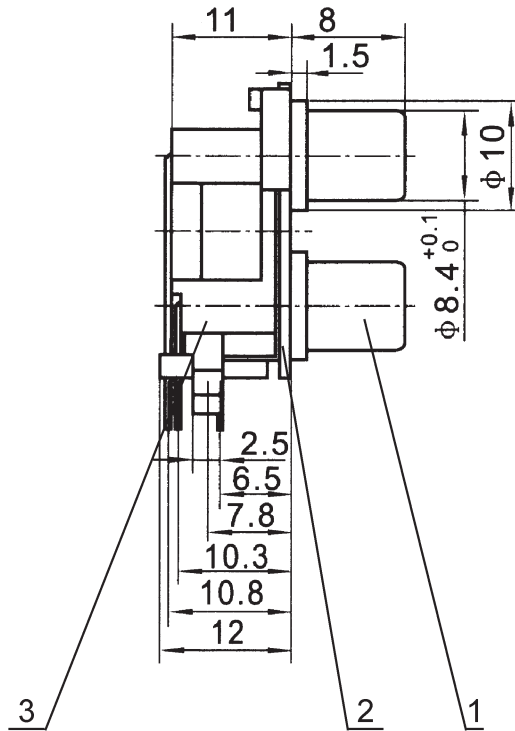
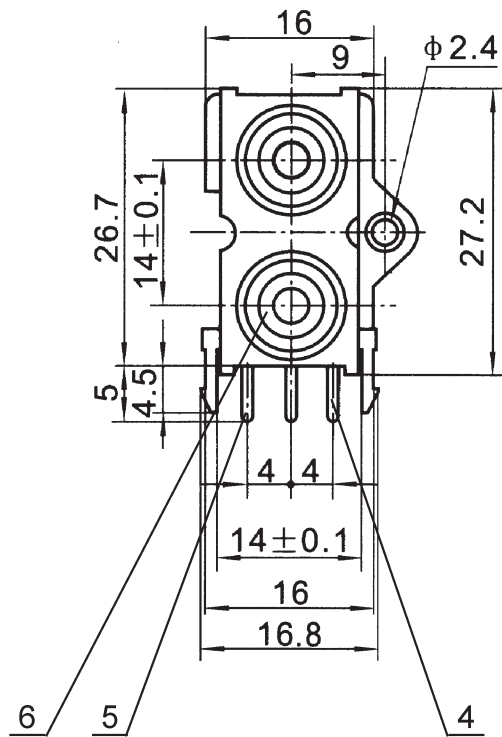
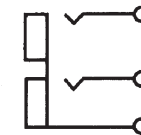

Color Layout



Technical requirement :

1. This product should meet EU RoHS related requirement.
2. The surface of plastic part should be without any crackle such as burr,lack,and so on phenomenon.
3. The surface of metal part should be without any defect such as scaur,nick,oxidation and plating problem.
4. The electronic performance should be the same as spec.
5. The un-specified tolerance is : <math><6\pm 0.1</math>
 6~20± 0.2
 >20± 0.3

6	Washer	2	ABS Resin 94HB	-----
5	Pincer Needle (L)	1	QSn6.5-0.1 t=0.5	D.Ni/Sn
4	Pincer Needle (S)	1	Qsn6.5-0.1 t=0.5	D.Ni/Sn
3	Base	1	ABS (Black) 94HB	-----
2	Cover	1	ABS Resin 94HB	-----
1	Outer Conductor (Couplet)	1	H65 Brass t=0.4	D.Cu/Sn
No.	Name	QTY	Material	Coat Cladding Material

DCI DRAGON CITY INDUSTRIES LIMITED

Design	K.W Law	Remark	Scale
Drawing	W.K Yeung	Remark	Material
Check	K.L Wong	Remark	Dwg No. 80715-1550
Approval	K.W Chan	Remark	Sheet

Item Name	RCA Jack Board	Tolerance :
Item No.	RS-209	Unit : mm