

RoHS
Compliant
Drawing For
Reference Only

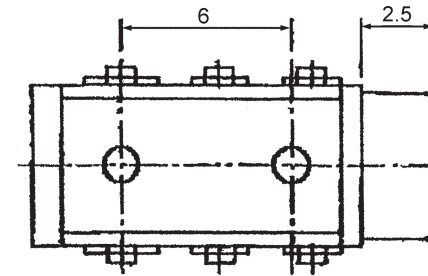

Schematic

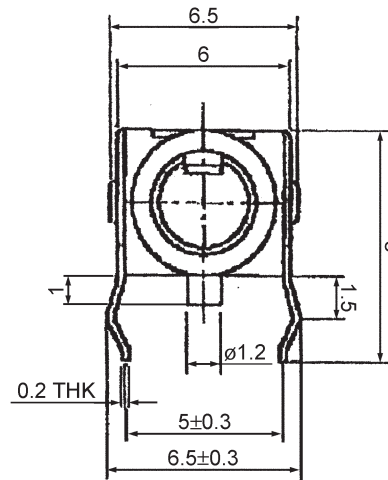
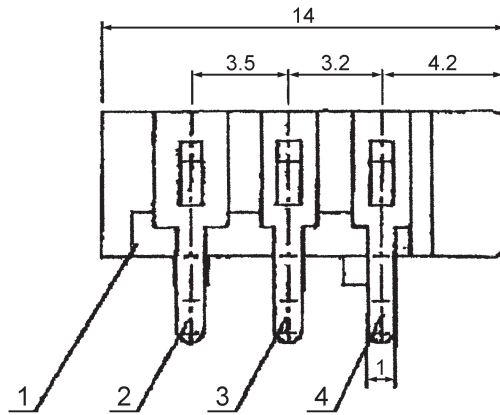
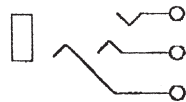

P.C.B Layout

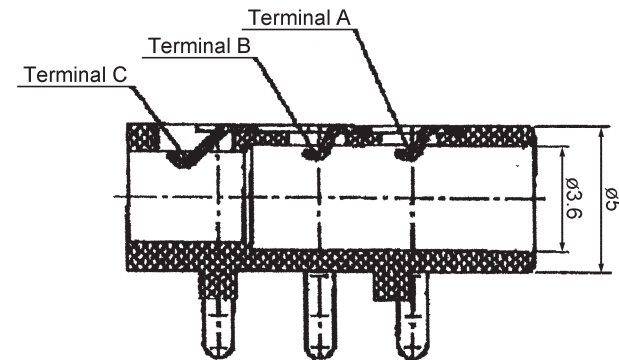
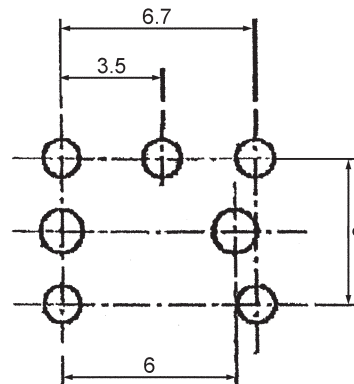

Technical requirement :

1. This product should meet EU RoHS related requirement.
2. The surface of plastic part should be without any crackle such as burr,lack,and so on phenomonen.
3. The surface of metal part should be without any defect such as scaur,nick,oxidation and plating problem.
4. The electronic performance should be the same as spec.
5. The un-specified tolerance is : <math> < 6\pm 0.1 </math>
 6~20±0.2
 >20±0.3

4	Terminal A	Stainless Steel	1	Ag Plated Over Ni Plated
3	Terminal B	PBS Strip	1	Ag Plated Over Ni Plated
2	Terminal C	Stainless Steel	1	Ag Plated Over Ni Plated
1	Case	PC / Nylon+94V0+F.G	1	Green / Black
No	Part Name	Material	QTY	Finishing

DCI DRAGON CITY INDUSTRIES LIMITED

Design	K.W Law	Remark	Scale
Drawing	W.K Yeung	Remark	Material
Check	K.L Wong	Remark	Dwg No. 80805-1058
Approval	K.W Chan	Remark	Sheet

Item Name 3.5mm Phone Jack Tolerance :

Item No. ST-033 Unit : mm