

CAD FILE:

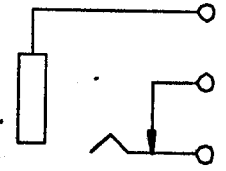
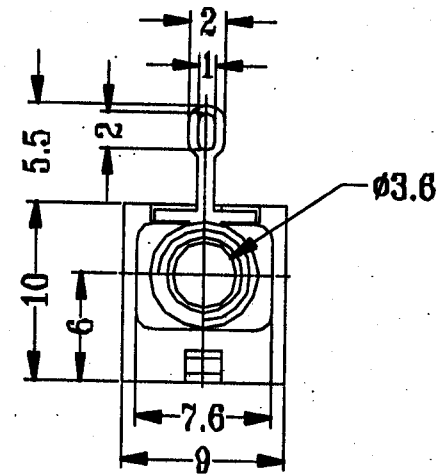
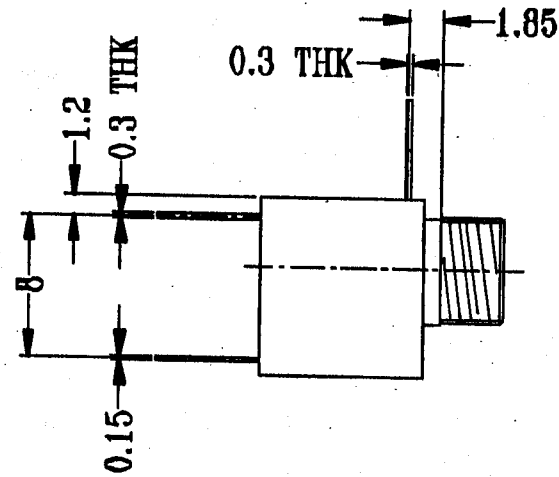
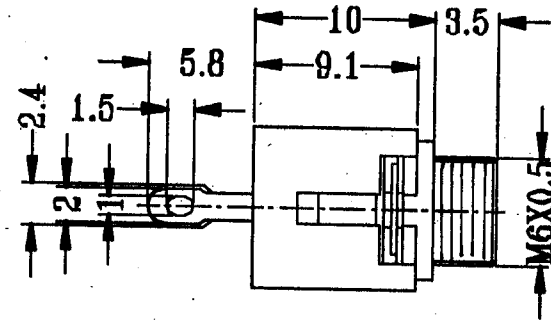

SCHEMATIC

8										
7										
6										
5	TERMINAL	BRASS STRIP	1	Ag PLATED OVER NI PLATED	TOLERANCE UNLESS SPECIFIED WITHIN: 1.5±0.1mm OVER : 1.5±0.2mm	ISSUE	DATE	DESCRIPTIONS	APPD.	
4	SOCKET	BRASS	1	NI PLATED						
3	CASE	ABS	1	MILKY WHITE	TITLE : PHONE JACK		UNIT : MM	DRWG NO.: SF-DE-EY602-00		
2	SPRING TERMINAL	STAINLESS STEEL	1	Ag PLATED OVER NI PLATED	MODEL: EY-502C		SCALE: 3:1	DWN.	黄子君	00-Sep-2003
1	TERMINAL	BRASS STRIP	1	Ag PLATED OVER NI PLATED	DRAGON CITY INDUSTRIES LTD.			CHK'D		
NO.	PART NAME	MATERIAL	Q'TY	FINISHING					APPD.	