

AVK 8 3.662.409

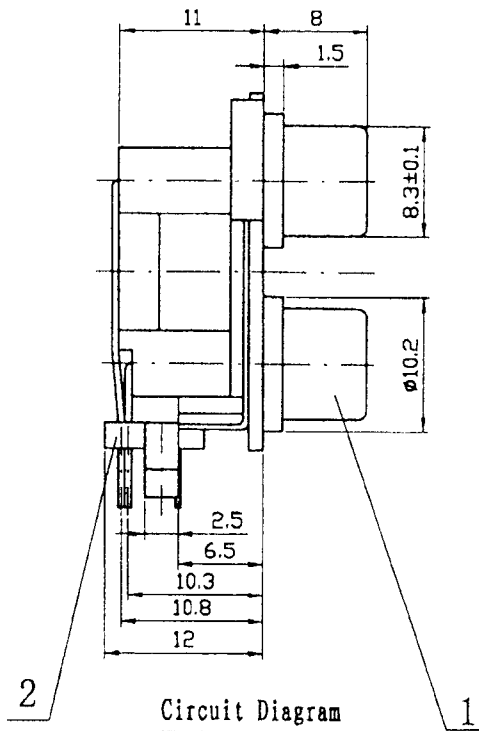

Circuit Diagram

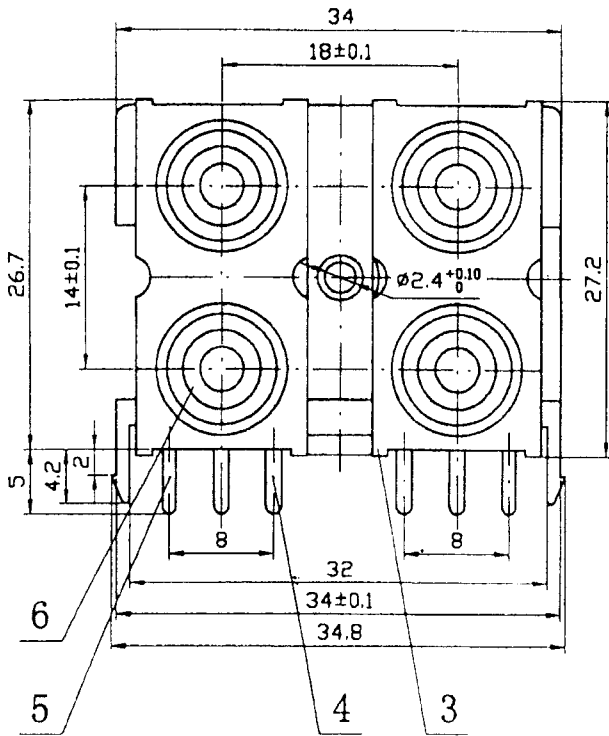
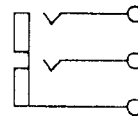

Dimensions of PC board hole

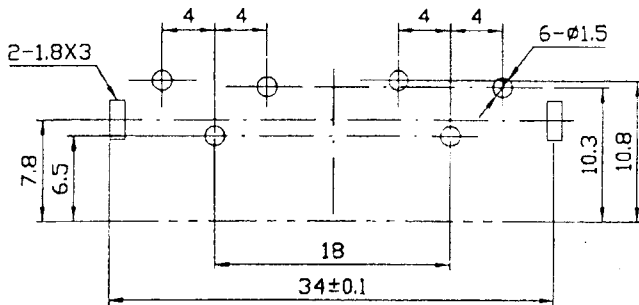

Technical requirement:

1. The cadmium content in this product less than 5PPM. The plumbum content in this product less than 100PPM [meet Sony's standard SS-00259(III)]
2. The surface of plastic part should be without any crackle such as burr, lack, and so on phenomenon.
3. The surface of metal part should be without any defect such as scour, nick, oxidation and plating problem.
4. The electronic performance should be the same as spec.
5. The un-specified tolerance is : 0-6±0.1
6-20±0.2
>20±0.3

Color Layout

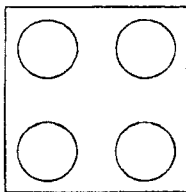

6	Washer	4	ABS Resin 94HB	---
5	Contact Needle(L)	2	QSn6.5-0.1 t=0.5	D. CuSn
4	Contact Needle(S)	2	QSn6.5-0.1 t=0.5	D. CuSn
3	Cover	2	ABS Resin 94HB	---
2	Base	1	ABS Resin 94HB	---
1	Outer Conductor	2	Brass H65 t=0.4	D. CuSn
NO.	Name	QTY	Material	Plated

er of Old Base Map

er of Base Map

er Signer

RS-409

4P RCA JACK

Sign	Place Number	Changed document number	Signer	Date
Designer	Jiazhou Ding	Standardization		
Verifier	Jiamei	Approved	Baoxiufeng	
Technology	Zhouxin	Date	2004.10.27	

Design Mark	Weight	Proportion
A B		2:1
1 piece together		the first piece

