



- Sub miniature
- Up to 60A 12VDC switching
- Special option for motor loads
- Cost effective

ROHS
Compliant

Contacts

Contact arrangement	SPDT (1 Form C); SPST-NO-DM (1 Form U)	
Contact material	AgNi 90/10, AgNi 0.15, AgSnOInO	
Max. switching voltage	DC	16VDC (consult factory for 24VDC)
Min. switching current / voltage	AgNi0.15	1mA /1VDC
Rated load (DC1)	SPDT	25A /12VDC
	SPST-NO-DM	2 x 10A
Max. continuous current (DC1)	SPDT	35A (10 mins) / 25A (1hr)
	SPST-NO-DM	2 x10A (2 mins)
Max. switching current ² (AgSnOInO)	SPDT make	60A
	break	20A
	SPST-NO-DM make	2 x 30A
	break	2 x 10A
Initial contact resistance	≤100mΩ, max. at 0.1A, 6VDC	

Coil

Rated voltage	DC	6V...24V
Operating range / Must release voltage	See Tables 1 & 2	
Rated power consumption	DC	0.6W (standard) - see Table 1
	DC	0.8W (increased contact gap) - see Table 2

Insulation

Insulation resistance	100MΩ at 500VDC, 50%RH	
Dielectric strength	coil to contact	500Vrms, 1min
	contact to contact	500Vrms, 1min

General Data

Operate / Release time	typ.	10ms / 5ms
Electrical Life ³	ops.	1 x 10 ⁵
Mechanical life	ops.	1 x 10 ⁷

Environmental

Ambient temperature	operating / storage	-30 to +85°C / -40 to +125°C
Shock resistance	functional / destructive	10g, 11ms / 100g
Vibration resistance	DA 1.5mm 10-55Hz	
Dimensions	L x W x H	15.7 x 12.3 x 13.8mm (excluding terminal pins)
Weight	approx.	6g

Ordering Code

D G 8 1 - 2 0 1 1 - 2 5 - S 0 1 2 - G H

Series

Contact material
20: AgNi
70: AgSnOInO
80: AgNi0.15

Coil code:
See Tables
1 & 2

Contact arrangement

11: SPDT (1 C/O, 1 Form C)
8U: SPST-NO-DM (1 Form U)

Environmental protection

2: In cover, flux tight - IP40
3: In cover, sealed - IP67

Mounting & terminations

5: PCB Mounting

Options

Blank: No options

F: UL Class F insulation for higher ambient temperatures.
G: Increased contact gap (may be specified with standard, Class F or Class H insulation).
H: UL Class H insulation for high ambient temperatures.

Coil Data (600mW - standard version)

Table 1

Coil code	Nominal voltage (VDC)	Coil Resistance (Ω) $\pm 10\%$	Must operate voltage Max. (VDC)	Must release voltage min. (VDC)
S006	6	60	3.6	0.5
S009	9	135	5.4	0.6
S010	10	167	6.3	0.9
S012	12	240	7.3	1.2
S024	24	960	14.4	2.4

Coil Data (800mW - increased contact gap version) *

Table 2

Coil code	Nominal voltage (VDC)	Coil Resistance (Ω) $\pm 10\%$	Must operate voltage Max. (VDC)	Must release voltage min. (VDC)
1006	6	45	3.6	0.5
1009	9	100	5.4	0.6
1010	10	123	6.3	0.9
1012	12	180	7.3	1.2
1024	24	720	14.4	2.4

* Contact gap increased to 0.45mm. Not available for SPST-NO-DM (1 Form U) contacts.

Overall Dimensions mm

Fig. 1

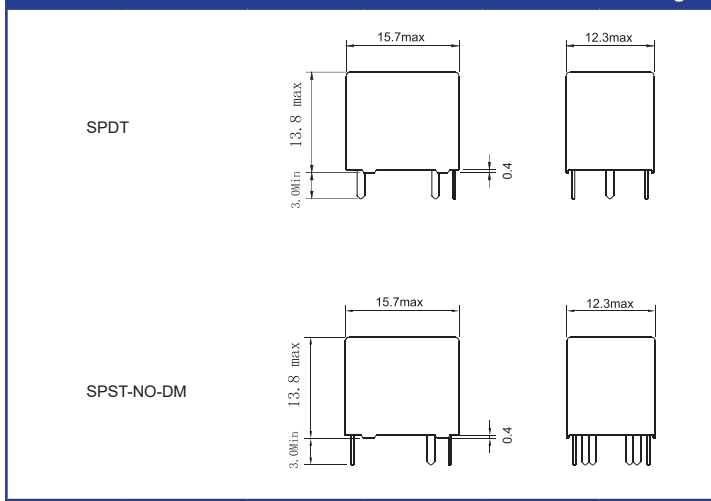

PCB Mounting Dimensions and Wiring mm

Fig. 2

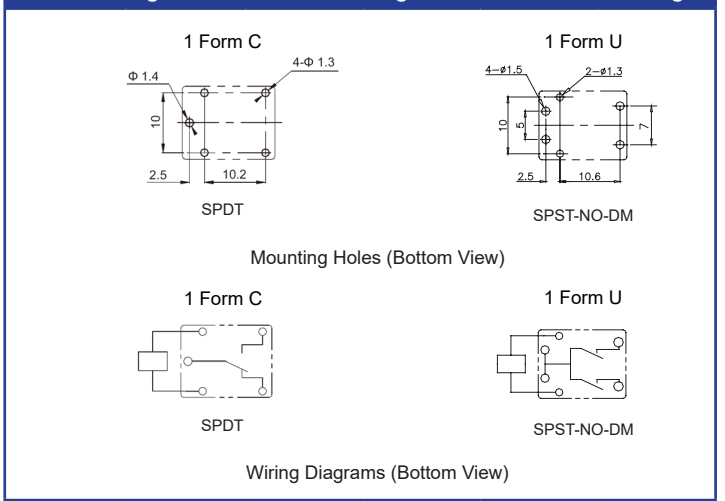

Reference Curves

Fig. 3

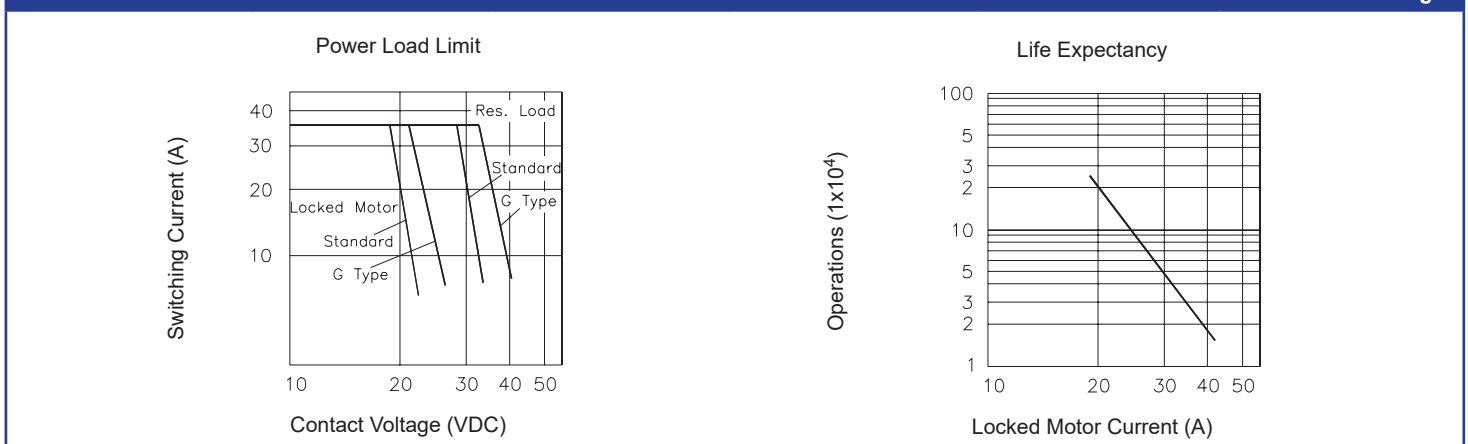

Notes:

- 1: All parameters, unless otherwise specified, are measured at ambient temperature of 23°C.
- 2: Maximum make current refers to inrush current of motor load.
- 3: Electrical life of SPDT obtained at motor load of locked rotor at 20A, 14VDC or resistive load of 10A, 14VDC. SPST-NO-DM at 2x6A, 14VDC resistive, with operating frequency of 6 ops/min.
- 4: Electrical life is strongly dependent of switching frequency, On/Off ratio and environmental conditions.