

**Materials**

1. Insulator, PBT + 15% GF, black
2. Pin, C3604 brass, 2 μm nickel plated
3. Shell, C3604 brass, 2 μm nickel plated
4. Spring contact, C5191 phosphor bronze, 2 μm nickel plated

**Electrical requirements**

Dielectric strength: 1 min @ 500 Vac  
 Insulation resistance: 100 MΩ @ 500 Vdc  
 Contact resistance: 30 mΩ or less

**Mechanical requirements**

Insertion force: 0.3-3 kgf  
 Withdrawal force: 0.3-3 kgf  
 Durability: 5000 mating cycles while maintaining; 0.3 kgf min. insertion force, 0.2 kgf min. withdrawal force and a less than 100 mΩ contact resistance.

**Environmental requirements**

Damp test: 40 °C, RH 90-100% for 96 hrs. Cool to ambient and recover for 2 hours. Maintain dielectric strength of 500 Vac for 1 min, insulation resistance of 50 MΩ @ 500 Vdc minimum and a contact resistance of 100 mΩ or less.

Dry test: 70 °C, RH 70-85% for 96 hrs. Cool to ambient and recover for 2 hours. Maintain insulation resistance of 50 MΩ @ 500 Vdc minimum and a contact resistance of 100 mΩ or less.

Salt spray test: 35 °C, RH 90-95%, 5% NaCl mist for 24 hrs. Wash parts after test. Maintain mechanical requirements and a contact resistance of less than 80 mΩ.

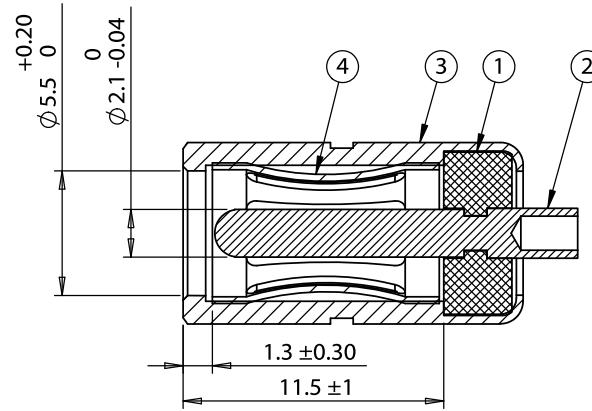

SECTION A-A  
SCALE 3 : 1

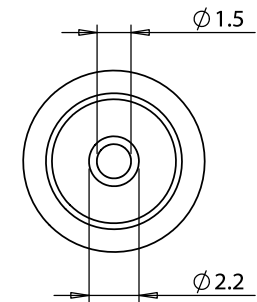
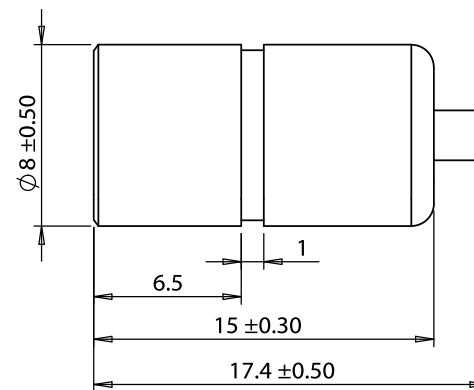
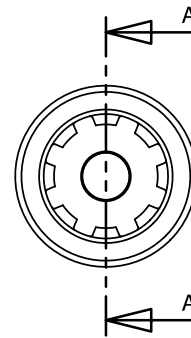

Revision:	Date:	Description:
A	09/02/2009	Intiial release
A1	11/09/2012	Added test data
A2	10/29/2015	Modified electrical requirements
A3	04/19/2016	Modified tolerances
A4	05/22/2018	Changed material and added test data

Prepared:  
JP  
Digitally signed by JP  
Date: 2018.05.25  
10:13:26 -07'00'

Verified:  
AG  
Digitally signed by AG  
Date: 2018.05.25  
10:23:26 -07'00'

Dimensions are in millimeters.  
 Tolerances:  
 X: ± 0.5 mm  
 X.X: ± 0.3 mm  
 X.XX: ± 0.05 mm

Notes:  
RoHS compliant

Function test: no open, no short circuit, no intermittent

Description:  
Connector, dc jack, 5.5x2.1xL17.4 mm, molding style

**TENSILITY**

tel 1.541.323.3228 800 877.670.7118  
 fax 1.541.323.4202 web tensility.com

Size: A	Part number: 50-00025
Scale: 4:1	Sheet 1 of 2

