

PART NUMBER	DESCRIPTION	SWITCHCRAFT MATING 2.1mm POWER PLUGS
721RA	2.1mm POWER JACK, RIGHT-ANGLE PC	762, 763, 762K, 763K

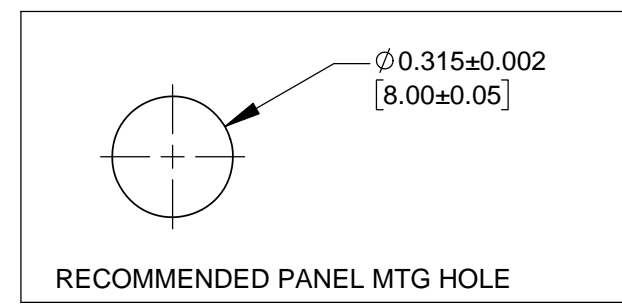
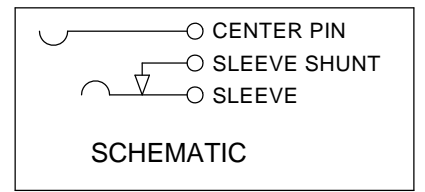
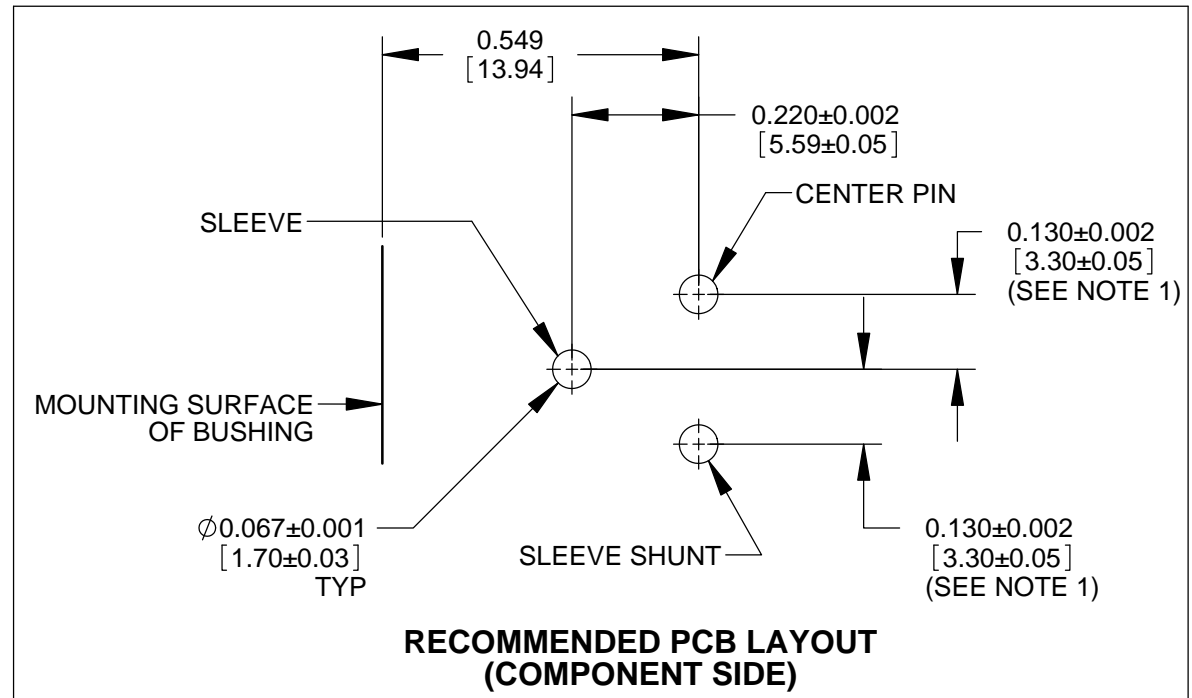
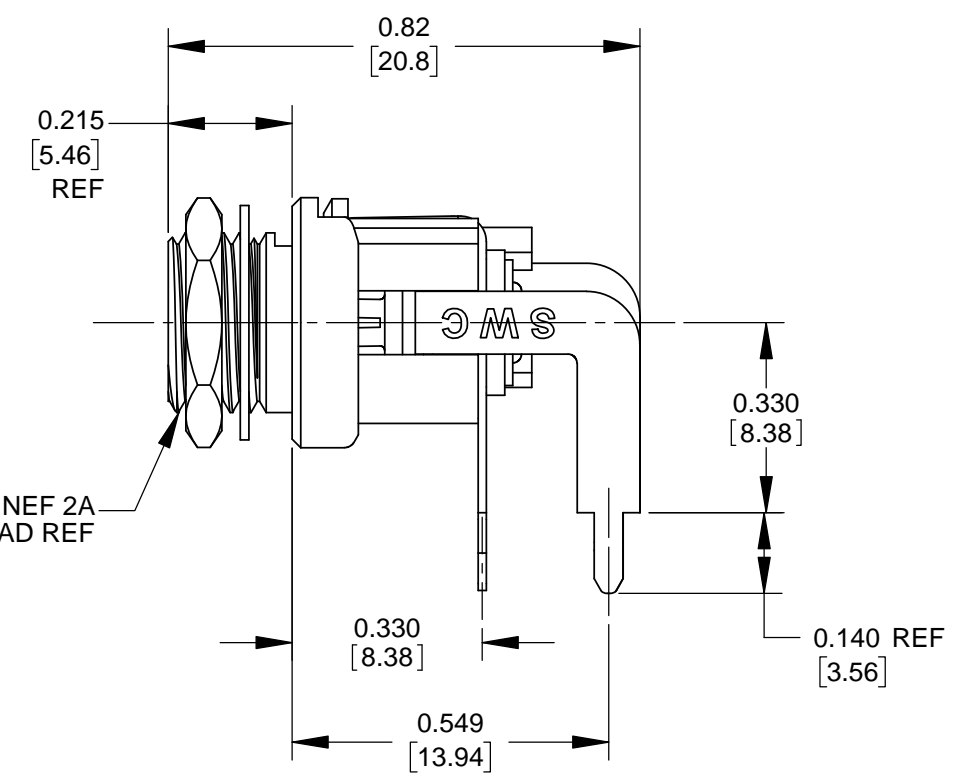
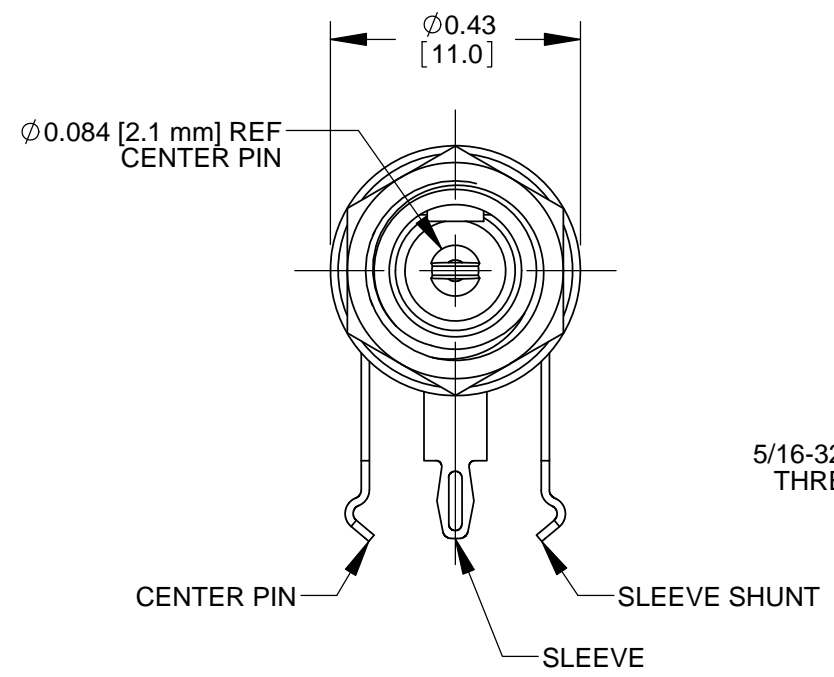

- NOTES:
- FOR HAND INSERTION USE SPACING 0.130 [3.30]
FOR AUTOMATED INSERTION USE SPACING 0.135 [3.43]
 - DIMENSIONS SHOWN FOR REFERENCE ONLY.
 - HEX NUT AND FLAT WASHER SUPPLIED UNASSEMBLED.
 - MATERIAL:
HOUSING, HEX NUT - COPPER ALLOY, NICKEL PLATED
INSULATOR HOUSING - THERMOPLASTIC, RED
TERMINAL INSULATORS - PHENOLIC
FLAT WASHER - STEEL, NICKEL PLATED
PIN, SPRING, TERMINALS - COPPER ALLOY, SILVER PLATED
 - THESE PRODUCTS ARE RoHS COMPLIANT.

CUSTOMER DRAWING

REV	ECO NUMBER	DATE	BY	APVD
A	27987	01/08/18	PC	TJK
REVISIONS				

UNLESS OTHERWISE SPECIFIED

- ALL DIMENSIONS IN INCHES [mm]
- TWO PLACE DECIMALS ±0.02 [0.5]
- THREE PLACE DECIMALS ±0.005 [0.13]

DO NOT SCALE DRAWING

THIS DRAWING DESCRIBES A DESIGN CONSIDERED PROPRIETARY IN NATURE, DEVELOPED AND MANUFACTURED BY SWITCHCRAFT INC. AND IS RELEASED ON A CONFIDENTIAL BASIS FOR IDENTIFICATION PURPOSES ONLY.									
SIZE	WIDTH	MULT	LBS/M	TEMPER					
FINISH SPEC No.					MATERIAL SPEC No.				
FIRST USED ON					SCALE 3:1				
DATE DRAWN	BY	CHKD	APVD						
02/08/17	PNK	PNK	SRC						
			02/08/17	02/08/17					
NAME 2.1mm POWER JACK RIGHT-ANGLE PC, RoHS					PART No. 721RA		REV A		