

CUSTOMER TERMINAL	ROHS	Lead (Pb) -free
	YES	YES

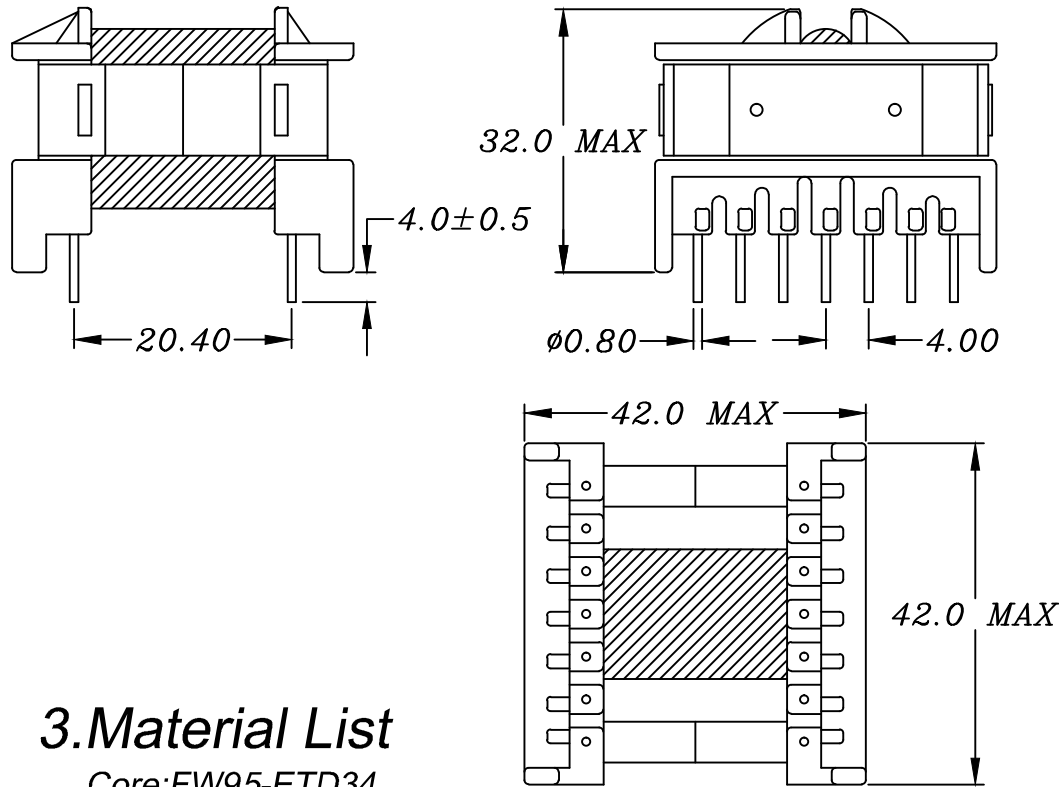

1. Mechanical Dimensions (Unit:mm)



2. Schematic Diagram

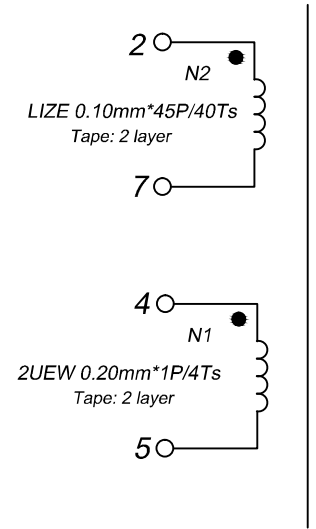

3. Material List

Core:FW95-ETD34
 Bobbin:ETD34 7+7PIN
 Wire:2UEW 0.20mm LIZE 0.1mm*45P 155°C
 Tapes: JY25-A1
 Vranish:T4260GK

4. Electrical Specification

Inductance: L(2-7)=240uH±10% 100KHZ 1.0V
 Hi-pot: COIL to CORE AC 50HZ 500V2mA3SEC

REV.	DATE	 Convention Placement	DRW.	Pan Yucai	Drawing Title: TRANSFORMER	Part No:	FWPTETD34H-241K
0	04/15		CHK.	Zhu Kan		Customer P/N:	ETD-34-PFC-LITZ
RoHS		www.ferriwo.com	APP.	Xia Xiaokai	Specification Sheet 1 of 1		