

DO NOT SCALE FROM THIS PRINT

- NOTES:
1. CONNECTOR HEIGHT NOT AVAILABLE AS STANDARD.
 2. REPRESENTS A CRITICAL DIMENSION.
 3. CONTACT TO BE FLUSH ±.002[0.05] TO BE MEASURED AT ALL 4 CORNERS.
 4. PARTS TO BE PACKAGED IN TAPE & REEL.
FOR QUANTITIES LESS THAN 125 PCS, NO TRAILER OR LEADER WILL BE SUPPLIED.
 5. DELETED.
 6. MINIMUM PUSHOUT FORCE: .5 LB
 7. ONE REEL MINIMUM PLATING REQUIREMENT (85,000 CONTACTS PER REEL).
 8. ALL DIMS TO BE SYMMETRICAL ABOUT THE CENTERLINE WITHIN ±.001[0.03].
 9. MAXIMUM VARIATION BETWEEN SOLDERBALLS: .0025[0.064]
 10. REFER TO VISUAL INSPECTION BOARD FOR SOLDERBALL APPEARANCE CHECKS.
 11. THE DISTANCE FROM THE CENTER OF ANY SOLDERBALL TO THE CENTER OF ANY ADJACENT INNER PEG SHALL BE .025±.005[0.64±0.13].
 12. SOLDER JOINTS TO BE INSPECTED PER IPC SPECIFICATION 12.2.12 (IPC-A-610C).

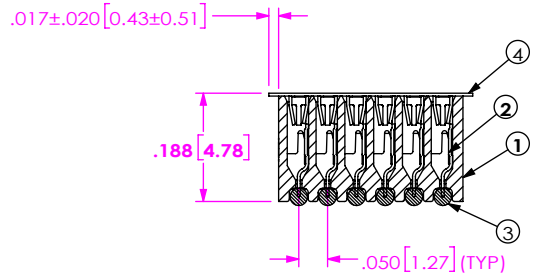
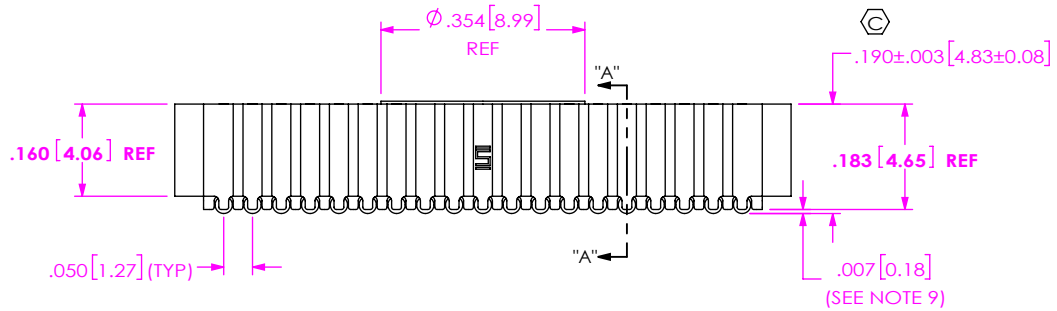
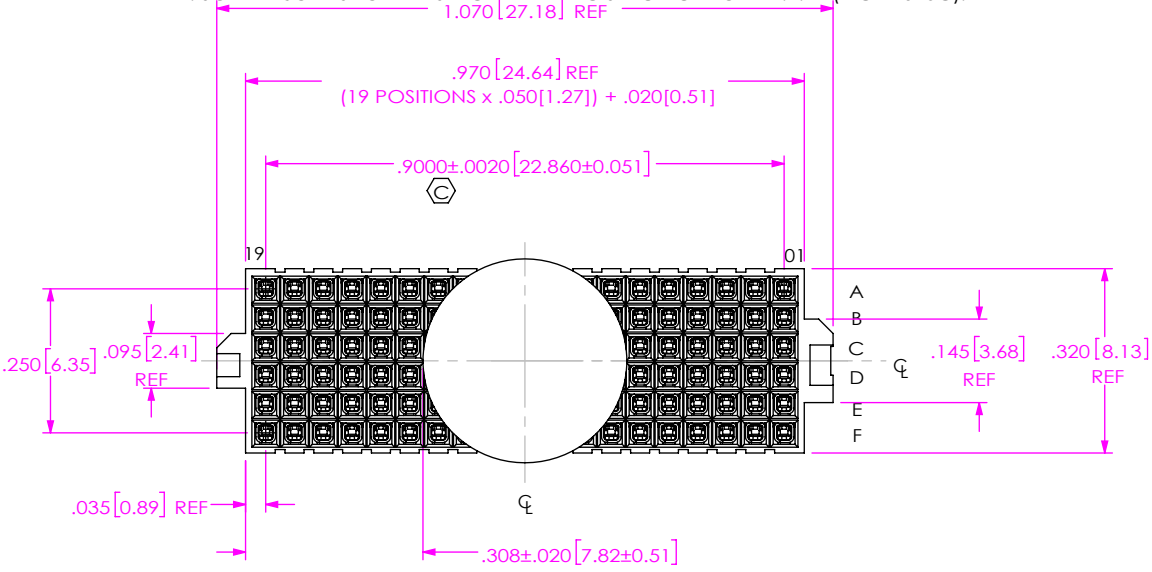
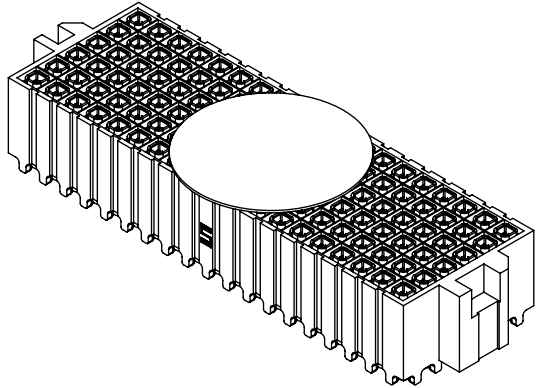

SECTION "A"- "A"

ITEM NO.	PART NUMBER	QUANTITY	MATERIAL
1	ASP-167045-01-B	1.0000	LCP, COLOR: BLACK
2	ASP-190171-02-P-H-SUB	114.00	PHOS BRONZE
3	SDB-030-6337	114.00	63% TIN /37% LEAD
4	K-DOT-.354-.469-.005	1.0000	POLYIMIDE FILM
5	CT-ASP1949MS	.00222	CONDUCTIVE POLYMER

UNLESS OTHERWISE SPECIFIED, DIMENSIONS ARE IN INCHES.
 TOLERANCES ARE:
 DECIMALS ANGLES
 .XX: ±.01[0.3]
 .XXX: ±.005[0.13]
 .XXXX: ±.0020[0.051]

PROPRIETARY NOTE
 THIS DOCUMENT CONTAINS CONFIDENTIAL AND PROPRIETARY INFORMATION AND ALL DESIGN, MANUFACTURING, REPRODUCTION, USE, PATENT RIGHTS AND SALES RIGHTS ARE EXPRESSLY RESERVED BY SAMTEC, INC. THIS DOCUMENT SHALL NOT BE DISCLOSED, IN WHOLE OR PART, TO ANY UNAUTHORIZED PERSON OR ENTITY NOR REPRODUCED, TRANSFERRED OR INCORPORATED IN ANY OTHER PROJECT IN ANY MANNER WITHOUT THE EXPRESS WRITTEN CONSENT OF SAMTEC, INC.



520 PARK EAST BLVD, NEW ALBANY, IN 47150
 PHONE: 812-944-6733 FAX: 812-948-5047
 e-Mail: info@SAMTEC.com code 55322

DO NOT SCALE DRAWING SHEET SCALE: 3:1
 PLATING:
 CONTACT AREA: .000030 GOLD OVER .000050 NICKEL
 REMAINDER: .000003 GOLD OVER .000050 NICKEL

DESCRIPTION: LEADED VITA ASSEMBLY
 DWG. NO. **ASP-189983-01**
 BY: J. BROWNING 11/04/2015 SHEET 1 OF 2

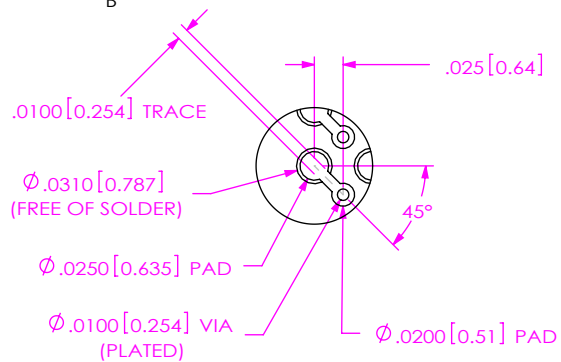
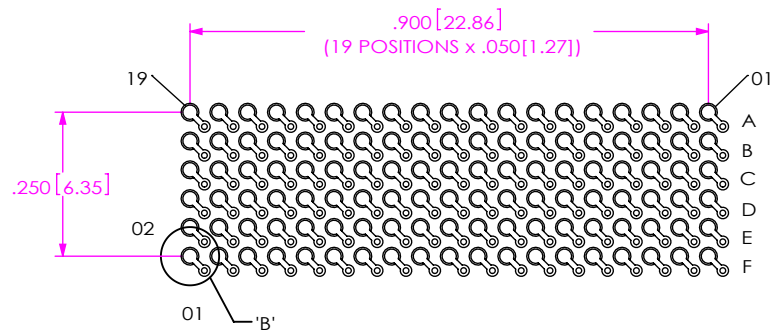

DETAIL 'B'

RECOMMENDED MAIN BOARD LAYOUT

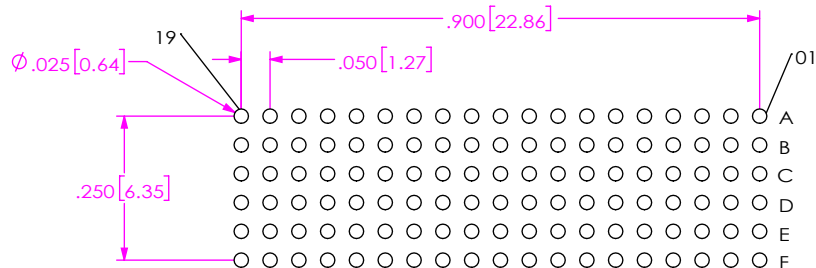

RECOMMENDED STENCIL LAYOUT
STENCIL TO BE .0060 [.152] THICK

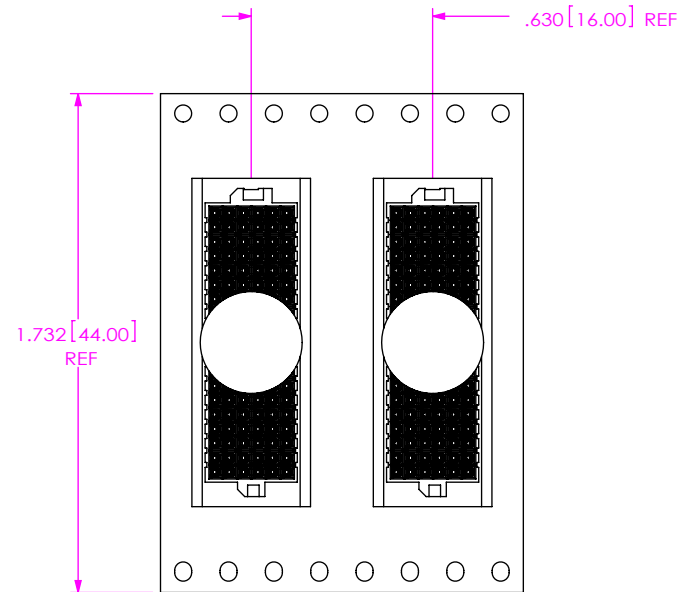

USER DIRECTION OF UN-REELING
POCKET NOT DETAILED

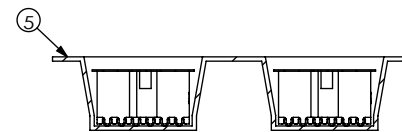

PACKAGING VIEW

PROPRIETARY NOTE

THIS DOCUMENT CONTAINS CONFIDENTIAL AND PROPRIETARY INFORMATION AND ALL DESIGN, MANUFACTURING, REPRODUCTION, USE, PATENT RIGHTS AND SALES RIGHTS ARE EXPRESSLY RESERVED BY SAMTEC, INC. THIS DOCUMENT SHALL NOT BE DISCLOSED, IN WHOLE OR PART, TO ANY UNAUTHORIZED PERSON OR ENTITY NOR REPRODUCED, TRANSFERRED OR INCORPORATED IN ANY OTHER PROJECT IN ANY MANNER WITHOUT THE EXPRESS WRITTEN CONSENT OF SAMTEC, INC.



520 PARK EAST BLVD, NEW ALBANY, IN 47150
PHONE: 812-944-6733 FAX: 812-948-5047
e-Mail: info@SAMTEC.com code 55322

SHEET SCALE: 3:1

DESCRIPTION:
LEADED VITA ASSEMBLY

DWG. NO.
ASP-189983-01

BY: J. BROWNING 11/04/2015 SHEET 2 OF 2

Mouser Electronics

Authorized Distributor

Click to View Pricing, Inventory, Delivery & Lifecycle Information:

[Samtec:](#)

[ASP-189983-01](#)