



Medical



Industrial

FEATURES AND BENEFITS

Small 2" X 3" x 1.2" Form Factor	Approved To UL/CSA/IEC/IEC62368-1
For 1U Applications	2 x MOPP Isolation
65W Convection Cooled	Meets 4th Edition/Heavy Industrial EMC
Universal Input 80-264VAC	-20°C To 70°C Operating Temperature Range
Approved to UL/CSA/IEC/IEC60601-1, 3rd. Ed.	3 Years Warranty



MODEL SELECTION

Model Number	Volts	Output Current Convection Cooled	Output Power	Ripple & Noise*	Total Regulation	OVP Threshold
SLB65S05x	5V	8.0A	40 Watts	0.5%RMS, 1.5% pk-pk	±2%	7.9 ± 1.1V
SLB65S12x	12V	5.0A	60 Watts	0.5%RMS, 1.5% pk-pk	±2%	14.0 ± 1.1V
SLB65S15x	15V	4.0A	65 Watts	0.5%RMS, 1% pk-pk	±2%	18.0 ± 1.5V
SLB65S18x	18V	3.6A	65 Watts	0.5%RMS, 1% pk-pk	±2%	21V± 3.0V
SLB65S24x	24V	2.71A	65 Watts	0.5%RMS, 1% pk-pk	±2%	28.0 ± 4.0V
SLB65S48x	48V	1.35A	65 Watts	0.5%RMS, 1% pk-pk	±2%	55.0 ± 4.0V

Notes: Replace the "x" at the end of the model number with "C" for class II (ungrounded) input or replace with "K" for class I (grounded) input.

INPUT

AC Input Voltage	80-264VAC, Single phase	
AC Input Current	115VAC: TBD 230VAC: 1.0A	
Inrush Current	85A maximum @ 25C	Cold Start 264VAC
Input Fuse	3.15A, 250VAC	Fuse Provided on All Models
Earth Leakage Current	<500uA @ 264VAC, 60Hz input, NC	<100uA Patient Leakage Current
AC Input Frequency	47-63Hz	



EFFICIENCY

Model Number	Typical	Measured @ 25°C
SLB65S12x, SLB65S15x	89% @ 230VAC, Full load	86.5% @ 115VAC, Full load
SLB65S18x	89% @ 230VAC, Full load	87% @ 115VAC, Full load
SLB65S24x	89% @ 230VAC, Full load	87% @ 115VAC, Full load
SLB65S48x	88% @ 230VAC, Full load	88% @ 115VAC, Full load

OUTPUT

Hold-up Time	12ms typical from loss of AC input at 115VAC	
Turn On Time	<2 seconds @115VAC (<3s for 12V output)	
Output Power	Max of 65 Watts for convection cooled	
Ripple and Noise	0.5% RMS, 1%~1.5% pk-pk for all models	20 MHz Bandwidth, differential mode Measured with noise probe directly across output terminals, and load terminated with 0.1μF ceramic and 10μF low ESR capacitors
Transient Response	500μs typ. response time for return to within 0.5% of final value for a 50% load change, $\Delta i/\Delta t < 0.2A/\mu s$ Max voltage deviation is 3.5%	Measured @ 25°C
Minimum Load	No minimum load is required	
Total Regulation	±2% for all models	Total regulation is the maximum deviation from nominal voltage for all loading conditions
Cooling	Convection (65W Output)	
Overshoot	5% overshoot at turn-on, 5% overshoot at turn-off, under all conditions	

ENVIRONMENT

Operating Temperature	-20°C to +70°C	
Temperature Derating	40% derating at 70°C	
Cooling	Convection	
Storage Temperature	-40°C to +85°C	
Altitude	Operating: 500 to 5,000 meters Non-operating: 500 to 40,000 ft	
Relative Humidity	5% to 95%, Non-condensing	
Shock	Non-operating: Half-sine, 40 gpk, 10ms, 3 axes, 6 shocks total	
Vibration	Random vibration per MIL-STD-810E, Method 514.4, Cat. 1, Figure 514.4-1, 1 hr in each of three axes	



SAFETY

UL	EN/CSA/UL/IEC 60601-1 3rd edition BF Rated & EN62368-1
CSA	Same as above
Demko	Same as above
CB Report	Yes
Isolation Type	Double/Reinforced between input and

ISOLATION SPECIFICATIONS

Insulation Safety Rating	Input to Ground	1 x MOPP
	Input to Output	2 x MOPP
Electric Strength Test Voltage	Input to Ground	1500VAC
	Input to Output	4,000VAC
	Output to Ground	1500VAC

PROTECTION

Overtemperature Protection	Will shut down upon an overtemperature condition, auto-recovery.
Overload Protection	120% - 180% of rated output current value, Hiccup mode
Short Circuit Protection	Short across the output terminals will not cause damage to the unit. Hiccup mode
Overvoltage Protection	115% to 130% of nominal output voltage. Latching, recycle AC power to recover.

EMI/EMC COMPLIANCE

Conducted Emissions	EN55011/22 Class B; FCC Part 15 EN55015/CISPR15:2013, CISPR22 2006 Class B, CISPR32 Class B, FCC Part 15.107, Class B: at 115 and 230Vac	
Radiated Emissions	EN55011/22 Class A; FCC Part 15 CISPR15 radiated EN55032/CISPR22 Class B, CIS- PR32 Class B, FCC Part 15.109, Class B: at 115 and 230Vac	
Harmonic Current Emissions	EN61000-3-2, Class A, B, C & D	
Voltage Fluctuations & Flicker	EN61000-3-3	
Static Discharge Immunity	EN61000-4-2, Level 4: 8kV contact,15kV air, Criteria A	
RF Field Susceptibility	EN61000-4-3, Level 3 (3V/m), Criteria A EN55032/EN61000-4-3, 10V/m, 80MHz-2.7GHz, 80% AM at 1kHz IEC60601-1-2, 4th Edition, Table 4	Performance criteria are defined as following: A – Normal performance during and after the test B – Temporary degradation, self-recoverable C – Temporary degradation, operator intervention required to recover the operation
Fast Transients/Bursts	EN61000-4-4, Level 3 (PS: 2kV-40A, other lines 1kV-20A), Criteria A EN55024/IEC61000-4-4, Level 4, +/- 4kV, 100Khz rep rate, 40A, Criteria A IEC60601-1-2, 4th Edition, Table 5	



Surge Susceptibility	EN61000-4-5, Installation Class 3 (1kV diff. mode, 2kV common mode), Criteria A EN55024/IEC61000-4-5, Level 4, +/-2kV DM, +/-4kV CM, Criteria A Surpasses IEC60601-1-2, 4th Edition requirements.	Performance criteria are defined as following: A – Normal performance during and after the test B – Temporary degradation, self-recoverable C – Temporary degradation, operator intervention required to recover the operation
Conducted RF Susceptibility	EN61000-4-6, Level 3 (3Vrms), Criteria A EN55032/IEC61000-4-6, 3V/m – Level 4, 0.15 to 80Mhz; and 12V/m) in ISM and amateur radio bands between 0.15Mhz and 80Mhz, 80% AM at 1KHz IEC60601-1-2, 4th Edition, Table 5.	
Power Frequency Magnetic Field Test	EN61000-4-8, Level 3 (3A/m), Criteria A EN55024/IEC1000-4-8, Level 4: 30A/m, 50/60 Hz IEC60601-1-2, 4th Edition, Table 4	
Voltage Sags & Surges	EN61000-4-11 95% dip/0.5 cycle (Criteria A), 60%/5cycles (Criteria B), 30%/25 cycles (Criteria A) Loading is 70% of 100W with 100VAC EN55024/IEC/EN61000-4-11: --100% dip for 10 mS, at 0, 45, 90, 135, 180, 225, 270 and 315 degrees: --100% dip for 20mS, 0 deg., Criteria A --100% dip for 5000mS (250/300 cycles), Criteria B -- 60% dip for 100mS, Criteria B -- 30% dip for 500mS, Criteria A IEC60601-1-2, 4th Edition, Table 5	

DERATING CURVES

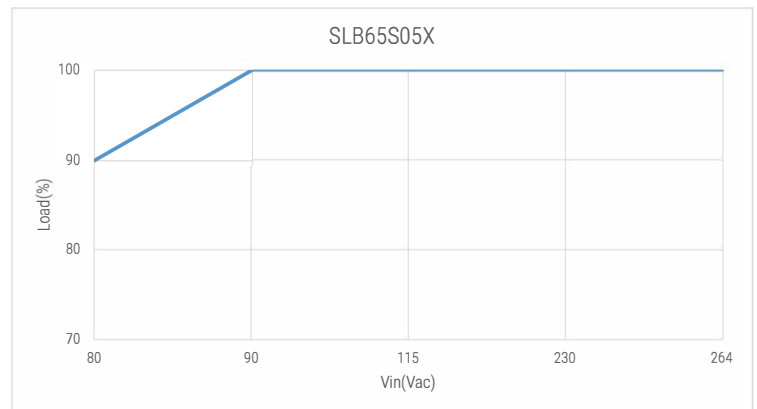
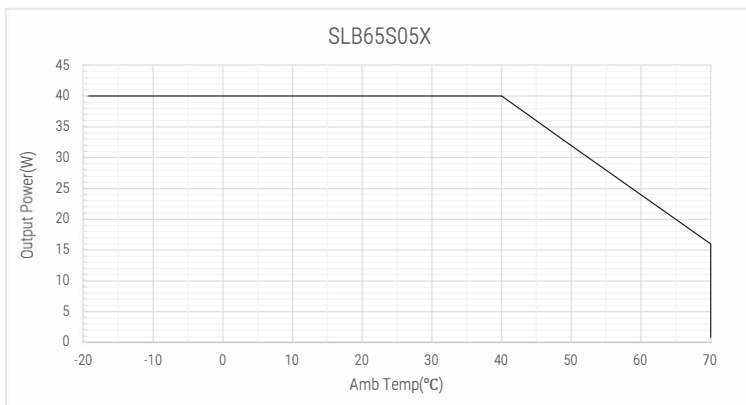



RELIABILITY

MTBF	>500K hours, 25°C ambient, full load	Calculation is done based on Telcordia Reports for each model is available
Warranty	3 Years	
HALT Data	Per SL Power Halt procedure	Report is available

MECHANICAL DRAWING

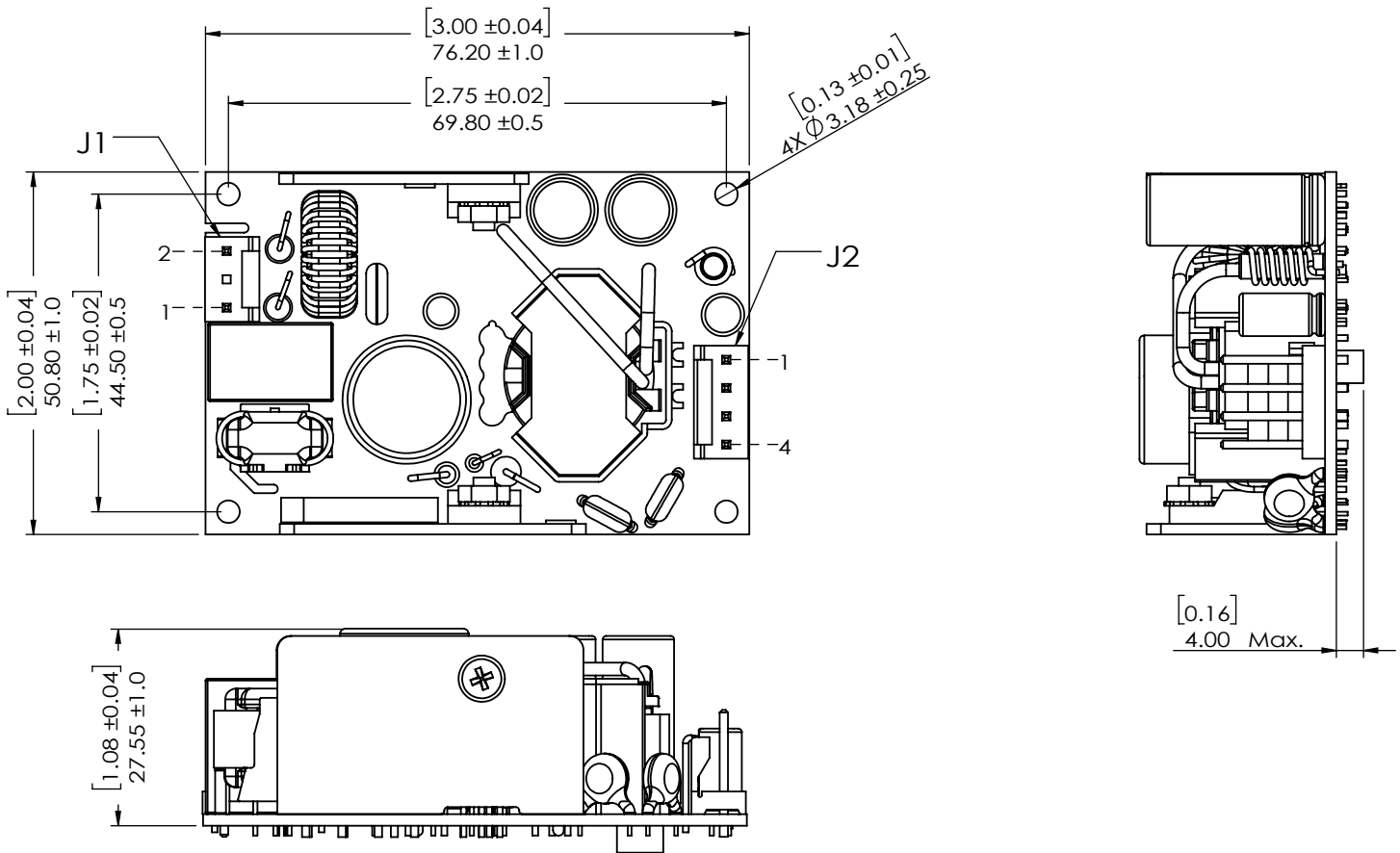

CONNECTOR INFORMATION

SLB65 CONNECTORS

Connector	Pin#	Assignment	Mating Connector	Mating Pin
Input (J1)	1	L	AMP: 640250-3	AMP: 640252-2
	2	Empty		
	3	N		
Ground (G1)	1	Ring type terminal or similar ³		
Output (J2)	1	+V1	AMP: 640250-4	AMP: 640252-2
	2	+V1		
	3	RTN		
	4	RTN		