

APPROVAL SHEET

Issued No. : _____

DESCRIPTION : SMD 8045 Glass Seal CRYSTAL
NOMINAL FREQ. : 12.000000 MHz
TAITIEN P/N : _____
TAITIEN MODEL : XQFCCLNANF-12.000000MHz
REVISION : 1
DATE : _____

QA	Checked	Prepared

CUSTOMER : _____

CUSTOMER P/N : _____

Customer Signature
Approved:
Date:

CONTENT

SPECIFICATIONS	PAGE
ELECTRICAL SPECIFICATIONS	4~5
RECOMMENDED IR REFLOW PROFILE	6
PRODUCT DIMENSIONS	7
PRODUCT IDENTIFICATION (MARKING)	7
PACKAGE INFORMATION	8

ELECTRICAL SPECIFICATIONS

	Parameter	Min.	Typ.	Max.	Units	Test Condition
1-1	Nominal Frequency	12.000000			MHz	
1-2	Frequency Tolerance.	-20		+20	ppm	at 25°C +/-2°C
1-3	Operating Temperature range	-20		+70	°C	
1-4	Storage Temperature range	-55		+125	°C	
1-5	Temperature Characteristics	-20		+20	ppm	-40°C to +85°C
1-6	Nominal Load Capacitance	16			pF	
1-7	Series Resistance			45	Ω	
1-8	Shunt Capacitance			7.0	pF	
1-9	Motion Capacitance				fF	
1-10	Motion Inductance				mH	
1-11	Q factor				K	
1-12	Spurious Response				dB	
1-13	Frequency Pull ability				ppm/pF	
1-14	C0/C1 Ratio					
1-15	Aging	-5		+5	ppm/year	
1-16	Insulation Resistance	500MΩ Min. @ DC100V				
1-17	Nominal Drive Level	10			μW	into 30Ω
1-18	Dependency Condition				μW	
1-19	Drive Level Dependency Resistance Max. Minus Min.				Ω	
1-20	Drive Level Dependency Frequency Max. Minus Min.				ppm	
1-21	Drive Level Dependency Resistance Max.				Ω	

■ CUSTOMER SPECIAL REQUIREMENT

2	
---	--

■ ENVIRONMENTAL

	Parameter	Reference Std.	Test Condition
3-1	Vibration Test	MIL-STD-883 2007 Condition A JESD22-B103 Condition 1	10~2000Hz, 1.52mm, 20g, each axis for 4 hrs
3-2	Thermal Shock	MIL-STD-883 1010 Condition B JESD22-A104 Condition B	-55°C, 125°C; soak time is 10 mins, with total 200 cycles
3-3	Mechanical Shock	MIL-STD-883 2002 Condition B JESD22-B104 Condition B	1500G, half-sine, 0.5ms, each axis for 3 times.

■ RECOMMENDED IR REFLOW PROFILE

- IR REFLOW PROFILE OF CERAMIC SMD PRODUCTS FOR Pb FREE PROCESS

TAITIEN ELECTRONICS CO., LTD.

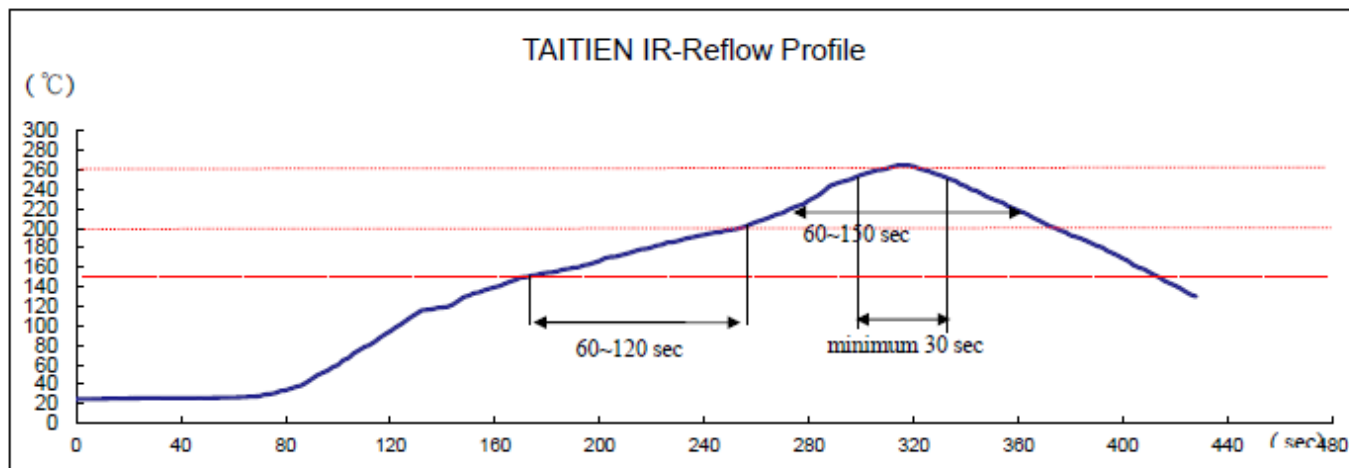

Reference Standard: JEDEC-STD 020

Test conditions: Pre-heating : 150°C to 200°C, 60~120secs.

Heating : 217°C, 60~150sec.

Peak temperature at least : 260°C, The time above 255 °C : minimum 30sec.

■ PRODUCT DIMENSIONS

➤ DIMENSIONS

Unit:mm

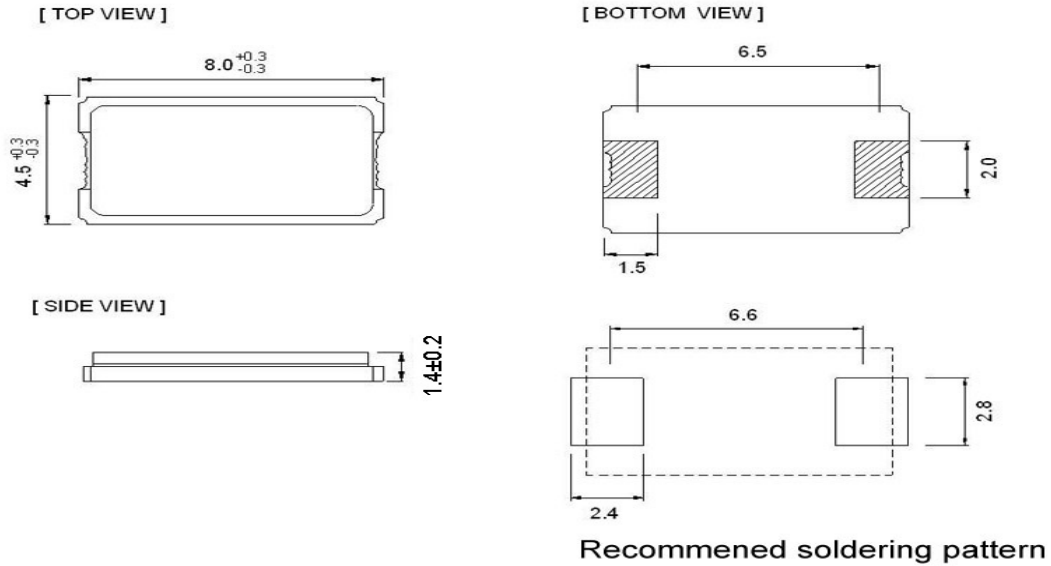

■ PRODUCT IDENTIFICATION (MARKING)

➤ PROCEDURE: LASER

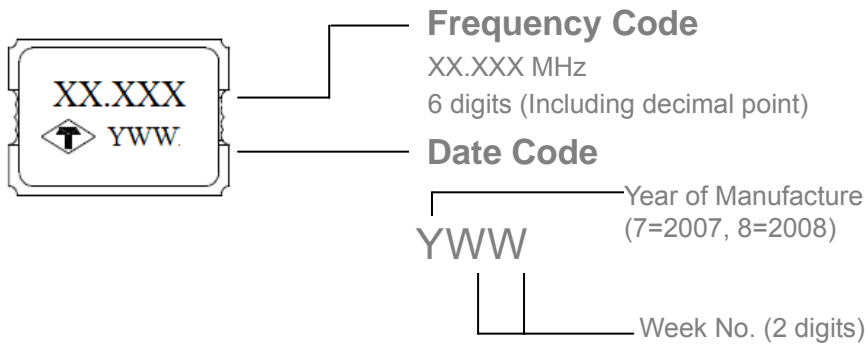

➤ FOR EXAMPLE:

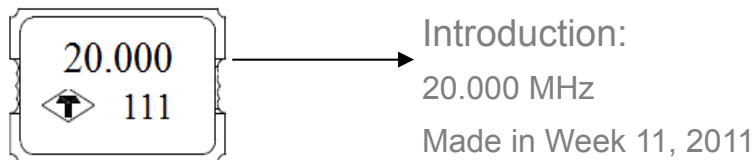

PACKAGE INFORMATION

TAPE (CARRIER) DIMENSIONS

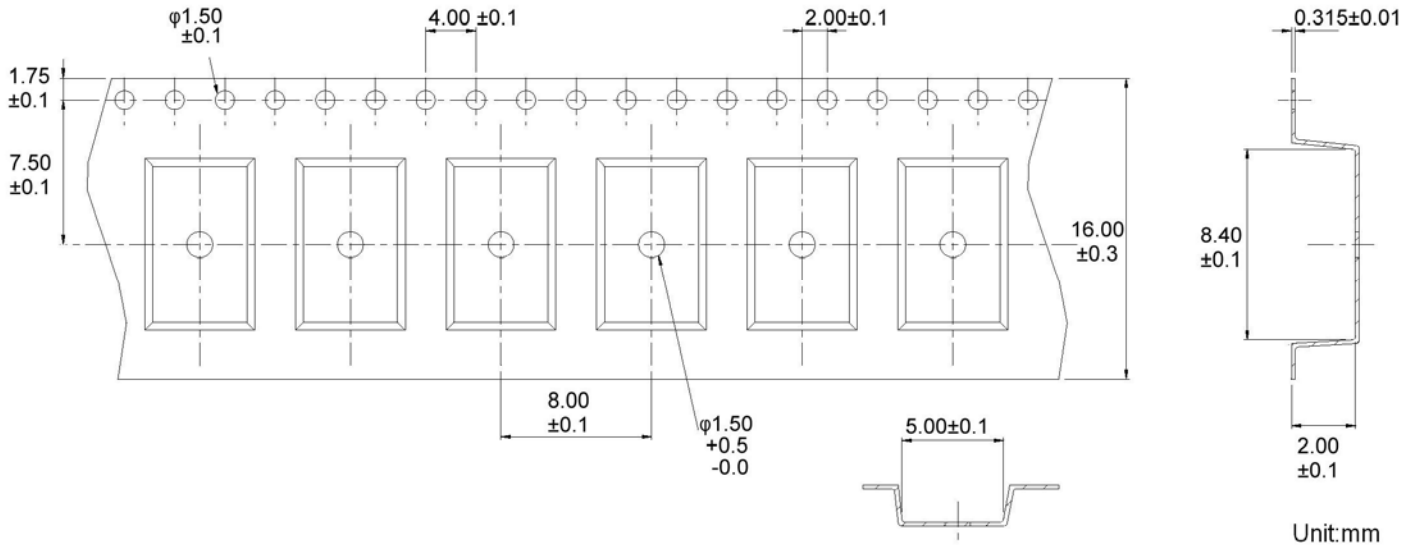

Unit:mm

THE DIRECTION OF PACKING

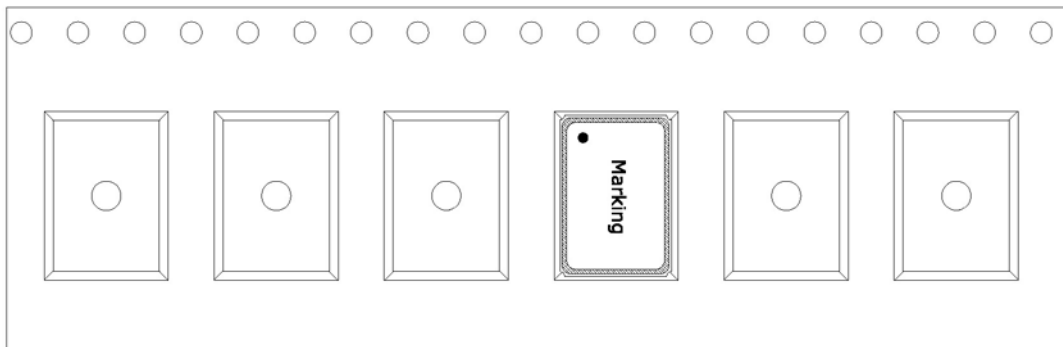

REEL DIMENSIONS

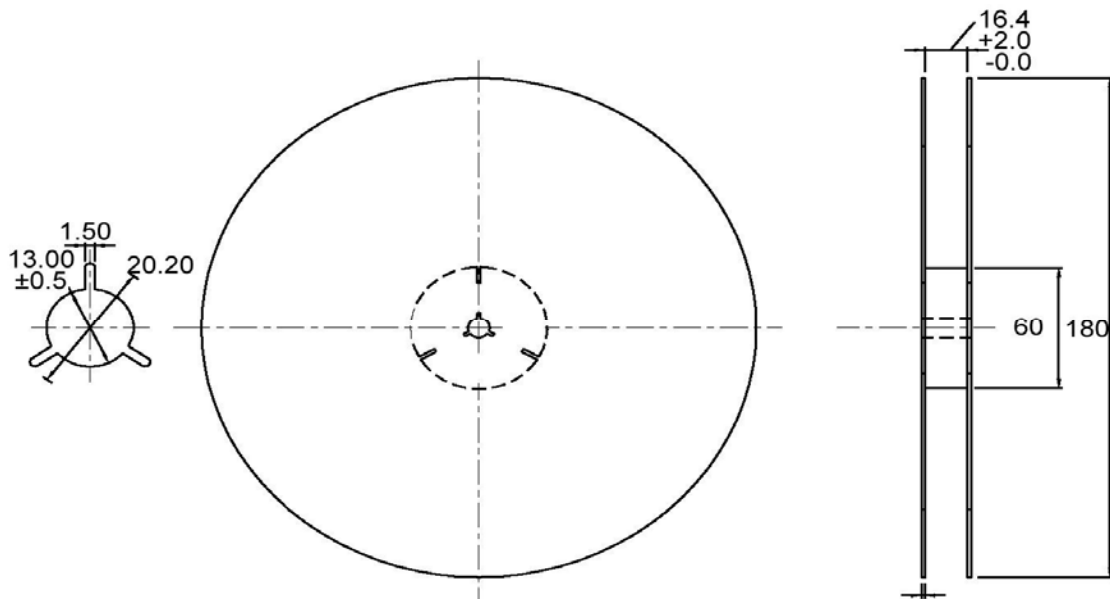

Unit:mm